

RESTRICTED



**BOMBARDIERS'
INFORMATION
FILE**

BIF

THIS COPY OF BIF BELONGS TO . . .

[Handwritten signature]
[REDACTED]
NAME RANK SERIAL NO. ORGANIZATION

IT CONTAINS THE REVISIONS LISTED BELOW

REVISION NO.	DATE OF REVISION	DATE FORM 248A CERTIFIED

AS YOU REVISE YOUR BIF WRITE REVISION NUMBERS AND DATES IN THE SPACES PROVIDED ABOVE

TABLE OF CONTENTS

IN accordance with the provisions of AAF Regulation 62-15, dated 24 November 1944, all AAF bombardiers in the United States will certify that they have read and that they understand all instructions and information contained in the Bombardiers' Information File. They will do so by signing in the space provided at the end of the Table of Contents.

Check with operations offices regularly to be sure you have all current amendments to BIF and Table of Contents. The Table will be revised quarterly and distributed on the same basis as the Bombardiers' Information File.

BOMBARDIERS' INFORMATION FILE

SUBJECT AND DATE	BIF No.	SUBJECT AND DATE	BIF No.
INTRODUCTION ★			
Table of Contents (Mar. 45)	Intro. 1	AAF Regulation 62-15	Intro. 5
How to Use BIF (Mar. 45)	Intro. 3	AAF Regulation 15-24	Intro. 7
SECTION ONE ★ General			
Crew Cooperation (Mar. 45)	1-1	Safeguarding Classified Material (Mar. 45)	1-5
Duties of Staff Bombardier (Mar. 45)	1-2	R/T Procedure (Mar. 45)	1-6
Bombardier's Kit (Mar. 45)	1-3	Films and Publications (Mar. 45)	1-7
Bombing Flight Record—Form 12C (Mar. 45)	1-4	Unsatisfactory Reports (Mar. 45)	1-8
SECTION TWO ★ Fundamentals of Bombing			
Bombing Problem (Mar. 45)	2-1	Bombing Analysis (Mar. 45)	2-4
Bombing Tables (Mar. 45)	2-2	Aids for Bombardiers (Mar. 45)	2-5
Bombing Errors (Mar. 45)	2-3		
SECTION THREE ★ Computers			
E-6B Computer (Mar. 45)	3-1	G-1 Computer (Mar. 45)	3-4
Automatic Bombing Computer (Mar. 45)	3-2	Time-of-Run Computations (Mar. 45)	3-5
Bombing Altitude Computations (Mar. 45)	3-3		
SECTION FOUR ★ Instrument Calibration and Navigation			
Free Air Temperature Gage (Mar. 45)	4-1	Astro-Compass (Mar. 45)	4-7
Pitot-Static System (Mar. 45)	4-2	Bombsight and Driftmeter Alignment (Mar. 45)	4-8
Airspeed Indicator (Mar. 45)	4-3	Pilotage Navigation (Mar. 45)	4-9
Altimeter (Mar. 45)	4-4	Dead Reckoning Navigation (Mar. 45)	4-10
Magnetic Compass (Mar. 45)	4-5	Radio Navigation Aids (Mar. 45)	4-11
Gyro-Stabilized Flux Gate Compass (Mar. 45)	4-6		
SECTION FIVE ★ C-1 Autopilot			
Nomenclature and Functioning (Mar. 45)	5-1	Directional Panel Turns (Mar. 45)	5-5
Preflight Procedure (Mar. 45)	5-2	Maladjustments and How to Correct Them (Mar. 45)	5-6
Engaging Procedure (Mar. 45)	5-3	Formation Stick (Mar. 45)	5-7
Flight Adjustments (Mar. 45)	5-4		

RESTRICTED

SUBJECT AND DATE BIF No. SUBJECT AND DATE BIF No.

SECTION SIX ★ M-Series Bombsight

Nomenclature and Operation (Mar. 45)	6-1	Cold and Hot Weather Operation (Mar.45)	6-5
Preflight and Post-Flight Procedures (Mar. 45)	6-2	Bombing with Defective Bombsight (Mar. 45)	6-6
Field Inspection and Care (Mar. 45)	6-3	Glide Bombing Attachment (Mar. 45)	6-7
Trouble Shooting (Mar. 45)	6-4	Modifications and Attachments (Mar. 45)	6-8

SECTION SEVEN ★ Armament

Bombs (Mar. 45)	7-1	B-24 Bomb Racks and Controls (Mar. 45)	7-6
Fuzes (Mar. 45)	7-2	B-29 Bomb Racks and Controls (Mar. 45)	7-7
Fuze Installation (Mar. 45)	7-3	A-26 Bomb Racks and Controls (Mar. 45)	7-8
Bomb Racks and Controls (Mar. 45)	7-4	Caliber .50 Machine Gun (Mar. 45)	7-9
Preflight Procedure (Mar. 45)	7-5	Gun Turrets (Mar. 45)	7-10

SECTION EIGHT ★ Combat Bombing

Bombardier's Checklist (Mar. 45)	8-1	High Altitude Bombing (Mar. 45)	8-7
Briefing and Interrogation (Mar. 45)	8-2	Medium Altitude Bombing (Mar. 45)	8-8
Target Identification (Mar. 45)	8-3	Minimum Altitude Bombing (Mar. 45)	8-9
Train Bombing (Mar. 45)	8-4	Tactical Variations by Theater (Mar. 45)	8-10
Flak Analysis and Evasive Action (Mar. 45)	8-5	Maneuvering Targets (Mar. 45)	8-11
Formation Bombing (Mar. 45)	8-6	Camera Bombing (Mar. 45)	8-12
		Bombing Through Overcast (Mar. 45)	8-13

SECTION NINE ★ Emergencies and Precautions

First Aid in Flight (Mar. 45)	9-1	Fire Fighting (Mar. 45)	9-12
First-Aid Kits (Mar. 45)	9-2	Parachutes (Mar. 45)	9-13
Physical Fitness (Mar. 45)	9-3	Life Preserver Vests (Mar. 45)	9-14
Effects of High Altitude (Mar. 45)	9-4	Swimming Through Fire (Mar. 45)	9-15
Oxygen Equipment (Mar. 45)	9-5	Ditching (Mar. 45)	9-16
Portable Oxygen Equipment (Mar. 45)	9-6	Life Raft Kits and Discipline (Mar. 45)	9-17
Pressure Breathing (Mar. 45)	9-7	One-Man Life Raft (Mar. 45)	9-18
Oxygen Emergencies (Mar. 45)	9-8	Signal Devices (Mar. 45)	9-19
Dangerous Gases (Mar. 45)	9-9	Vest Type Emergency Kit (Mar. 45)	9-20
Flak Suits (Mar. 45)	9-10	Climate and Health (Mar. 45)	9-21
Vision at Night (Mar. 45)	9-11		

I CERTIFY THAT I HAVE READ AND UNDERSTAND ALL SUBJECTS IN THE BOMBARDIERS' INFORMATION FILE LISTED IN FORM 24B, DATED MARCH, 1945

SIGNED _____

RANK _____

ORGANIZATION _____

DATE _____

When you receive your new Form 24B, dated June, 1945, remove this form, sign it, and give it to your Operations Officer to put in your Form 5 file.

HOW TO USE BIF

Your BIF Responsibility

When you receive BIF revisions you are required by AAF Regulations 62-15 and 15-24 to do the following:

1. Sign the receipt portion of Form 24BA (which is always enclosed as the first sheet of every revision). Hand this receipt at once to the operations office where you receive the revision.

2. Read the directions on the envelope which contains the revision.

3. **Remove from your BIF and destroy** the pages which are listed on the envelope. Don't try to short-cut and place the revision pages in at the same time you remove the replaced pages. You are sure to make mistakes. Do it one step at a time. Go clear through your book and take **all** pages out that are listed on the envelope. **This is vital.**

4. Read and study the revision sheets until you understand them.

5. Place the revision sheets in **their proper place** in your copy of BIF.

6. When you have done all of the above, **and not until you have done it all properly**, sign the compliance section of Form 24BA and return it to your Operations Officer so that it may be placed in your Form 5 file.

You have 30 days (by AAF Regulation 15-24) in which to do all of the above. If you have neglected any of the steps listed you have violated regulations and are subject to disciplinary action.

The duties outlined here require perhaps 2 hours a month. If you shirk or neglect these duties your BIF cannot be useful to you. It must be currently correct or you cannot add new revisions properly.

Bombardiers' Information File is your book. It was designed to save you many hours of work. If it were not for BIF, you would have to search and read through thousands of pages of War Department, AAF, and miscellaneous publications to get the information which you have to have to keep up-to-date with your duties and responsibilities.

General

The Bombardiers' Information File is a manual of instructions and information of a general nature with which all AAF bombardiers in continental United States are required to comply, in accordance with the provisions of AAF Regulation 62-15.

BIF is designed to keep you informed promptly and conveniently of developments affecting techniques, instruments, and equipment. Check frequently to be sure you have read and understand the information it contains. BIF does not attempt, however, to provide specific engineering, maintenance, and supply information contained in T.O.'s.

What Page Numbers Mean

Each page in BIF is designated by 3 numbers. The **first number** indicates the section. For example, 1, which is General. The **second number** refers you to the subject. For example, 1-6, R/T Procedure. The **third number** lists the page. Thus, the fourth page of R/T Procedure is marked 1-6-4.

Revisions

BIF will be revised from time to time as new information becomes available. These revisions will be issued as properly numbered pages to correspond to the present BIF numbering system. You will put the revised pages in their proper places in your copy of BIF.

To make the process as simple as possible you will receive revisions in an envelope upon which is printed a list of the pages you are to remove from your copy of BIF and replace with revised pages.

Revised pages will bear a new date line in the upper right hand corner thus: REVISED June, 1945. If the page is new and does not replace an old one it will bear a line thus: ADDED June, 1945.

Often a whole subject will be revised completely and the revised pages may number more or less than the pages they replace. In such a case all the pages will merely bear the REVISED notation, with the date. So don't be confused if you have more or fewer pages than you have removed.

To Comply with Revisions

When you receive a set of revision sheets from your operations office, you will find in the envelope a temporary certificate of compliance (Form 24BA).

Before you sign it to certify that you have read and understand all the revisions, be sure you have read and have complied with each item to which you are certifying.

You will find that often only minor changes have been made on some pages. There is no special indication to show what sentences or paragraphs have been revised. It is felt that you should re-read the whole page in order to get the context of the old material in relation to the new.

Distribution of Revisions

Revisions are distributed to individual bombardiers by the Base Operations Officer, who receives revisions automatically from the File publisher.

If any Operations Officer does not receive the correct number of revisions (plus a 10% overage) he will communicate at once with

Office of Flying Safety, Information Files Branch,
Buhl Building, Detroit 26, Michigan
stating number of revisions required at his station. He will also send letter request to the above for any copies he may need of the complete File.

Operations Officers will also report promptly on the activation or deactivation of any station.

Table of Contents (Form 24B)

Every 3 months you will receive a new Table of Contents in the envelope with the latest revisions. In order that you may identify it and be sure that you have the current table in your BIF, the following color key is used:

June: Gray	December: Yellow
September: Blue	March: Red

Check your copy of BIF against the Table of Contents regularly.

Subjects preceded by an asterisk (*) have material revised or new since the last Table of Contents.

After the first revision you will find that all the pages of any one subject do not bear the same date. But the date following the subject listing in the Table of Contents is the latest revision date for any of the pages included in that subject.

Don't Destroy Table of Contents

When you replace the Table of Contents with a new one, **don't destroy the old one.** Sign it to show that you have read and understand all the subject

matter it lists. Then turn it over to your Operations Officer to be placed in your Form 5 file.

Operations Officers' Responsibilities

1. Each Operations Officer is responsible that every bombardier attached to his base receives a copy of BIF and all revisions.

2. That every bombardier on his base signs a compliance form certifying that he has read and understands all material contained in BIF and revisions.

3. That the compliance certificates (Form 24BA and Form 24B) are placed in the Form 5 files of the individuals concerned.

When bombardiers turn in their Forms 24B at the end of the three-months period for which the forms are the current tables of contents for BIF, the Operations Officer will see that previously dated Forms 24B and 24BA in the Form 5 files are removed and destroyed.



WANTED: Your Criticisms of BIF

May we call your attention to AAF Regulation 62-15, which directs all AAF establishments to submit, to the address given below, items they desire to have included. This also means any criticism of material already in BIF—corrections, questions of interpretation, and mistakes.

Our aim is to keep BIF accurate, current, and fully useful. If you can help us do that, we will appreciate it. Write direct to:

OFFICE OF FLYING SAFETY
Information Files Branch, Buhl Bldg.,
Detroit 26, Michigan

AAF REGULATION)
 NO. 62-15)
 EXTRACT)

HEADQUARTERS, ARMY AIR FORCES
 WASHINGTON, 24 NOVEMBER 1944

FLYING SAFETY

Information Files

(This Regulation supersedes AAF Regulations 62-15, 28 February 1944, and 62-15A, 1 May 1944.)

1. **General.** To promote safe flying and operational efficiency, AAF pilots, navigators, bombardiers, flight engineers, flight surgeons, aviation medical examiners, and airborne radio operators who are on flying status must be familiar with many items of a general nature, with the results of current research, and with other instructions and information found in a variety of War Department, AAF, and other pertinent publications which are not always readily available to them. These items will be selected, organized, and presented in simple, non-technical form in loose-leaf books, to be designated as follows:

* * * * *

c. For bombardiers: The "Bombardiers' Information File" (BIF).

* * * * *

2. **Publication of PIF, NIF, and BIF.** The Office of Flying Safety will be responsible for the selection of items, the coordination of the material, the form and treatment of the subject material, the proper illustration of the text, and the publication of the Files. That office will be responsible for the publication of necessary revisions. It is authorized to deal directly with all AAF organizations and establishments in gathering and coordinating instructions and information for the Files. All AAF establishments will submit items which they desire to have included in the Files directly to Office of Flying Safety, Information Files Branch, Buhl Building, Detroit 26, Michigan.

3. * * * * *

4. **Table of Contents.** A table of contents, listing, numbering, and dating all current subjects, will be published for each File. Each table of contents will be revised every three months. The use of the table of contents is outlined in AAF Regulation 15-24.

* * * * *

5. **Distribution in Continental United States.** These Information Files and revisions thereto will be distributed by the Chief, Office of Flying Safety on the following basis:

* * * * *

c. BIF: Through base operations officers, one copy to each AAF bombardier in the domestic area, one copy to each cadet in AAF Bombardiers' School. Two copies to each base operations office, group, and squadron. Copies as required to the regularly established files of AAF organizations and establishments. Copies to AAF schools and training establishments as necessary for the training program, and such copies as the Chief, Safety Education Division, Office of Flying Safety, will determine as necessary for the accomplishment of his basic directive.

* * * * *

6. **Distribution in Overseas Theaters.** If commanding officers in overseas theaters and "alerted" areas so direct, PIF, NIF, BIF, ROIF, and revisions thereto will be procured by requisition to the Director, Air Technical Service Command, Wright Field, Dayton, Ohio, through Air Technical Service Command distribution centers located in the theaters concerned.

7. **Compliance.** Commanding officers will be responsible that personnel specified in paragraph 5 certify that they have read and understand all instructions and information contained in their respective Files; and that they place the revision sheets issued to them in their personal copies of the Files so that their Files are currently correct. Compliance with this directive will be recorded as follows:

* * * * *

c. For bombardiers: Form 24B (the BIF table of contents) will be signed and used as a permanent record of compliance. When BIF and revisions thereto are distributed, they will be accompanied by compliance forms (AAF Form 24BA), which will provide temporary record of compliance. The use of AAF Forms 24B and 24BA is set forth in AAF Regulation 15-24.

* * * * *

e. For all other personnel authorized to receive PIF, NIF, BIF, or ROIF as set forth in paragraph 5 and for whom no Form 5 files are maintained, the record of compliance will be as directed by commanding officers.

8. **Retention of Permanent Forms.** Commanding officers will be responsible that permanent forms referred to in paragraph 7 are retained for record as directed in AAF Regulation 15-24.

9. * * * * *

10. **Activities Exempt from These Provisions.** AAF activities operating in overseas theaters and AAF activities operating in domestic areas under "alert" orders will be exempt from the provisions outlined herein to the extent determined by the commanding officer concerned.

11. **Definitions:**

* * * * *

c. The term "bombardier" will be construed to mean any individual who holds a currently effective military aeronautical rating of aircraft observer (bombardier) or aircraft observer (navigator-bombardier).

* * * * *

By command of General ARNOLD:

OFFICIAL SEAL

HQ AAF

BARNEY M. GILES

Lieutenant General, United States Army
Deputy Commander, Army Air Forces and
Chief of Air Staff

AAF REGULATION)
 NO. 15-24)
 EXTRACT)

HEADQUARTERS, ARMY AIR FORCES
 WASHINGTON, 23 NOVEMBER 1944

BLANK FORMS

AAF Form 24 —PIF Table of Contents
 AAF Form 24A —Temporary Compliance Certificate for PIF
 AAF Form 24N —NIF Table of Contents
 AAF Form 24NA—Temporary Compliance Certificate for NIF
 AAF Form 24B —BIF Table of Contents
 AAF Form 24BA—Temporary Compliance Certificate for BIF
 AAF Form 24R —ROIF Table of Contents
 AAF Form 24RA—Temporary Compliance Certificate for ROIF

(This Regulation supersedes AAF Reg. 15-24, 28 Feb. 1944, and AAF Reg. 15-24A, 2 Aug. 1944.)

TABLE OF CONTENTS OF INFORMATION FILES

1. * * * * *
 AAF Form 24B is the table of contents for the Bombardiers' Information File.
 * * * * *

Each has two uses:

- As a part of the Information File for which it is the table of contents for a three-month period (until it is replaced by a revised current table of contents). Each will list, date, and number all current subjects in its pertinent Information File. An asterisk (*) prefixing any subject will indicate that the subject has been revised or added since the previous table of contents was issued.
- As a compliance certificate for its pertinent Information File: Personnel specified in AAF Regulation 62-15 as being required to comply with pertinent information files and for whom a Form 5 file is maintained will sign the Form 24, 24N, 24B, or 24R (whichever applies). When a new table of contents is issued, it will replace the one in the Information File, and the replaced Form (24, 24N, 24B, or 24R), properly signed, will be placed in the Form 5 file of the individual concerned, where it will remain as a record of compliance until the next issued Form (24, 24N, 24B, or 24R) replaces it. Compliance records for personnel authorized to receive pertinent Information Files and for whom Form 5 files are not maintained will be kept as directed by commanding officers.

2. **Publication.** Under the authority contained in AAF Regulation 62-15, the Chief, Office of Flying Safety will revise and publish AAF Form 24, 24N, 24B, and 24R every three months. In order to facilitate identification of the date of issue, there will be a color band along one border of the respective forms as follows:

* * * * *
 Form 24B Issue of 1 September (any year)—Blue
 Issue of 1 December (any year)—Yellow
 Issue of 1 March (any year)—Red
 Issue of 1 June (any year)—Gray
 * * * * *

3. **Distribution.** AAF Form 24, 24N, 24B, or 24R will be distributed by the Chief, Office of Flying Safety through base operations officers:

- As a part of every complete volume of the Information File for which it is the table of contents.
- As one sheet of revisions to the Information File to which it belongs, issued as follows:

* * * * *
 Form 24B: BIF revisions dated 1 September, 1 December, 1 March, and 1 June.
 * * * * *

- Upon letter request to: Office of Flying Safety, Information Files Branch
 Buhl Building, Detroit 26, Michigan

TEMPORARY CERTIFICATES OF COMPLIANCE

4. Since Forms 24, 24N, 24B, and 24R are retained in their respective Information Files for the three-month period for which they are the current tables of contents, it is necessary to use temporary certificates of compliance for revisions which may be issued in the interim. Such temporary certificates will be issued as follows:

* * * * *

Form 24BA for Bombardiers' Information File

* * * * *

Each such temporary certificate of compliance form consists of two sections; a small detachable bottom section, the use of which is described in subparagraph a. below, and a main upper section, the use of which is described in subparagraph b. below:

- a. The detachable section at the bottom of each form is provided as a receipt for revision sheets (or for the complete volume of the pertinent Information File issued to any individual entitled to it). The individual receiving any Information File material will indicate by signature thereon that he has received it. Operations officers will hold such receipts for their records until the compliance (main upper section of Form 24A, 24NA, 24BA, or 24RA) is received. Whenever Information File material is issued to any individual entitled to it at any station other than his home base, his receipt (the lower detachable section) will be forwarded by the issuing agency to the base operations officer of the recipient's home station.
- b. The main (upper) section of Forms 24A, 24NA, 24BA, and 24RA will list in red the revision number and the page numbers for which each is to serve as a temporary compliance certificate. When issued with the complete volume of the Information File, it will indicate that it applies to the complete volume of the pertinent Information File and indicate (in red) the revision numbers contained as an integral part of that edition of the Information File. An individual concerned will sign this portion of the form to certify that:
 - (1) He has read and understands the Information File material listed therein.
 - (2) He has **removed** from the Information File and **destroyed** all sheets that specific instructions printed on the envelope which contains the Information File material direct him to remove and destroy.
 - (3) He has placed each revision sheet listed in the compliance certificate in its proper place in the Information File.
 When the individual concerned has complied with (1), (2), and (3) above, (**and not before**), he will sign the compliance certificate (the upper section of Form 24A, 24NA, 24BA, or 24RA) and return it to the base operations officer at his home station.

5. Operations officers will be responsible that the properly executed compliance certificate (upper section of Forms 24A, 24NA, 24BA, or 24RA) is returned within a reasonable time (but in no case longer than 30 days after receipt) and, in the case of personnel for whom Form 5 files are maintained, placed in the Form 5 file of the individual concerned. It will remain there until the individual has executed the next dated table of contents (Form 24, 24N, 24B, or 24R, whichever applies) and turned it in, when all previously dated compliance certificates (Forms 24A, 24NA, 24BA, or 24RA) and the previous table of contents will be removed and destroyed. Compliance certificates for personnel for whom Form 5 files are not maintained will be retained for record as directed by commanding officers.

6. **Distribution.** AAF Forms 24A, 24NA, 24BA, and 24RA will be published by the Chief, Office of Flying Safety and distributed:

- a. Through operations officers, automatically inclosed with each set of revisions and each complete volume of any Information File.
- b. Upon letter request from operations officers to:

Office of Flying Safety, Information Files Branch
Buhl Building, Detroit 26, Michigan

7. **Destruction of Unused Forms:**

- a. Unused Forms 24, 24N, 24B, and 24R become obsolete and will be destroyed six months after the date of issue.
- b. Forms 24A, 24NA, 24BA, and 24RA held in excess of the material to which they apply will be destroyed.

By command of General ARNOLD:

OFFICIAL SEAL

HQ AAF

BARNEY M. GILES

Lieutenant General, United States Army
Deputy Commander, Army Air Forces and
Chief of Air Staff



SECTION

1

GENERAL . . .

The true test of a bombardier's ability is not merely what he knows about his own job. To become expert he must know enough about the jobs of everyone else in the airplane's crew to give them all possible help. It is obvious that the better they perform their tasks, the more efficiently he can do his.

Study should be a regular part of every bombardier's daily routine. Films and publications can teach him more about his many duties and show him how to correct his mistakes. From study, he can gain a broad understanding and appreciation of the staff bombardier's responsibilities, and thus cooperate more effectively with that officer in accomplishing successful missions. He can acquaint himself with new developments and achievements in bombardment.

Then, there are certain subjects every bombardier should know which do not have a direct relation to bombing. Yet they are essential to the proper functioning of an aircrew. They include such routine requirements as learning the proper use of the interphone equipment, perfecting a knowledge of radio and visual codes, and knowing how to safeguard classified material.

CREW COORDINATION



BOMBARDIER TO CREW

Cooperate with pilot: Explain to him the principles of the bombing problem. Emphasize importance of not changing altitude or airspeed radically during bombing run and of informing you before reaching bomb release point if altitude or airspeed is off. Tactfully assist him in preflight and adjustment of autopilot. Give him information on other aircraft ahead and below; talk him into formation. Report flak bursts and frontal fighter attacks.

Cooperate with navigator: Explain bombardiering to him so that he can assume role of bombardier in an emergency. Help in DR and pilotage navigation. Obtain drift and groundspeed from bombsight. Warn of approach of bad weather.

Cooperate with armament crew: Report accurately and promptly any malfunction of bombsight or other bombing equipment. Assist them in preflight of bomb racks and controls, and in loading and fuzing bombs. Assist in flight checking autopilot.

Cooperate with gunners: Assist in loading ammunition, and in preflight of guns and ammunition. Inform them of frontal fighter attacks at which they best can fire. When using remote control turrets, maintain closest coordination in transferring control.

Cooperate with radar operator: Explain the bombing problem to him; stress importance of supplying accurate data for bombing run. When visibility permits, give him check points and keep him informed of his accuracy. Work in closest coordination when bombing through overcast; notify him if visibility allows you to take over bombing run.

CREW TO BOMBARDIER

Pilot and copilot cooperate with you: They must coordinate closely in obtaining pre-set data, in making turn over IP, and in taking evasive action. They must adjust autopilot to obtain maximum performance for bombing. Pilot should not jockey airspeed or change altitude radically during bombing run. Before reaching bomb release point, they should notify you if altitude or airspeed is off. Pilot must make prompt but smooth, coordinated turns in following PDI.

Navigator cooperates with you: He should explain navigation to you, so that you can assume role of navigator in an emergency. He should check your computations of true airspeed, bombing altitude, wind, groundspeed, and drift. Navigator should check trail and disc speed found from bombing tables and set into bombsight. He helps to identify IP and target. On the bombing run navigator gives you the variations of airspeed and altitude and assists in making computations for offset bombing.

Armament crew cooperates with you: They assist in preflight of bomb racks and controls. They must load and fuze bombs carefully and accurately. Armament crew ground checks autopilot. They must maintain bombsight, bomb racks and controls, autopilot, guns and turrets with care and thoroughness and keep them in best possible condition.

Gunners cooperate with you: They assist in loading ammunition and in preflight of guns and ammunition. They report frontal attacks at which you best can fire. Gunners should report bomb rack malfunctions and bomb hit data.

Radar operator cooperates with you: He must work in close coordination with you on bombing run, especially when bombing through overcast. He should give you accurate information on check points, drift, bombing altitude, groundspeed, dropping angle.

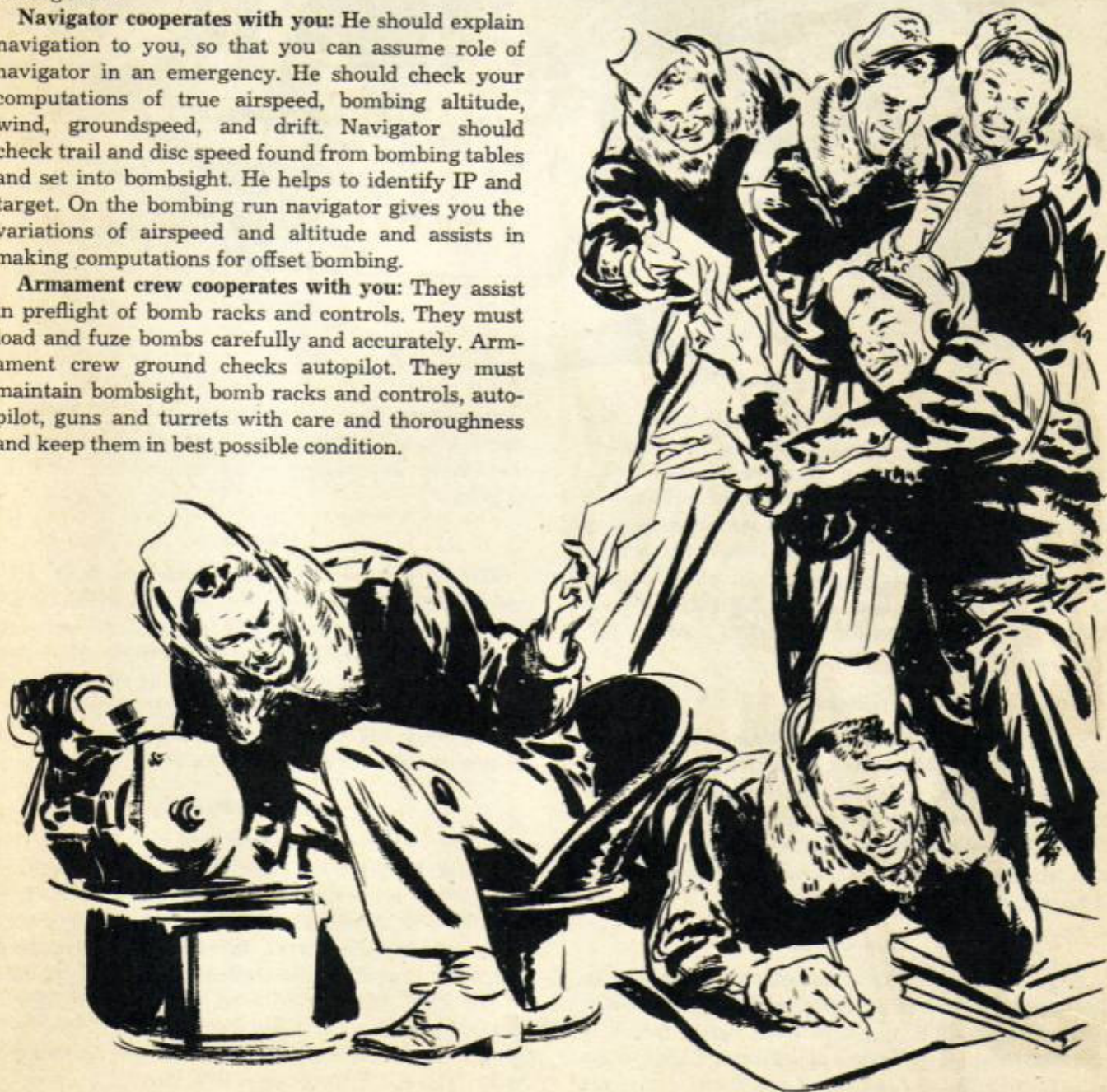

DUTIES OF STAFF BOMBARDIER

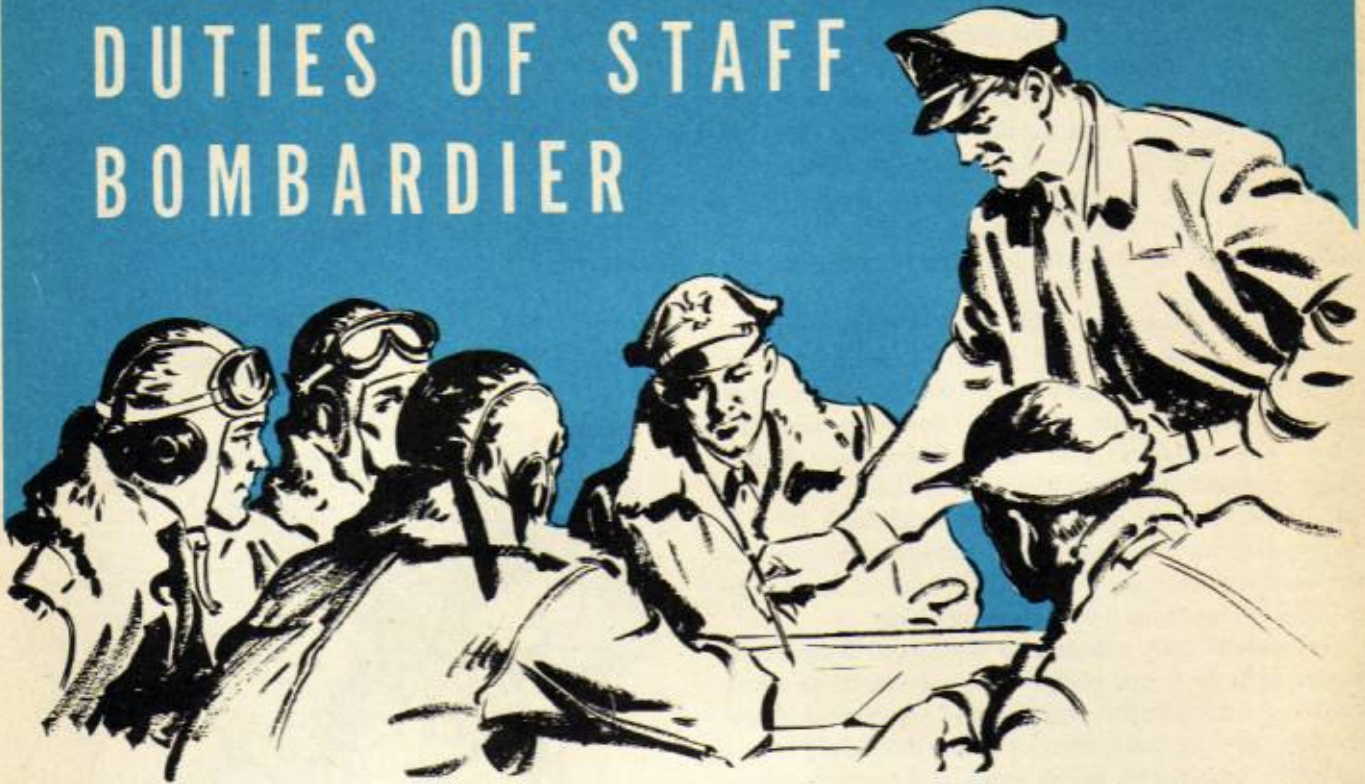

In most theaters there are air force, bomber command, and division bombardiers. In all theaters there are wing, group, and squadron bombardiers.

The staff bombardier, regardless of echelon, is adviser and bombing expert of the operations section within his unit. His sole function is to concern himself with bombing problems in all their details. Operations, training, and supply, together with the liaison which they demand constantly, are his primary interests.

Training

Supervises all bombardier training. Checks and analyzes results. Makes frequent checks on all new lead bombardiers, and on the more experienced ones, too. Arranges additional instruction where needed. Promptly provides bombardiers with new information about equipment and procedures. Checks to see if instruments are calibrated correctly.

Operational

Arranges regular crew discussions of tactical information. Fosters an offensive spirit in bombardiers, with an eye to obtaining constantly better results in combat. Frequently makes operational flights to obtain first hand information of conditions crews are

encountering. Advises commanding officer of technical aspects of bombing from bombardier's viewpoint. Assists in assembling target information and in briefing.

Liaison

Maintains liaison between armament staff, ordnance staff, and bombardiers. Maintains liaison between operations officers and bombardiers, between pilots and bombardiers. Coordinates flight schedules. Completes necessary URs on bombing equipment in cooperation with engineering officers. Provides liaison between his unit and the next higher echelon of command on matters pertaining solely to bombing.

Administrative

Keeps records of training and operations of individual bombardiers. Sees to it that failures of equipment are corrected. Acquaints himself thoroughly with all pertinent directives and makes sure they are complied with. Makes recommendations intended to produce more effective bombing results.

The staff bombardier who performs the above functions with tact, intelligence, energy, and efficiency is tremendously useful wherever bombing is done. The AAF needs more like him.



BOMBARDIER'S KIT

The bombardier's kit is a cloth case containing computers, tables, and pertinent working materials for use in maintaining bombing records and calculations. It is provided for every student and graduate bombardier through regular supply channels.

It includes: C-2, G-1, J-1, and E-6B computers; set

of dropping angle charts for use with E-6B computer; stop watch and wrist watch; pen-type flashlight; bombing flight record holder; tools; drafting pencils; eraser; dividers; Weems plotter; parallel rule; transparent triangles; bombing tables.

REFERENCE: Technical Order 00-30-35-2

BOMBING FLIGHT RECORD (AAF Form 12C)

You are responsible for filling out the greater part of AAF Form 12C, the Bombing Flight Record. A single copy of this form must be filled out for each training mission on which bombs are dropped.

Before takeoff you record on it all available data you will use in sighting and releasing bombs. **In flight** you enter on it data needed to determine corrections for airspeed and altimeter readings, and a detailed record of each bomb release. **After the mission** and after you have checked your form thoroughly, submit it as directed by local authority.

Fill out the Form 12C as **accurately and completely** as possible. **This is important.** The completed report makes it possible to analyze the results you have obtained. Although it is a temporary form, it is the source of information kept in permanent records, AAF Forms 12A and 12B.

How to Fill Out AAF Form 12C

(1) Give last name, first name, middle initial, grade, and commission (AC or AR).

(2) Provide same information about pilot. If two or more pilots flew airplane during mission, give names of all and note after each the number of releases each accounted for as pilot. Each bombardier will use separate form to record his releases.

(3), (4), (5), (6), (7) Self-evident.

(8) Enter target name and number, or both.

(a) Show whether target was fixed, moving, or maneuvering. If moving, give direction and speed. If maneuvering, describe type and state nature and speed of maneuvers which occurred during sighting, release, and ATF.

(b) Show whether target was point or area. If area, give dimensions and direction of long axis. Surface vessels or silhouettes of such are, for aiming or scoring, considered point targets.

(c) If bombing was done at night, state nature of target and means of illumination.

(d) If more than one target was used on mission reported on single form, indicate by number which releases were made at each target.

(9) Use same number as that of operations order assigning mission. Show whether mission was instructional, qualification, combat, service test, demonstration, or other type; whether practice or record; whether day or night. If "service test," state what equipment was being tested.

(10), (11), (12) Self-evident.

(13) Indicate hour when calculation is made and

data used. Fill in all available forecasts. Record known elevation of target above sea level in advance in order that you may calculate altitude above target. Use teletype code to record direction and speed of winds at altitudes known. For example, 22417 indicates wind at 2000 feet to be from 240° at 17 mph.

(14) Enter temperature recordings corrected for airspeed compression error at every 1000 feet of altitude above ground.

(15) Enter altitude at which corresponding temperature was recorded.

(16) Plot points of impact from your estimate at time each is made.

Upon receiving triangulation data or photographs, unit bombing officer or statistical section **with colored pencil or ink** will make final plotting of points of impact.

(17) List in sequence numbers assigned to successive approaches.

(18) List in sequence. Numbers simply identify releases with conditions pertaining to them.

(19) In case release was made by bombing formation, total number of bombs dropped will be entered on Form 12C of lead bombardier. Each other bombardier in formation will enter number actually dropped from his own airplane on that approach. They will be recorded as bombs dropped but will not be scored on his accumulative circular error.

(20), (21) Self-evident.

(22) Indicate by check mark if time of bombing approach is over 2 minutes. If 2 minutes or less, enter interval of time between beginning steady flight for synchronization on target and bomb release.

(23) Self-evident.

(24) Unit bombing officer or statistical section will fill in these columns from most reliable source available, usually triangulations by ground observers or photographs. In case of formation bombing, he will enter range, deflection, and circular error of MPI of formation pattern.

(25) Enter disc speed read from tachometer after final adjustments prior to release.

(26) Self-evident.

(27) Enter time of bomb impact on 24 hour basis. For example: 1330:45.

(28) Enter amount and direction.

(29), (30) Self-evident.

(31), (32), (33), (34) Check appropriate square. For (33), consider good visibility to be 10 miles or more; poor, 5 miles or less.

SAFEGUARDING CLASSIFIED MATERIAL

Military information and devices are classified as **top secret, secret, confidential, or restricted**. All classified material is clearly marked with its classification. If it is not so marked, it is unclassified. Treat all classified material as follows:

Top Secret

May be read or handled only by specifically designated persons. No one may have access to it merely because of his rank or office. Special procedures for handling top secret material are covered by letter instructions to the people concerned.

Secret

Only persons directly concerned should read it. It should be discussed only with those who may read it. It must be kept in a 3-combination safe when not in use. It must be mailed in two envelopes, an inner envelope addressed properly and marked or stamped **Secret**; an outer envelope addressed properly, **but with no marking to indicate its classification. Send it by registered mail.**

To destroy secret or confidential material, burn it, or use an approved shredding machine. Until you can do one or the other, tear it in small pieces and safeguard it as you would the original material.

Confidential

May be read only by persons in the military establishment and by civilians whose duties require that they read it. It may be discussed with those authorized to read it, **but never over the telephone.** Mail and guard it the same as secret material.

Restricted

May be read by, and discussed with anyone whose loyalty is unquestioned. It is never to be released for publication, or discussed with the general public.

It is to be kept in a guarded area, behind locked doors, or in a safe.

Mail by first class mail unmarked.

To destroy, tear up the material before throwing it into a wastebasket.

Inspection

At every Headquarters an inspection will be made each day immediately before closing to insure that classified material is properly taken care of.

Classified Equipment

The regulations for safeguarding classified equipment are, so far as practicable, the same as those for written matter. In general the procedure for handling secret and confidential equipment is as follows:

When you land at an Army Air Field, either post an armed guard or remove the equipment and place it in a locked safe or vault.

When you land at any other field, be sure that an armed guard is continuously assigned to your airplane. **Locking the airplane is not a substitute for a guard.**

When you are forced down in or near enemy-held territory, destroy all secret and confidential equipment. If detonators are installed, use them. If not, destroy the equipment manually. Make certain that the essential parts of the equipment are destroyed beyond recognition.

Remember: You are directly responsible for the classified material in your possession. You may at any time become responsible for such material normally in the hands of others. You must **understand** these classifications in order to know what your responsibilities are in any given case. You must **observe** security regulations at all times or you will endanger yourself, your crew, and your mission.

REFERENCE: Army Regulation 380-5

RIT PROCEDURE

Under normal circumstances you are concerned chiefly with the interphone portion of the airplane's radio system, through which you receive data from other crew members or give instructions to them. However, to do this efficiently and to meet possible emergencies you must know the basic radio equipment of the airplane and how to use it properly.

JACKBOX

You connect your microphone and headset to the airplane's radio system by means of the jackbox at your duty station. The knob on the jackbox marked INCREASE OUTPUT controls the volume of your reception. The switch in the center of the jackbox may be turned to any one of 5 positions.

Compass

The COMP position lets you listen to the radio compass receiver. You cannot transmit with the switch in this position.

VHF Liaison

With the switch at VHF LIAISON you are plugged into the airplane's long range radio and can both transmit and receive. To transmit, press the microphone button. To receive, release it.

Command

With the jackbox switch at COMMAND, you are plugged into the command set, a short range radio used chiefly in plane to plane or plane to ground communication, for sending and receiving operational instructions. It is also used to receive radio navigational aids. The command set is used mainly to communicate by voice but it is also equipped to transmit code. Code carries better than voice in bad weather and can be received over greater distances.

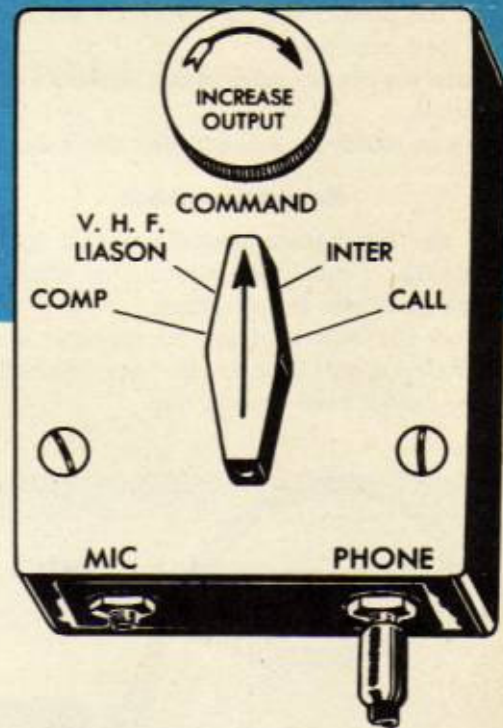

Interphone

Use INTER when you want to communicate with any other crew member whose jackbox is also on the interphone position. Press the microphone button to talk. Release it to listen. You cannot be heard outside the airplane.

Call

On CALL your voice can be heard at every other duty station regardless of the setting of the jackboxes. You will not be heard outside the airplane. Hold the switch at CALL and at the same time press the microphone button. After you have called the crew member you want, immediately return the switch to INTER while you wait for his answer. **CALL blocks out all other reception.** To answer you, he switches to INTER and proceeds.

MICROPHONES

Throat Microphone

Buckle your throat microphone around your neck so that it fits firmly with the rubber contact buttons placed one on each side of your Adam's apple and slightly above it.

Place the strap slightly higher than the microphone level to maintain this position.

Don't allow clothing to get between the buttons and your throat.

Place the positioning clip between the buttons to get the best results.

Be sure the proper sides of the buttons are against your throat.

Speak as loudly as you can, but don't shout.

Hand Microphone

Hold the hand microphone squarely in front of your mouth. Touch the mouthpiece slightly with your lips when you are speaking.

Depress the button of the microphone when you speak. Release it as soon as you have finished; otherwise you cannot hear anyone else.

PROCEDURE

Interphone

The following tips for radio telephone procedure apply equally to speaking on the interphone. Always speak clearly and concisely. **Always release the microphone button as soon as you finish talking.**

Unless your message is really urgent do not use the system while someone else is speaking. Operation is seriously impaired if more than one microphone button is depressed at a time. Also, more than one voice at a time creates confusion.

Always put your headset on as soon as you take your place in the airplane. Someone may need to get in touch with you.

Work out and use a regular procedure for interphone communication with the other crew members. Interphone procedure has not been generally standardized but you can use radio telephone terms.

Preface your remarks with "Bombardier to pilot," or whomever you are calling.

Pressing and releasing the microphone button produces a distinct click. Many crews use 2 clicks to acknowledge receipt of a message.



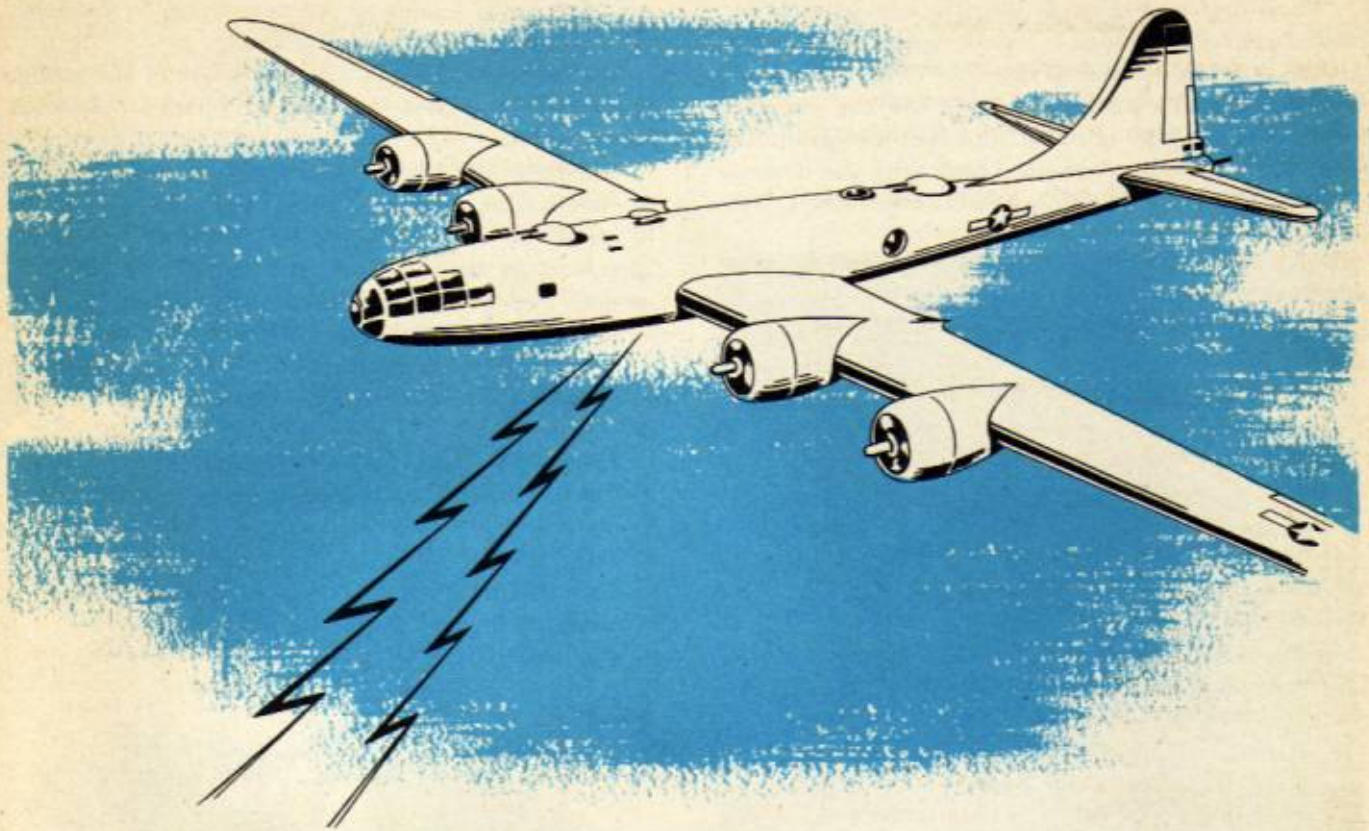

RADIO TELEPHONE

Here are some of the main points of standard procedure which **you must use** whenever you are speaking by radio telephone:

Transmit in a concise and businesslike manner. Make only necessary official transmissions.

Speak slowly. Pronounce each word and number distinctly.

Know your message. Group your words so that the idea is clear.

Don't hesitate. Don't say "uh" and "er."

Speak loudly enough to be heard above the surrounding noises, but don't shout.

Radio Telephone Terms

"Message for you" means "I wish to transmit a message to you."

"Send your message" means "I am ready for you to transmit."

"Acknowledge" means "Let me know that you have received and understood this message."

"Roger" means "Received your message."

"Wilco" means "Received your message and will comply."

"Say again" means "Repeat."

"I say again" means "I will repeat."

"Verify" means "Check coding and text with the originator and send correct version."

"That is correct" is self-explanatory.

"Wrong" means "What you have just said is incorrect. The correct version is —"

"Correction" means "An error has been made. The correct version is —"

"Break" means "I hereby indicate the separation of the text from other portions of the message."

"Over" means "My transmission is ended. I expect a reply."

"Out" means "End of message. No reply needed."

"Wait" means "I must pause for a few seconds."

"Wait. Out." means "I must pause for longer than a few seconds."

"Read back" means "Repeat all of this message back to me exactly as received."

Alphabet and Numbers

When it is necessary to identify any letter of the alphabet or spell a word in a radio telephone message, use the standard phonetic alphabet. When you transmit numbers by radio telephone use the standard pronunciation. The phonetic alphabet and pronunciation of numbers are printed here with the international radio code, which you also must know well.

LETTER	SPOKEN AS	CODE
A	Able	• -
B	Baker	- • • •
C	Charlie	- • - •
D	Dog	- • •
E	Easy	•
F	Fox	• • - •
G	George	- - •
H	How	• • • •
I	Item	• •
J	Jig	• - - -
K	King	- • -
L	Love	• - • •
M	Mike	- -
N	Nan	- •
O	Oboe	- - -
P	Peter	• • - •
Q	Queen	- - • -
R	Roger	• - •
S	Sugar	• • •
T	Tare	-
U	Uncle	• • -
V	Victor	• • • -
W	William	• - -
X	X-ray	- • • -
Y	Yoke	- • - •
Z	Zebra	- - • •

NUMERAL	SPOKEN AS	CODE
1	Wun	• - - - -
2	Too	• • - - -
3	Thuh-ree	• • • - -
4	Fo-wer	• • • • -
5	Fi-yiv	• • • • •
6	Six	- • • • •
7	Seven	- - • • •
8	Ate	- - - • •
9	Niner	- - - • •
0	Ze-ro	- - - - -

Radio Telephone Messages

Every radio telephone message must be composed of 3 parts: call, text, and ending.

Identify your call letters and those of the station you want to contact by using the phonetic alphabet. For example, "Able Baker. This is Victor Seven."

Conclude the text of your message with the time of origin. Use the word "Time," then the appropriate 4 numbers, and finally the key letter of the appropriate time zone. "Time, one three two zero, C" means that the preceding message was written for transmission at 1320 hours Central War Time.

Terminate all messages with "Over" or "Out."

A typical radio telephone message might run as follows:

Call "Able Baker. This is Victor Seven."

Text "Proceed as ordered. Time, one three two zero, C."

End "Over."

Call "Victor Seven. This is Able Baker."

Text "Wilco."

End "Out."

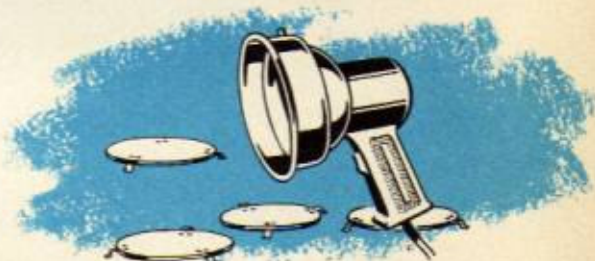

Visual Recognition

When radio equipment fails or is shot out, or when it is desirable to maintain radio silence, you frequently maintain limited communications with an Inter-Aircraft Control Lamp Assembly. This assembly, popularly called an Aldis lamp, is a trigger-operated hand light. It has 4 filters with which you can dim or color the light beam. The lamp plugs into the airplane's electrical system on a 10-foot cable.

You normally use the Aldis lamp to communicate between aircraft in formation or with ground crew men, aiming it with sights on its top. In combat areas it is used to challenge aircraft approaching landing strips, to check the identity of nearby aircraft in flight, and to identify surface vessels. The operator blinks challenges and responses to challenges in Morse code. Signals selected for both are chosen by the day or, if the enemy is likely to figure out the code, changed as frequently as several times a day.

FILMS AND PUBLICATIONS

More than 20 training films and 35 film strips of interest to bombardiers are now available. Subjects range from "Theory of Bombing" (TF 1-277) to "Target Identification, Part I" (Film Strip 1-626), and fall generally into three categories: principles, equipment, operations. The list of subjects undergoes constant revision as equipment becomes obsolete and operations are considered outmoded.

These visual aids are useful not only in the basic training of bombardiers but for refresher purposes in the field. Moreover, they help to familiarize other crew members with the bombardier's duties. In addition to training films and film strips on bombing subjects many titles dealing with allied subjects valuable in bombardier training can be obtained.

All subjects are listed in the Training Film and Film Strip Catalog, and frequently issued supplements, published by Training Aids Division, Headquarters Army Air Forces.

Any unit desiring training films and film strips must requisition them through channels from Training Aids Division, 1 Park Avenue, New York 16, N.Y. The unit should list them with catalog numbers and titles on AAF Form 104-B in quadruplicate, retaining master form and forwarding copies only.

There are also certain publications of value to bombardiers in addition to technical orders, War Department technical manuals, and field manuals. These less familiar publications can be obtained through channels from Training Aids Division, though in many cases the number available is limited. Their titles appear on a list of AAF Training Literature which TAD publishes and revises.

Among the titles of special interest to bombardiers are: "Bombing Sense" (Air Ministry Pamphlet 139); "Map Reading"; "Students' Manual, Bombing"; "Navigation for Bombardiers"; "Instrument Calibration for Bombardiers"; "Aircraft Armament for Bombardiers"; "Glide Bombing Attachment"; and "Allied Subjects for Bombardiers". Other subjects useful to all aircrew members include: "Ditching Dope" (AFM No. 5); "Weather for Aircrew Trainees" (AFM No. 6); "Survival—Jungle, Desert, Arctic, and Ocean"; and "Physical Fitness Handbook."

All technical manuals and field manuals are listed

in FM 21-6 and in War Department training circulars announcing changes in that listing. Technical Order No. 00-1 is an index of all technical orders. Both manuals and technical orders may be obtained from the appropriate Area Air Technical Service Command on requisition forms prescribed in AAF Regulation 5-9.

Technical Order Numbering System

Every technical order (T.O.) has a series of three numbers separated by dashes to identify it. For example, T.O. 00-35A-1.

The **first number** always has two digits. It corresponds to the AAF property classification number. For instance, if the first number in the T.O. designation is 05, the T.O. concerns instruments; if it is 02, it contains information about engines and engine maintenance parts. The only number that doesn't correspond to a property classification is 00, which is used for T.O.'s of a general nature.

The **second number** of the technical order's identification represents the airplane or engine model, or the sub-division of the general property class identified by the first number. For example, under 03, Aircraft Accessories, the breakdown begins like this: 03-1, General; 03-5, Electrical Equipment; 03-10, Fuel System; 03-15, Oil System.

Sometimes the second number still does not give enough identification for you to find the equipment you are looking for, and it is necessary to use a letter after the number. For instance, consider 03-10, Fuel Systems. If you are looking for carburetors, you will find they are further separated by using B after 10; thus, 03-10B.

The **third number** of the T.O. designation represents a further sub-division of a general property class. For example, whereas 05-35 designates Navigation Equipment, 05-35-9 specifies a T.O. relating to a particular type of navigation equipment, the E-6B computer. Other examples include: 05-35-21, Altitude Correction Computer, Type AN 5837-1; 05-35-23, Pre-set Dropping Angle Scales for E-6B computer; 05-35-32, Operation of True Airspeed Computer, Type AN 5836-1.

REFERENCE: Technical Order 00-5

UNSATISFACTORY REPORTS

WAR DEPARTMENT AAF Form No. 54 (Revised 2-15-45)		WAR DEPARTMENT ARMY AIR FORCES		LEAVE BLANK	
TO BE FILLED IN BY STATION		UNSATISFACTORY REPORT		A. S. C. SERIAL No.	REFER TO
STATION SERIAL No.	DATE SUBMITTED	(See AAF Reg. 15-54 for information on Proper Use of this Form)		CLASS	
806	3-15-45				
STATION 155 APO 559		ORGANIZATION 329th Bombardment Group (H)			
SUBJECT OF REPORT Property Class—Name 11-A Knob, Autopilot Clutch		Manufacturer Norden Co.		AAF Order or Shipping No.	
AIRCRAFT—Model & AAF Serial No. B-17G 44-9761		ENGINE—Model & AAF Serial No.		UNIT OR ACCESSORY—Type, Model and Serial No. Bombsight, M-9, 12786	
AIRCRAFT REPORTS ONLY LAST O. L. R.—Depot		Date		Flying Time Since	
ENGINE REPORTS ONLY LAST OVERHAUL—Depot		Hours Since		Total Flying Time	
PART Name Knob, Autopilot Clutch		No. Previous Failures		Inspector's No. or Identification	
Time in Use		Quantity Known Defective		To Overhaul Facility (INITIALS)	
Quantity on Hand 35		Quantity Known Defective 35		Disposition of (Explain Below.)	
Indicate by "X" Disposition of Exhibit		Photographed and Prints Enclosed <input checked="" type="checkbox"/>		Repaired and Returned to Service <input type="checkbox"/>	
		Held for Instructions <input type="checkbox"/>		Disposed of (Explain Below.) <input type="checkbox"/>	
		Sent Under Separate Cover <input type="checkbox"/>		To Overhaul Facility (INITIALS) <input type="checkbox"/>	
		Sent in Attached Package <input type="checkbox"/>			
EXPEDITE					
GIVE COMPLETE DETAILS, PROBABLE CAUSES AND RECOMMENDATIONS BELOW: (Use Only Applicable Spaces Above—Avoid Unnecessary Repetition)					
<p>Knob, Autopilot Clutch, unavoidably left partially engaged during bombing run, has caused improper operation of C-1 autopilot, thus partially engaged, PDI movement by this results in uncertain directional prevents proper course sync.</p> <p>Recommendation:</p>					
<p>3. Defects due to faulty material, workmanship, or inspection.</p> <p>4. Unsatisfactory maintenance or supply methods, systems, or forms.</p>					

Information concerning even the smallest failure may be of great value if reported to proper authorities in time. Everyone is encouraged to submit Unsatisfactory Reports whenever he sees an opportunity to contribute to greater efficiency by suggesting correction of faults.

As a bombardier, you are in close touch with both methods and machines. A great ground organization is behind the men who fly. But both flying and ground operations always can be improved. Unsatisfactory Reports are designed to speed improvements and to permit the individual to present a maintenance problem and his suggested correction, through channels.

Unsatisfactory Reports usually fall into these general classes:

1. Failure of equipment.
2. Unsatisfactory design.

How to Prepare a U.R.

AAF Form No. 54, obtainable from the Engineering Officer, is used for Unsatisfactory Reports.

Each report must be a complete description of an individual case. It must explain the unsatisfactory condition, including all pertinent information, to enable investigation and correction of the trouble reported without the need for further requests for information. See AAF Regulation 15-54 for details about how to file different types of U.R.'s.

Coordination

All Unsatisfactory Reports originating at a station are routed through the Engineering Officer, who investigates and enters his endorsement. He sends the U.R. to the station Commanding Officer. It is then sent to Commanding General, Air Technical Service Command, Patterson Field, Fairfield, Ohio.

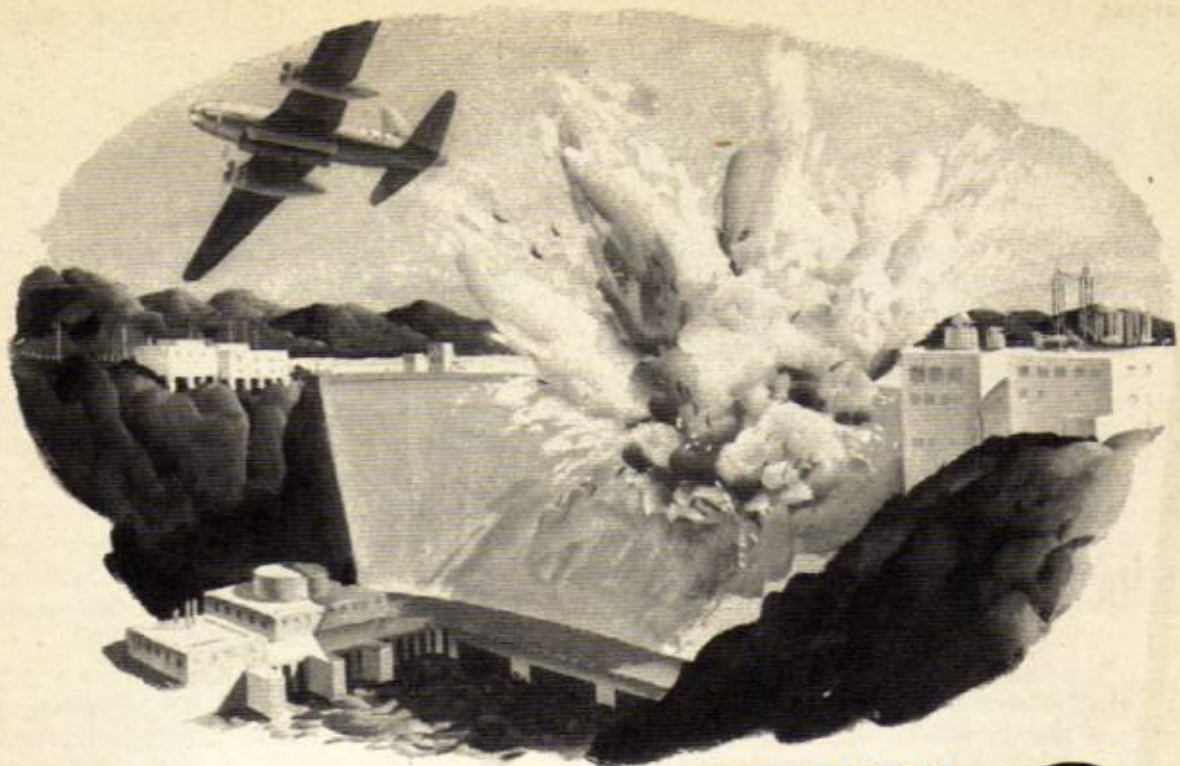

SECTION

2

FUNDAMENTALS OF BOMBING...

In order to have your bomb hit the target, you must locate the proper point in space from which to release it. Your bombsight finds this point and automatically releases the bomb, provided you put the correct data into it and operate it properly. A thorough knowledge of the bombing problem enables you to understand what data you must set into the bombsight, how to set it in, and how the bombsight uses it to solve the bombing problem.

Bombing errors can be reduced to a minimum and in many cases can be eliminated. Whenever your bomb misses the target, there is a definite cause for it. Only by learning the cause can you avoid repeating it. When you thoroughly understand what causes bombing errors, you can sense and correct them before your bomb is released. Learn as much as you possibly can from every bomb you drop.

Lack of experience may cause you to miss the target occasionally but there is no excuse for missing it because you failed to use your bombing tables correctly. You should derive all the benefit they can provide. Know what's in them and use them accurately.

Learn reliable short cuts and rules of thumb. You don't need to be a mathematical genius to understand and use the basic bombing equations.

BOMBING PROBLEM

The moment a bomb is released from an airplane it encounters several forces. These forces are: gravity, true airspeed, air resistance, and wind. The combined effect of these forces determines the path (trajectory) that the bomb follows and where it hits.

Gravity pulls the bomb toward the earth at a continually increasing speed. It exerts the same force on all bombs, whatever their size, shape, or weight.

Since the bomb is part of the airplane up to the instant of release, it leaves it with the forward speed of the airplane. This forward speed of airplane and bomb relative to air is **true airspeed (TAS)**.

Trail

Air resists the bomb in its flight and acts against the forces of gravity and TAS. This resistance keeps the bomb in flight longer and decreases its forward speed through the air. Thus it lags behind the airplane. The horizontal distance that it lags is its **trail**. Trail, consequently, is the horizontal distance measured on the ground from the point of impact to a point directly beneath the airplane at the instant of impact.

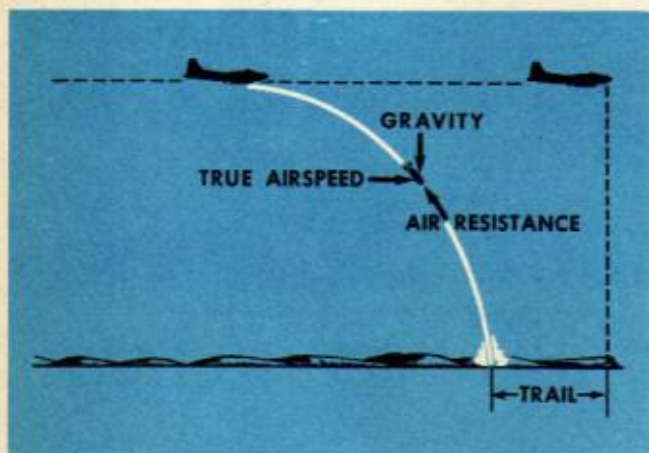

Remember that trail is the result of several forces acting upon the bomb. While TAS drives the bomb forward, air resistance tends to hold it back. While gravity pulls it down, air resistance tends to hold it up. When TAS increases, the horizontal resistance of the air increases; thus, trail is greater. Similarly, when the downward speed of the bomb increases, the vertical resistance of the air increases and trail is greater. The downward speed of the bomb de-

pends on the height of the airplane above the target, that is, the **bombing altitude (BA)** from which the bomb is dropped.

The amount of resistance which the air offers to the bomb also depends on its size, shape, and weight. Ordnance engineers classify a bomb according to its ballistic coefficient (Ball. Coeff.), the relative amount of resistance the air offers to it. A bomb with a high ballistic coefficient falls faster and with less trail than a bomb with a low ballistic coefficient.

The amount of trail for each bomb at practical BA and TAS ranges has been determined by tests and is given in your bombing tables.

Trail increases as $\left\{ \begin{array}{l} \text{BA increases} \\ \text{TAS increases} \\ \text{Ball. Coeff. decreases} \end{array} \right.$

Wind

In addition to the forces of gravity, TAS, and air resistance, **wind** acts upon the bomb during its flight and affects the trajectory. Think of wind as the movement of the mass of air in which the airplane is flying. Wind does not affect the TAS of the airplane. Therefore, it has no effect on trail, since trail depends only on TAS, BA, and type of bomb.

Headwinds or tailwinds do affect the **ground-speed (GS)** of the airplane. When there is a tailwind it increases GS. Therefore, you must release the bomb at a greater distance from the target in order to hit it. Conversely, when there is a headwind, you must release the bomb closer to the target.

When there is a crosswind, **drift** enters the bombing problem. To compensate for drift you head the airplane into the wind sufficiently to make good a course the proper distance upwind of the target. This distance that the airplane must fly upwind of the target is **crosstrail (CT)**. In other words, CT is the distance that the bomb is carried downwind while it is falling.



Actual Time of Fall

The time factor you must know to solve the range problem is the **actual time of fall (ATF)** of the bomb. It is the time that elapses between the release and impact of the bomb.

ATF depends primarily on BA but it is affected also by TAS and bomb ballistics. If air resistance did not affect the fall of the bomb you could find the approximate ATF by the equation, $Time = \frac{1}{4} \sqrt{BA}$. Since air does retard the fall of the bomb, ATF for each type of bomb at practical BA and TAS ranges had to be found by actual tests and is given in your bombing tables.

You set ATF into the M-series bombsight as a **disc speed (DS)**. You can find DS by dividing ATF into 5300, the **bombsight constant**. Thus $DS = 5300/ATF$. DS for each type of bomb through practical BA and TAS ranges also is given in your bombing tables.

DS decreases as $\left\{ \begin{array}{l} \text{BA increases} \\ \text{TAS increases} \\ \text{Ball. Coeff. decreases} \end{array} \right.$

Ranges

Groundspeed is the **rate** factor you must know to solve the range problem. When you synchronize, your bombsight solves for GS and combines it with ATF to find the distance, **whole range (WR)**. WR is the horizontal distance the airplane travels during ATF. You can find it by the equation,

$$WR (ft) = ATF (sec) \times GS (ft/sec)$$

Since the bomb lags trail distance behind the airplane, you subtract trail from WR to find **actual range (AR)**. Thus $AR = WR - Trail$. AR is the horizontal distance the bomb travels during ATF.

Angles

When you look at the target through the bombsight optics, you look along an imaginary line from the bombsight to the target. This is the **line of sight**.

The axis of the vertical gyro is the vertical line of reference the bombsight uses in solving the bombing problem. This reference may or may not be in the **true vertical**, perpendicular to the earth. Only if you level the bubbles perfectly do you establish the gyro axis in the true vertical.

The angle between the bombsight vertical reference and the line of sight at any instant is the **sighting angle (Sight L)**. As the airplane approaches the target, the line of sight sweeps toward the vertical and the Sight \angle decreases toward 0° .

The particular Sight \angle set up by the bombsight at the instant of bomb release is the **dropping angle (Drop L)**. The Drop \angle is the angle between line of sight and bombsight vertical reference at the instant of bomb release. The Sight \angle and the Drop \angle are measured from the bombsight vertical reference you set up, whether it is the true vertical or not.

The angle between the line of sight and the true vertical at any instant is the **range angle (Range L)**. It differs from the Sight \angle by the amount the bombsight vertical reference is out of true vertical.

The angle that subtends the AR of the bomb is the **actual range angle (ARL)**. If the bombing problem has been solved properly and the vertical reference set up is in the true vertical, the Drop \angle is the same as the ARL and subtends the AR of the bomb.

The angle that subtends the WR is the **whole range angle (WRL)**.

The angle that subtends trail is the **trail angle (Trail L)**. Trail is given and used in terms of mils.

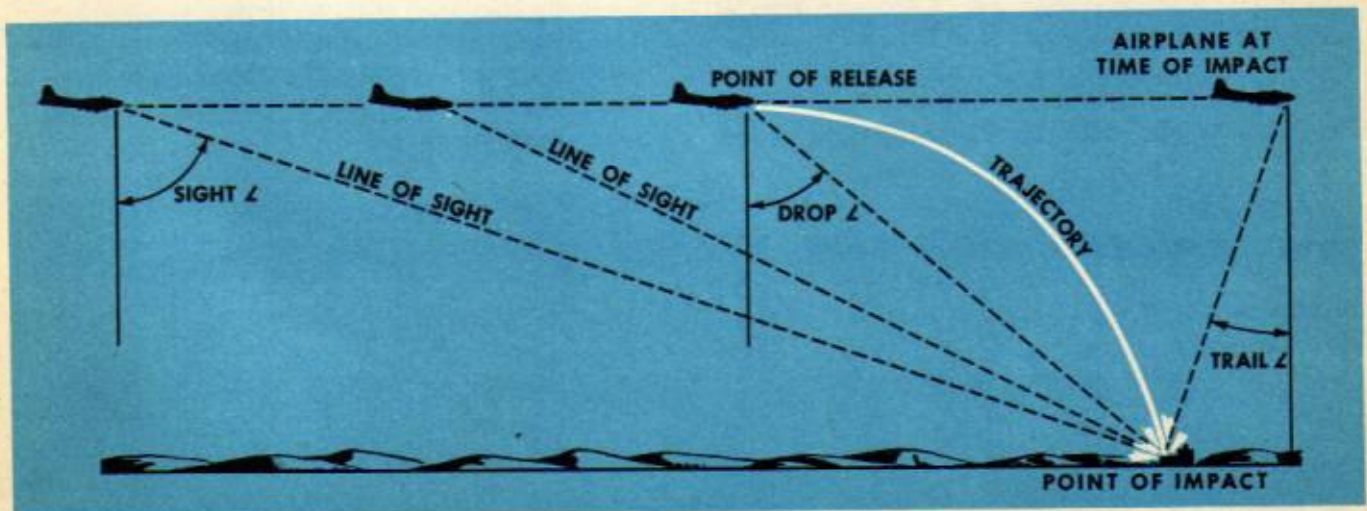

Tangents of Angles

You can express the size of an angle in terms of its tangent. The tangent of an angle in a right triangle is the number you get when you divide the length of the side opposite the angle by the length of the side adjacent to the angle.

$$\text{Tangent} = \frac{\text{Opposite side}}{\text{Adjacent side}}$$

The particular tangent which you read on the bombsight tangent scale is the tangent of the dropping angle (**Tan Drop \angle**). The side that is opposite the Drop \angle is AR; the side adjacent is BA.

$$\text{Therefore, Tan Drop } \angle = \frac{AR}{BA}$$

$$\text{In the same way, Tan WR } \angle = \frac{WR}{BA}$$

$$\text{and Tan Trail } \angle = \frac{\text{Trail}}{BA}$$

Trail is measured in mils (m). A mil is an angle that has a tangent of .001. An angle of 60 mils has a tangent of .060; an angle of 650 mils has a tangent of .650. Actually, the tangent of an angle is the number of mils in the angle divided by 1000, and vice versa.

$$\text{Thus Tan Trail } \angle = \frac{\text{Trail } (m)}{1000}$$

The bombing mil subtends a distance on the ground equal to 1/1000 of the BA. Therefore:

$$\text{Trail (ft)} = \frac{\text{Trail } (m) \times BA}{1000}$$

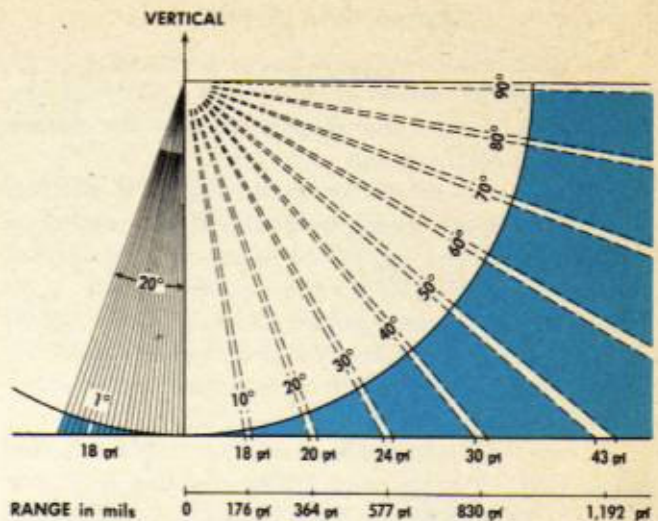

At a BA of 1000 feet, 1 mil of trail subtends 1 foot; at a BA of 8000 feet, 50 mils of trail subtend 400 feet.

An angle of 1° has a tangent value of .01745 and equals 17.45 mils. In working with angles of less than 20° you can say for all practical purposes that 1° = 18 mils.

You can find Tan WR \angle by adding Tan Trail \angle to Tan Drop \angle . Thus Tan WR \angle = Tan Drop \angle + Tan Trail \angle . You read the Tan Drop \angle directly from the bombsight. You read the Trail \angle in mils from the trail plate and find its tangent value by dividing it by 1000.

Solution of Course Problem

Trail and DS are the 2 factors you set into the bombsight. Knowing your BA, TAS, and type of bomb, you obtain the trail and DS (ATF) values from the bombing tables.

You keep the line of sight (fore and aft crosshair) on the target by adjusting the bombsight course

knobs. This crabs the airplane into the wind, if there is a crosswind, and sets up the Drift \angle . During this operation the trail set into the bombsight is automatically combined with the Drift \angle to solve for CT. This tilts the optics enough to direct the airplane CT distance upwind of the target. Thus you have set up the proper course to the target and are ready to synchronize for range.

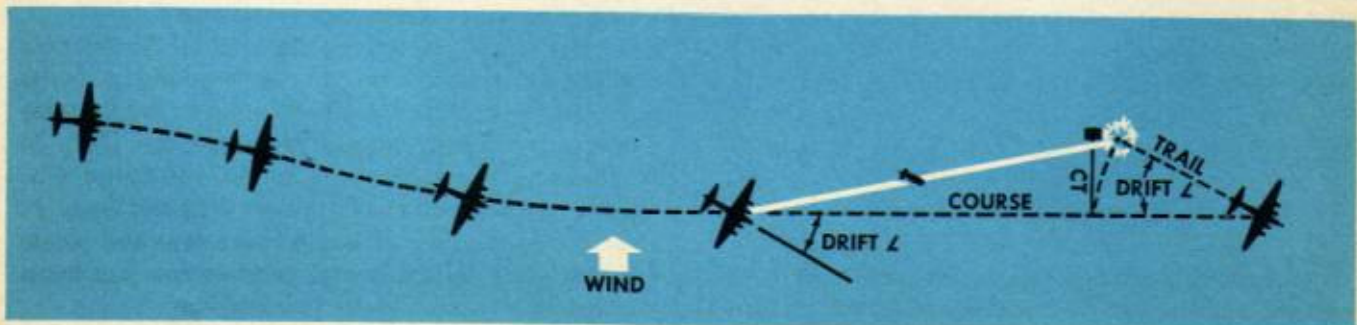

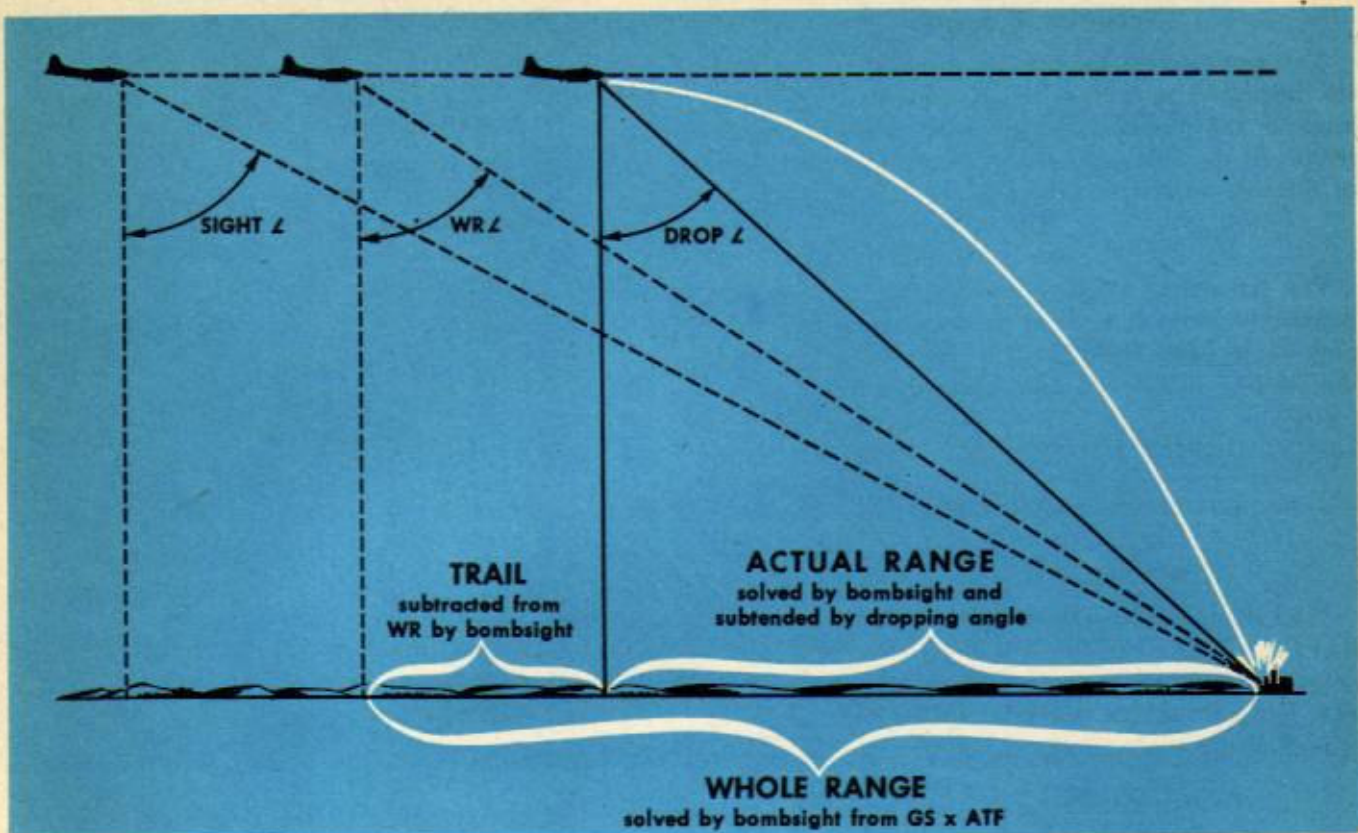

Solution of Range Problem

You synchronize the line of sight (lateral cross-hair) on the target to solve for GS by adjusting the bombsight range knobs. Your bombsight solves for WR by multiplying this GS by the DS (ATF) you previously set into it. During this operation the trail set into the bombsight is automatically subtracted from WR, leaving AR. At the same time the bombsight sets up the Drop \angle that subtends this AR. When the Sight \angle reaches the Drop \angle the bomb is released automatically.

RCCT

When a crosswind exists, there is an inherent error in the bombsight's solution of the bombing problem. It is always an error over and is called **range component of crosstrail (RCCT)**. You have this error because the bombsight measures trail along the course of the airplane, whereas trail actually occurs along the line of heading.

The equation for computing RCCT is:

$$RCCT = \text{Trail} (1 - \text{Cos Drift } \angle)$$

Notice that RCCT depends on the amount of trail and the size of the Drift \angle . In low and medium alti-

tude bombing, trail and drift are usually small enough so that the over caused by RCCT is negligible. However, RCCT produces a significant error when a high speed bomber, flying at a high altitude, encounters a large drift.

Moving Targets

Bombing a target that is moving in a straight line at a constant speed presents no more difficulties of solution than when a wind is present. The bombsight develops WR, AR, and Drop \angle by analyzing the speed of closure between itself and the target, that is, the speed at which the distance between them is closed. Furthermore, a target moving across the course presents the same problem as a stationary target does when there is a crosswind.

If the target maneuvers instead of proceeding straight at constant speed, the bombing problem becomes more difficult. All attempts to synchronize result in continual changes of course and Drop \angle . In bombing a maneuvering target you must synchronize as best you can or pre-set drift and Drop \angle , then aim to the rear of target movement and inside its turn. Only by study and practice can you learn the distance to move your point of aim.

BOMB, C. P., 500-LB., AN. MAC. AN. MIA. OR AN. MIAKI

ALT. foot	DS CONSTANT 5300				TIME OF FLIGHT IN SECONDS				Trail in MILS
	300	300	400	400	300	300	400	400	
16000	161.7	160.8	159.2	157.9	32.72	32.72	32.95	33.19	180
15100	161.3	160.4	158.8	157.5	32.80	32.80	33.03	33.26	170
14200	160.9	159.9	158.3	157.0	32.88	32.88	33.11	33.34	160
13300	160.5	159.5	157.9	156.6	32.96	32.96	33.19	33.42	150
12400	160.1	159.1	157.5	156.2	33.04	33.04	33.27	33.50	140
11500	159.7	158.7	157.1	155.8	33.12	33.12	33.35	33.58	130
10600	159.3	158.3	156.7	155.4	33.20	33.20	33.43	33.66	120
9700	158.9	157.9	156.3	155.0	33.28	33.28	33.51	33.74	110
8800	158.5	157.5	155.9	154.6	33.36	33.36	33.59	33.82	100
7900	158.1	157.1	155.5	154.2	33.44	33.44	33.67	33.90	90
7000	157.7	156.7	155.1	153.8	33.52	33.52	33.75	33.98	80
6100	157.3	156.3	154.7	153.4	33.60	33.60	33.83	34.06	70
5200	156.9	155.9	154.3	153.0	33.68	33.68	33.91	34.14	60
4300	156.5	155.5	153.9	152.6	33.76	33.76	33.99	34.22	50
3400	156.1	155.1	153.5	152.2	33.84	33.84	34.07	34.30	40
2500	155.7	154.7	153.1	151.8	33.92	33.92	34.15	34.38	30
1600	155.3	154.3	152.7	151.4	34.00	34.00	34.23	34.46	20
700	154.9	153.9	152.3	151.0	34.08	34.08	34.31	34.54	10

ALT. foot	Ground speed, miles per hour			
	300	300	400	400
16000	161.7	160.8	159.2	157.9
15100	161.3	160.4	158.8	157.5
14200	160.9	159.9	158.3	157.0
13300	160.5	159.5	157.9	156.6
12400	160.1	159.1	157.5	156.2
11500	159.7	158.7	157.1	155.8
10600	159.3	158.3	156.7	155.4
9700	158.9	157.9	156.3	155.0
8800	158.5	157.5	155.9	154.6
7900	158.1	157.1	155.5	154.2
7000	157.7	156.7	155.1	153.8
6100	157.3	156.3	154.7	153.4
5200	156.9	155.9	154.3	153.0
4300	156.5	155.5	153.9	152.6
3400	156.1	155.1	153.5	152.2
2500	155.7	154.7	153.1	151.8
1600	155.3	154.3	152.7	151.4
700	154.9	153.9	152.3	151.0

ALT. foot	Trail in MILS			
	300	300	400	400
16000	180	170	160	150
15100	170	160	150	140
14200	160	150	140	130
13300	150	140	130	120
12400	140	130	120	110
11500	130	120	110	100
10600	120	110	100	90
9700	110	100	90	80
8800	100	90	80	70
7900	90	80	70	60
7000	80	70	60	50
6100	70	60	50	40
5200	60	50	40	30
4300	50	40	30	20
3400	40	30	20	10
2500	30	20	10	0
1600	20	10	0	0
700	10	0	0	0

ALT. foot	Ground speed, miles per hour			
	300	300	400	400
16000	161.7	160.8	159.2	157.9
15100	161.3	160.4	158.8	157.5
14200	160.9	159.9	158.3	157.0
13300	160.5	159.5	157.9	156.6
12400	160.1	159.1	157.5	156.2
11500	159.7	158.7	157.1	155.8
10600	159.3	158.3	156.7	155.4
9700	158.9	157.9	156.3	155.0
8800	158.5	157.5	155.9	154.6
7900	158.1	157.1	155.5	154.2
7000	157.7	156.7	155.1	153.8
6100	157.3	156.3	154.7	153.4
5200	156.9	155.9	154.3	153.0
4300	156.5	155.5	153.9	152.6
3400	156.1	155.1	153.5	152.2
2500	155.7	154.7	153.1	151.8
1600	155.3	154.3	152.7	151.4
700	154.9	153.9	152.3	151.0

ALT. foot	Trail in MILS			
	300	300	400	400
16000	180	170	160	150
15100	170	160	150	140
14200	160	150	140	130
13300	150	140	130	120
12400	140	130	120	110
11500	130	120	110	100
10600	120	110	100	90
9700	110	100	90	80
8800	100	90	80	70
7900	90	80	70	60
7000	80	70	60	50
6100	70	60	50	40
5200	60	50	40	30
4300	50	40	30	20
3400	40	30	20	10
2500	30	20	10	0
1600	20	10	0	0
700	10	0	0	0

ALT. foot	Ground speed, miles per hour			
	300	300	400	400
16000	161.7	160.8	159.2	157.9
15100	161.3	160.4	158.8	157.5
14200	160.9	159.9	158.3	157.0
13300	160.5	159.5	157.9	156.6
12400	160.1	159.1	157.5	156.2
11500	159.7	158.7	157.1	155.8
10600	159.3	158.3	156.7	155.4
9700	158.9	157.9	156.3	155.0
8800	158.5	157.5	155.9	154.6
7900	158.1	157.1	155.5	154.2
7000	157.7	156.7	155.1	153.8
6100	157.3	156.3	154.7	153.4
5200	156.9	155.9	154.3	153.0
4300	156.5	155.5	153.9	152.6
3400	156.1	155.1	153.5	152.2
2500	155.7	154.7	153.1	151.8
1600	155.3	154.3	152.7	151.4
700	154.9	153.9	152.3	151.0

ALT. foot	Trail in MILS			
	300	300	400	400
16000	180	170	160	150
15100	170	160	150	140
14200	160	150	140	130
13300	150	140	130	120
12400	140	130	120	110
11500	130	120	110	100
10600	120	110	100	90
9700	110	100	90	80
8800	100	90	80	70
7900	90	80	70	60
7000	80	70	60	50
6100	70	60	50	40
5200	60	50	40	30
4300	50	40	30	20
3400	40	30	20	10
2500	30	20	10	0
1600	20	10	0	0
700	10	0	0	0

ALT. foot	Ground speed, miles per hour			
	300	300	400	400
16000	161.7	160.8	159.2	157.9
15100	161.3	160.4	158.8	157.5
14200	160.9	159.9	158.3	157.0
13300	160.5	159.5	157.9	156.6
12400	160.1	159.1	157.5	156.2
11500	159.7	158.7	157.1	155.8
10600	159.3	158.3	156.7	155.4
9700	158.9	157.9	156.3	155.0
8800	158.5	157.5	155.9	154.6
7900	158.1	157.1	155.5	154.2
7000	157.7	156.7	155.1	153.8
6100	157.3	156.3	154.7	153.4
5200	156.9	155.9	154.3	153.0
4300	156.5	155.5	153.9	152.6
3400	156.1	155.1	153.5	152.2
2500	155.7	154.7	153.1	151.8
1600	155.3	154.3	152.7	151.4
700	154.9	153.9	152.3	151.0

ALT. foot	Trail in MILS			
	300	300	400	400
16000	180	170	160	150
15100	170	160	150	140
14200	160	150	140	130
13300	150	140	130	120
12400	140	130	120	110
11500	130	120	110	100
10600	120	110	100	90
9700	110	100	90	80
8800	100	90	80	70
7900	90	80	70	60
7000	80	70	60	50
6100	70	60	50	40
5200	60	50	40	30
4300	50	40	30	20
3400	40	30	20	10
2500	30	20	10	0
1600	20	10	0	0
700	10	0	0	0

ALT. foot	Ground speed, miles per hour			
	300	300	400	400
16000	161.7	160.8	159.2	157.9
15100	161.3	160.4	158.8	157.5
14200	160.9	159.9	158.3	157.0
13300	160.5	159.5	157.9	156.6
12400	160.1	159.1	157.5	156.2
11500	159.7	158.7	157.1	155.8
10600	159.3	158.3	156.7	155.4
9700	158.9	157.9	156.3	155.0
8800	158.5	157.5	155.9	154.6
7900	158.1	157.1	155.5	154.2
7000	157.7	156.7	155.1	153.8
6100	157.3	156.3	154.7	153.4
5200	156.9	155.9	154.3	153.0
4300	156.5	155.5	153.9	152.6
3400	156.1	155.1	153.5	152.2
2500	155.7			

Tables of DS for use with 150-mil trail setting have been prepared for cases in which you have trail values too large to set into the bombsight. You must offset your aiming point to compensate for the extra crosstrail.

For example, suppose the drift is 15° and the trail for a particular bomb is 267 mils. You set the maximum trail of 150 mils into the bombsight and set a faster DS to compensate for the trail deficiency of 117 mils in range.

BOMB, G. P., 100-LB., AN-M30 OR AN-M30A1
TABLE OF DS FOR USE WITH 150-MIL TRAIL SETTING
DS CONSTANT 5300

ALT. feet	True air speed—miles per hour									
	260	280	300	320	340	360	380	400	420	440
16000	153.5	156.0	158.4	160.7	162.8	164.8	166.7	168.5	170.3	172.1
17000	144.0	146.1	148.1	150.1	152.0	153.9	155.7	157.5	159.3	161.2
18000	143.6	146.1	148.4	150.6	152.7	154.6	156.4	158.2	160.0	161.7
18100	143.2	145.7	148.0	150.2	152.3	154.2	156.0	157.8	159.5	161.2

By using the DS tables prepared for a 150-mil trail setting you find the distance to offset your aiming point given as 360 feet for each 10° of drift. Your 15° of drift would give 1.5 × 360, or 540 feet that you must offset your aiming point upwind.

Aiming point, offset upwind in feet,
for each 10 degrees of drift
(Trail setting at 150 mils)

ALT. feet	True air speed—miles per hour				
	280	320	360	400	440
18000	30	120	220	330	460
	30	130	240	360	500
	30	140	260	390	540

The DS values given in the tables have been increased to compensate for the trail deficiency in range. The values, however, are based upon TAS and compensate for the trail deficiency at that TAS only. Since these tables are based upon TAS you must make a DS correction to compensate for existing range winds. The DS corrections are provided in a table which gives the effect of a 10 mph range wind on DS.

For example, if you have a bombing altitude of 18,000 feet, TAS of 400 mph, and a range headwind

Effect of a 10-mile per hour
range wind on DS
(Subtract for tail wind, add for head wind)

ALT. feet	True air speed—miles per hour				
	280	320	360	400	440
18000	0.1	0.2	0.4	0.4	0.5
	0.1	0.2	0.3	0.4	0.5
	0.1	0.2	0.3	0.4	0.5

of 20 mph, the DS correction is 20/10 × .4, or .8 rpm. You add this correction to the DS given in the tables when you have a headwind.

Some of the bombsights currently used have 230 mils as the upper limit of the trail setting instead of 150. Tables have been prepared for these bombsights which are identical with those for a maximum trail setting of 150 mils, except that they provide proper DS corrections for a 230-mil trail setting.

When you use the Glide Bombing Attachment (GBA) you must set a vacuum DS into the bombsight and a DS correction into the GBA. You can find the vacuum DS in the vacuum DS table, reproduced below, or you can find it in the equation:

$$\text{Vacuum DS} = \frac{21250}{\sqrt{BA}}$$

Vacuum DS for Any Bomb

BA (ft)	Vacuum DS (rpm)	BA (ft)	Vacuum DS (rpm)
5000	300.6	16,000	167.7
6000	274.3	17,000	162.9
7000	254.1	18,000	158.8
8000	237.6	19,000	154.2
9000	223.6	20,000	150.2
10,000	212.5	21,000	146.2
11,000	202.6	22,000	143.2
12,000	193.9	23,000	139.6
13,000	186.4	24,000	137.1
14,000	179.6	25,000	134.1
15,000	173.5	26,000	131.5

You must set the DS correction into the GBA for your particular bomb, TAS, glide speed, and the predicted BA of release.

You set trail for the type of bomb, TAS, and predicted BA of release into the bombsight as if you were bombing from level flight. This introduces a range error which is compensated for in the DS correction given in your bombing tables.

Suppose, for example, you are using the AN-M30A1, 100-lb. GP bomb at a BA of 20,000 feet, a TAS of 300 mph, and a glide speed of 2000 ft/min. You set a vacuum DS of 150.2 rpm and a trail of 173 mils into the bombsight. Then set a DS correction of 13.9 rpm into the GBA.

Altitude—20,000 feet

Glide speed, ft/min	True air speed—miles per hour					
	150	200	250	300	350	400
-2000	13.0	13.2	13.6	14.1	14.8	15.5
1500	12.4	12.8	13.3	13.9	14.5	15.2
2000	12.4	12.8	13.3	13.9	14.5	15.2

BOMBING ERRORS

Errors for the most part are the same in synchronous and fixed-angle bombing. However, incorrect bombing altitude and incorrect airspeed cause errors in one direction in synchronous bombing and in the opposite direction in fixed-angle bombing. For this reason fixed-angle bombing errors are discussed separately.

SYNCHRONOUS BOMBING ERRORS

Errors in synchronous bombing result from: improper vertical; improper ATF; improper trail; improper course; improper rate; and improper release.

Improper Vertical

You level the bubbles to establish the vertical reference from which the course is aligned and the Drop \angle is measured. When properly centered, either bubble is cut in half by its lubber line. As the gyro gets out of the vertical, the bubbles move toward its high side. If one end of either bubble is under its lubber line, the bubble is $\frac{1}{2}$ bubble length off.

Lateral Bubble. If the lateral bubble is to the left of center, the top of the gyro axis is tilted to the right. The top of the optics is also tilted to the right. Thus the airplane is directed too far to the right of the target and the bomb hits to the **right**. The tilt of the gyro axis and optics is **approximately 1° or 18 mils** when the lateral bubble is $\frac{1}{2}$ bubble length off.

The deflection error in feet resulting from an improperly centered lateral bubble is equal to:

$$\frac{BA}{1000} \times \text{bubble error in mils}$$

Fore and Aft Bubble. If the fore and aft bubble is to the front of center, the top of the gyro axis and the top of the optics are tilted to the rear. Accordingly, the bombsight vertical reference is out of the true vertical. The line of sight is swung upward and forward from its normal position without moving the sighting angle index. Thus the Range \angle is larger than the Sight \angle indicated by the sighting angle index. As a result of this, the sighting angle index

reaches coincidence with the dropping angle index too soon and the bomb hits **short**.

Part of this error is compensated for when you synchronize for GS. When the line of sight is forward and upward from its normal position, it is not in proper alignment with the mirror drive quadrant. With the line of sight in this position the mirror drive quadrant drives at a faster rate than needed. Consequently, when synchronizing the line of sight on the target you set up a slower movement of the mirror drive quadrant. Thus you set up a smaller Drop \angle , which tends to cause the bomb to hit **over**. This tends to compensate for part of the error short.

The range error in feet resulting from an improperly centered fore and aft bubble is equal to:

$$\frac{\tan(\text{Drop } \angle + 1\frac{1}{2}^\circ) - \tan(\text{Drop } \angle + \frac{1}{2}^\circ)}{\tan(\text{Drop } \angle + \frac{1}{2}^\circ) - \tan(\text{Drop } \angle - \frac{1}{2}^\circ)} \tan \text{Drop } \angle - \tan(\text{Drop } \angle + 1^\circ)$$

RANGE ERROR CAUSED BY FORE AND AFT BUBBLE ERROR OF 1° ($\frac{1}{2}$ BUBBLE LENGTH)

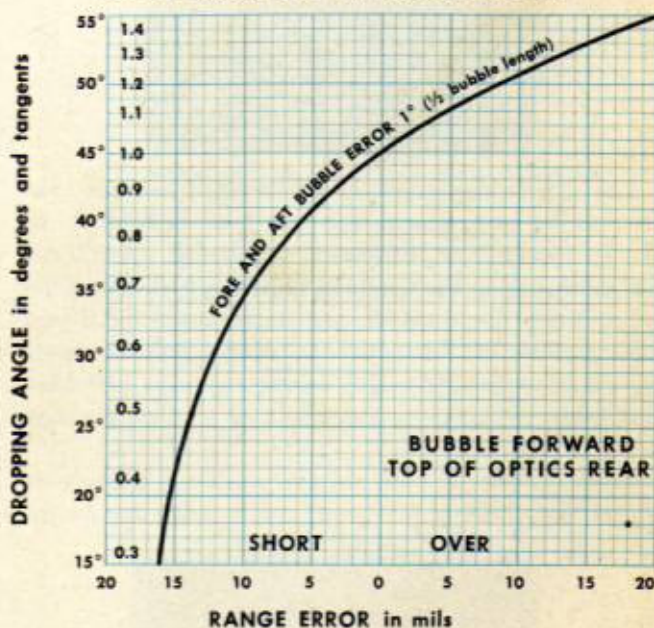

When using the above equation and chart, you must assume that you refine range synchronization up to the point of release and are synchronized at release.

For practical purposes you can assume that when the fore and aft bubble is off 1/2 bubble length the resulting error is the same in size as when the lateral bubble is off 1/2 bubble length. Or you can use the average of the chart, which is about 14 mils for 1° tilt.

Level the bubbles only when the airplane is flying straight and level and at a constant airspeed. Once the bubbles are leveled during the bombing run they tend to remain level. Consequently, once you have established the true vertical, do not attempt to re-center the bubbles each time they move off. Be sure the leveling knobs don't stick.

Remember:

Bubble front — top of optics rear — bomb hits short.
 Bubble left — top of optics right — bomb hits right.

Improper ATF

If the ATF used in setting up the bombsight is too large, the DS is too slow. With the disc rotating too slowly you move the roller too far from the center of the disc when synchronizing for rate. Consequently, the Drop ∠ set up is too large and the bomb hits short.

Similarly, if you are flying too low the DS in the bombsight is too slow and the bomb hits short. For practical purposes you ignore the small trail deficiency when you have only a small altitude variation.

The range error in feet resulting from an improper DS (ATF) set into the bombsight is equal to:

$$GS \text{ (ft/sec)} \times \text{ATF error in seconds}$$

The range error in mils is equal to:

$$\frac{2 \times GS \text{ (mph)}}{100} \times \text{DS error in rpm}$$

or

$$\frac{1000 \times \text{Tan WR}\angle}{DS} \times \text{DS error in rpm}$$

RANGE ERROR CAUSED BY AN ALTITUDE ERROR OF 100 FEET (AN-M64A1, 500-lb. BOMB)

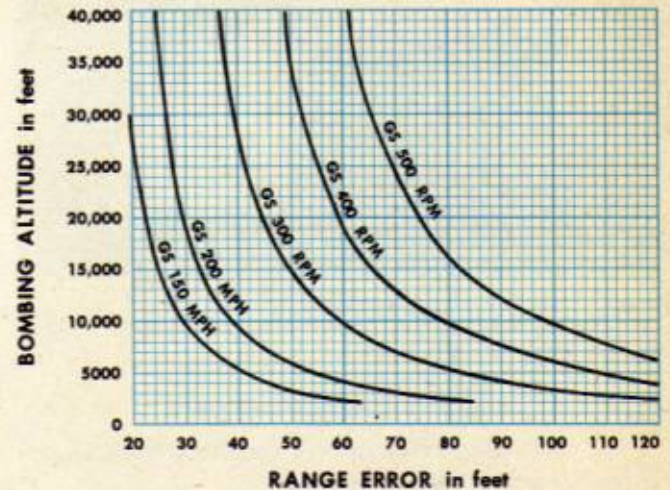

In computing BA be especially careful in reading your altimeter, temperature gage, airspeed indicator, and computer. Check the calibration cards and use the corrections properly. Always subtract the airspeed compression error. Add and subtract carefully and always recheck your TAS and BA computations. In finding DS from bombing tables, be sure you read down correct column and across correct row. After attaining your BA, always recheck DS set into bombsight. If you use a stop watch to check DS, you must have trail arm at 0.

Teach your pilot not to climb or glide near the end of the bombing run. Ask him to notify you if and how much he is off altitude, before reaching bomb release point.

Remember, bomb hits short if:

- DS set into bombsight is too slow.
- ATF set into bombsight is too large.
- BA computed is too high.
- Pilot flies too low.
- Airplane is in glide.
- Altimeter indicates too high.
- Tachometer indicates too fast.

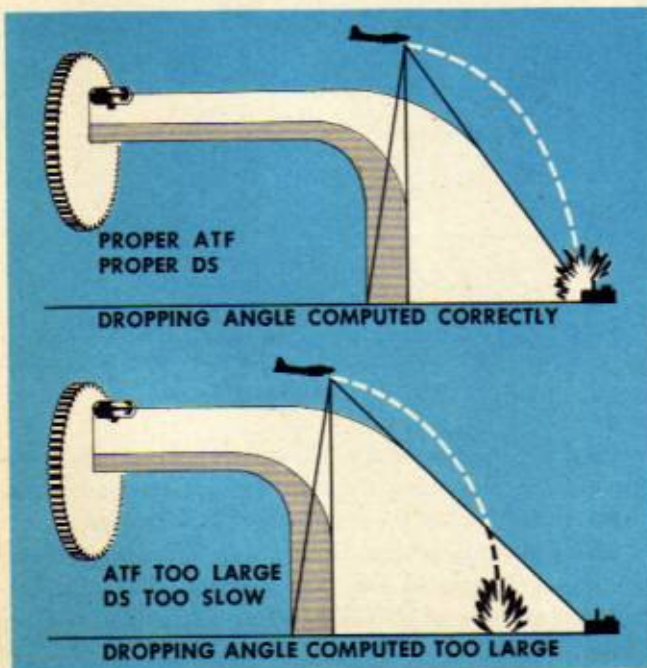

Improper Trail

If the trail set into the bombsight is too small, when you synchronize for range you set up too large a Drop \angle and the bomb hits **short**. When there is drift the bomb also hits **downwind**. That is, with right drift and trail setting too small the bomb hits **right and short**.

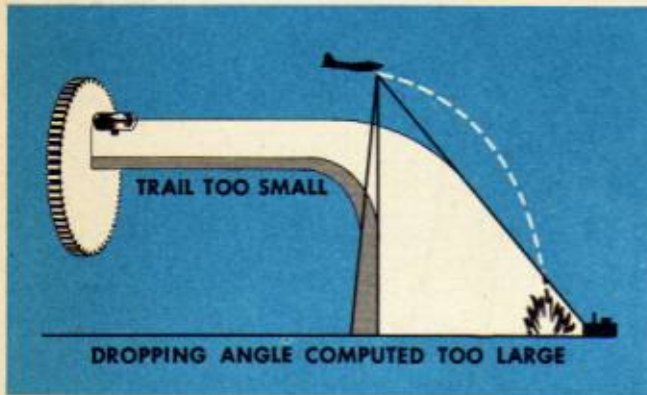

The range error in feet resulting from an improper trail setting is equal to:

$$\frac{BA}{1000} \times \text{Trail error in mils}$$

The deflection error in feet resulting from an improper trail setting is equal to:

$$\text{Trail (ft)} \times \sin \text{Drift } \angle$$

DEFLECTION (CT) ERROR CAUSED BY TRAIL ERROR OF 10 MILS

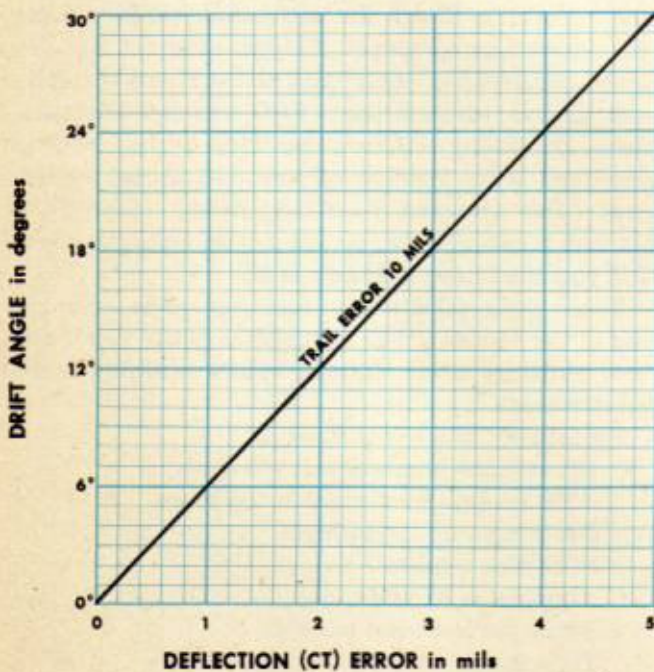

Read your instruments carefully, check calibration cards, and use corrections properly. Always subtract airspeed compression error. Be positive in your computer settings and readings. In finding trail from bombing tables, be sure you read down correct column and across correct row.

Teach your pilot not to jockey the throttle in trying to hold airspeed constant. Ask him to notify you if it is fast or slow and how much, before reaching bomb release point.

Remember, bomb hits **short and downwind** if:

- Trail set into bombsight is too **small**.
- TAS computed is too **slow**.
- Pilot flies too **fast**.
- Airspeed indicator indicates **slow**.
- Bombsight has **negative pre-set trail**.

RCCT. When bombing at high altitudes and high airspeeds, the trail is large. With large trail and a large Drift \angle you get an appreciable error **over**, because of RCCT.

The range error in feet resulting from RCCT is equal to:

$$\text{Train (ft)} \times (1 - \cos \text{Drift } \angle)$$

RANGE ERROR (OVER) CAUSED BY RCCT (Range Component of Crosstrail)

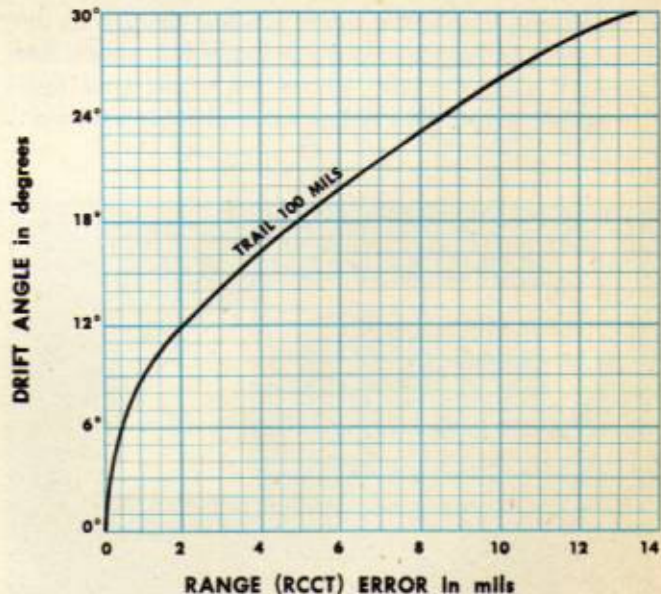

You can decrease the DS or trail to compensate for RCCT. Reducing the trail setting introduces an error in CT unless your bombsight is equipped with a trail spotting device. To reduce DS, find the mil value for 1 rpm of DS. Then divide that into the number of mils of RCCT you expect. This gives the amount to decrease DS.

Improper Course

If you set up a Drift \angle which is too small the airplane is not directed far enough upwind of the target and the bomb hits **downwind**. With too small a right Drift \angle the bomb hits to the **right**.

When you set up an incorrect drift you set up an incorrect course and an incorrect crosstrail. They both occur in the same direction. Their total deflection error in feet is equal to:

$$WR \text{ (ft)} \times \sin \text{ drift error in degrees}$$

or

$$\frac{BA \times \tan WR\angle \times 18}{1000} \times \text{Drift error in degrees}$$

Be thorough in your preflight of stabilizer and course knobs. Pre-set your Drift \angle whenever possible. Make smooth, positive course corrections which are easy for the pilot to follow. Pilot or autopilot should respond to your corrections with smooth, positive, coordinated turns. Make your large corrections **early** in the run, but don't make corrections faster than the pilot can take them out. As you near your release point, you should need only minor adjustments. Keep the fore and aft cross-hair on the target and be careful not to overcorrect.

Teach your pilot how to adjust autopilot properly for bombing. When you set up course manually,

perfect cooperation and coordination between you and your pilot are imperative.

Remember:

- Drift too small—bomb hits downwind.
- Right drift too small—bomb hits right.

DEFLECTION ERROR CAUSED BY COURSE (DRIFT) ERROR OF 1°

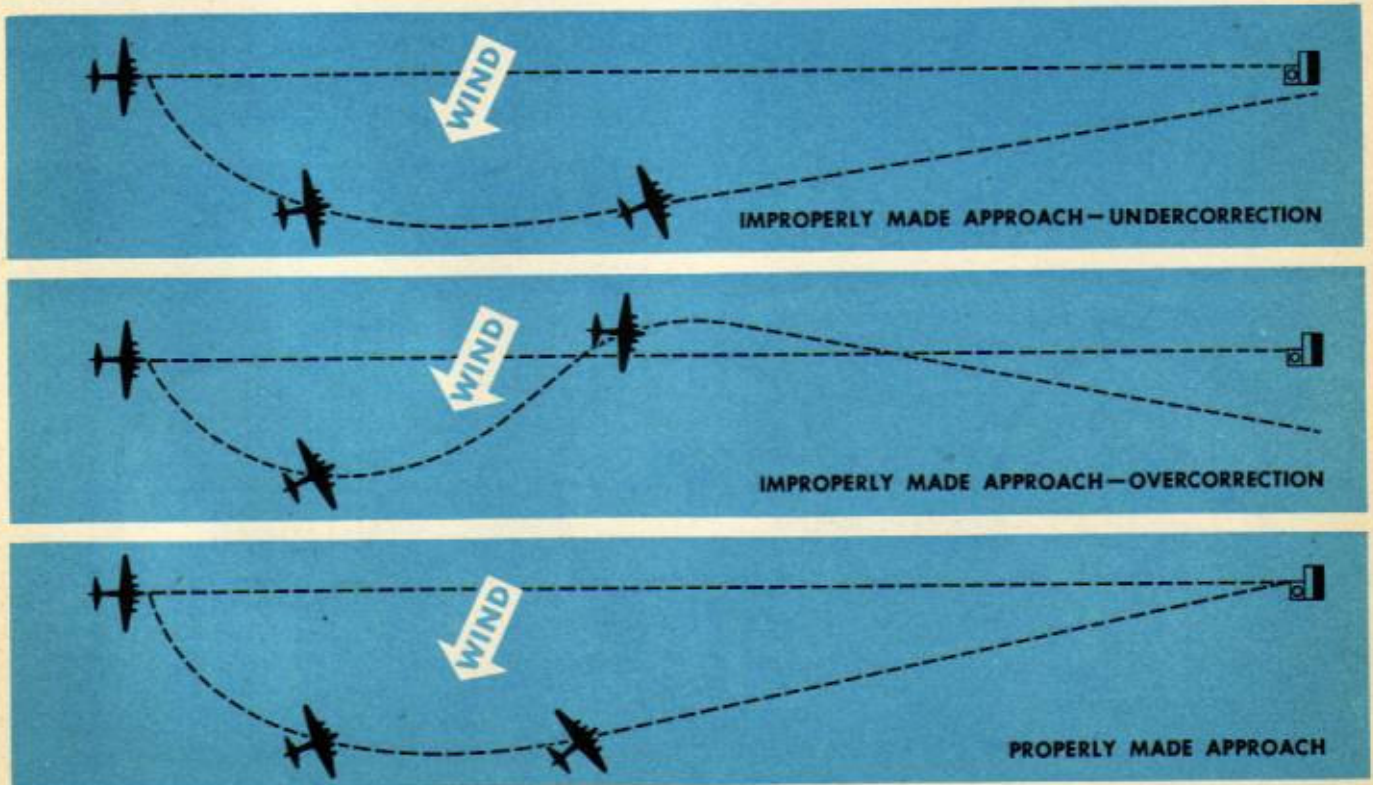
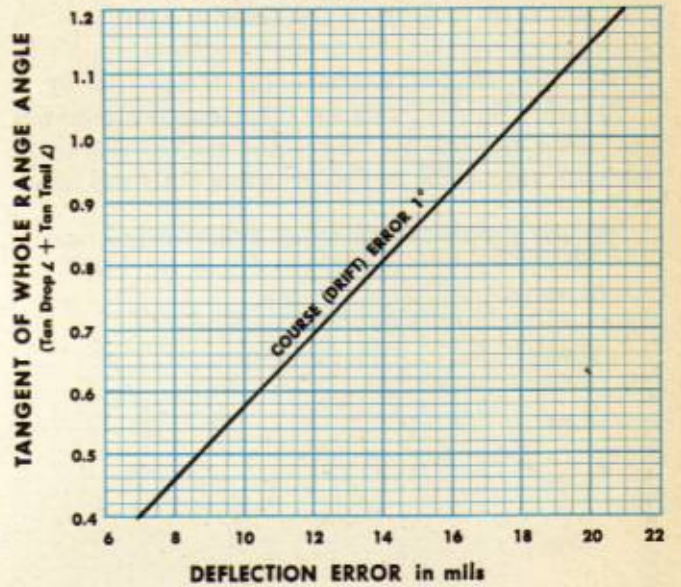

Improper Rate

If the lateral crosshair moves short of the target, or toward you, your rate synchronization is fast. You have solved for a faster GS than actually exists. Consequently, the Drop \angle set up is too large and the bomb hits **short**.

The range error in feet resulting from improper range synchronization is equal to:

$$ATF \times 88/60 \times GS \text{ error in mph}$$

or

$$BA (\text{Tan Drop } \angle \text{ needed} - \text{Tan Drop } \angle \text{ used})$$

To find GS error, take the difference between GS you solve for with the bombsight and GS you solve for with your E-6B computer, using TAS and wind.

RANGE ERROR CAUSED BY GS SYNCHRONIZATION ERROR OF 1 MPH (AN-M64A1, 500-lb GP BOMB)

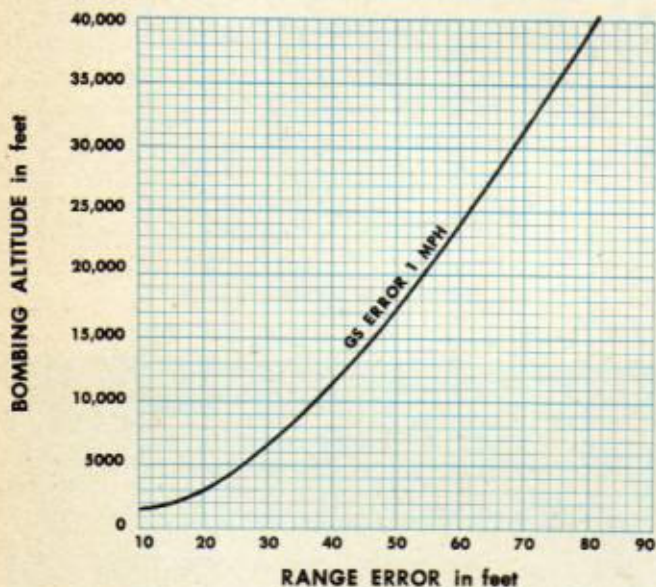

Be thorough in your preflight of bombsight rate end. Pre-set your Drop \angle whenever possible. Set up a good course before attempting to refine rate. You should need only minor adjustments as you near the release point. Keep lateral crosshair on target and do not overcorrect. Be sure that you don't have extended vision rolled in.

Teach your pilot how jockeying airspeed upsets your synchronizing for range. Teach him not to change altitude or airspeed too radically. Teach him to notify you before reaching bomb release point if either altitude or airspeed is off, how much it is off, and which way it is off.

Improper Release

As bombs are usually carried some distance behind the bombsight, they tend to hit that same distance **short** of the target.

After the bombsight has sent the release impulse to the racks, there is a slight delay in releasing the bombs because of rack lag. Allowable lag is from .03 to .06 second, depending on the condition of the racks. Since the bomb is carried longer than the bombsight intends, rack lag tends to cause the bomb to hit **over**. Errors resulting from rack lag are small unless the racks are not kept in proper condition and the lag exceeds the allowable limits.

Improper adjustments of the bombsight release contacts also can cause faulty release. These contacts should close when the sighting angle index reaches coincidence with the dropping angle index. If they close too soon the bomb hits **short**.

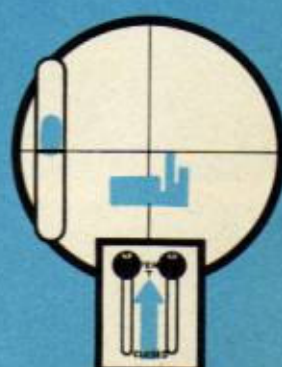
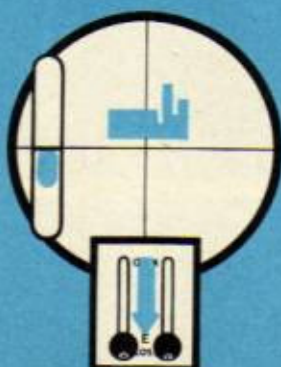
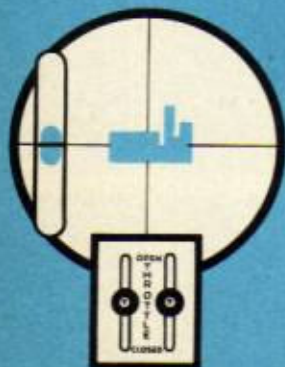

WHEN PILOT JOCKEYS AIRSPEED, BOMBARDIER CANNOT ACCURATELY LEVEL BUBBLES OR SYNCHRONIZE FOR RANGE.

FIXED-ANGLE BOMBING ERRORS

Fixed-angle bombing is subject to about the same errors that occur in synchronous bombing. In fixed-angle bombing, you pre-set the Drop \angle for the BA and GS at which the bomb is to be released. Therefore, you must understand the effect of incorrect BA, TAS, wind, and fore and aft bubble level. Since you pre-set the Drop \angle , be especially careful in obtaining it from the bombing tables.

Incorrect Bombing Altitude

If you release the bomb from a higher BA than used in pre-setting the Drop \angle , the pre-set Drop \angle is too large and the bomb hits **short**.

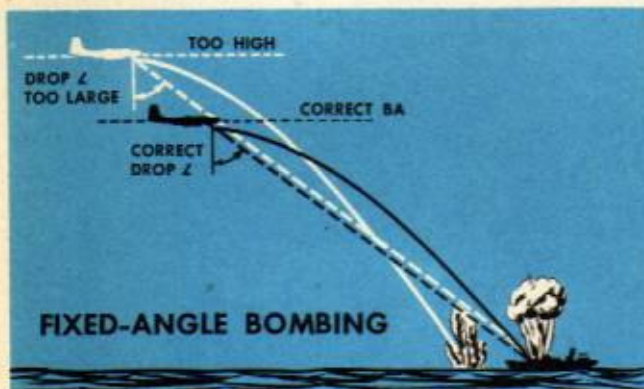

The range error in feet resulting from an incorrect BA is equal to:

$$BA (\tan \text{Drop } \angle \text{ needed} - \tan \text{Drop } \angle \text{ used})$$

From your bombing tables find the Tan Drop \angle needed for the BA actually flown. Tan Drop \angle used is taken from the bombsight.

Incorrect Airspeed

If at the instant of release the airplane is flying at a slower IAS and hence a slower TAS and GS, the pre-set Drop \angle is too large and bomb hits **short**.



The pre-set Drop \angle is larger than needed for the slower GS actually flown. The accuracy of GS and consequently the accuracy of your Drop \angle depends upon the correct solution for the wind. Therefore you must determine the wind accurately when you do fixed-angle bombing.

The range error in feet resulting from an incorrect airspeed is equal to:

$$BA (\tan \text{Drop } \angle \text{ needed} - \tan \text{Drop } \angle \text{ used})$$

or

$$ATF \times \text{TAS error in ft/sec}$$

From your bombing tables find the Tan Drop \angle needed for the GS actually flown.

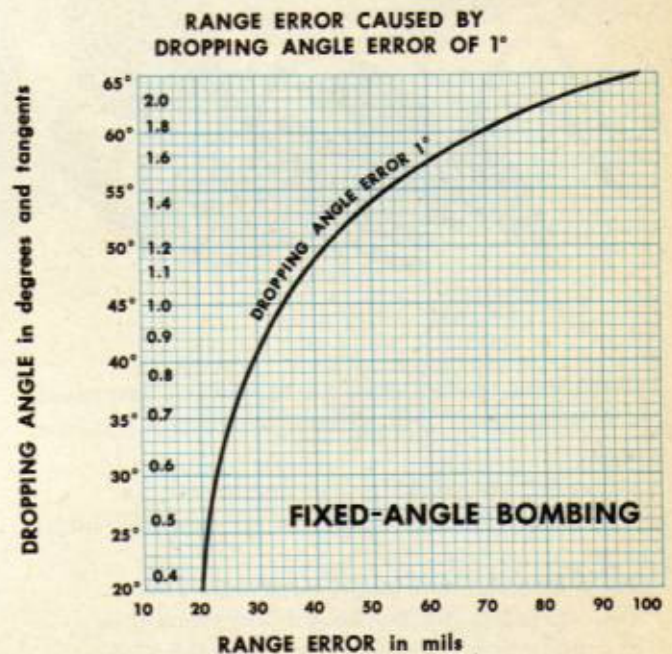

Incorrect Fore and Aft Bubble Level

In fixed-angle bombing, when the fore and aft bubble is forward, the Range \angle at release is larger than the Drop \angle and the bomb hits **short**. Since you do not synchronize for rate you do not have 2 errors which tend to compensate for each other, as you do in synchronous bombing.

The range error in feet resulting from an incorrect fore and aft bubble level is equal to:

$$BA (\tan \text{Drop } \angle - \tan \text{Range } \angle)$$

Remember, in fixed-angle bombing:

Fore and aft bubble **forward**—bomb hits **short**.

BA **too high**—Drop \angle **too large**—bomb hits **short**.

TAS **too slow**—Drop \angle **too large**—bomb hits **short**.

Incorrect bombing altitude or incorrect airspeed causes an error in the opposite direction to that in synchronous bombing.

BOMBING ANALYSIS

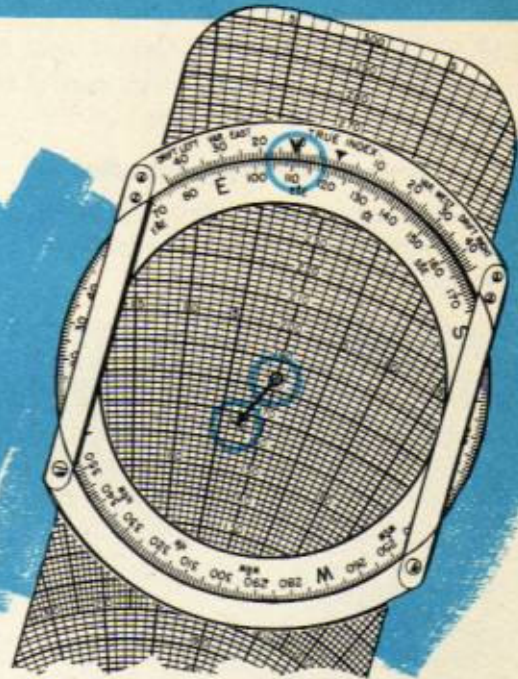

When your bomb misses the target, you can usually attribute it to one or more of these principal causes:

You computed TAS or BA incorrectly; or

You misread DS or trail from the bombing tables and/or

Set it into the bombsight incorrectly; or

You operated the bombsight incorrectly; or

The pilot flew the airplane unsuitably; or

The bombsight functioned improperly.

Plan of Analysis

On every mission, accurately record your data for each release. Then, if your bomb misses the target, study the data for that particular release. Follow a simple plan for analyzing your errors and finding out why they occurred.

Computations of BA and TAS

Carefully check your computations for BA and TAS. If you have any doubt of their accuracy, make a complete recomputation of both.

Bombsight Settings (Trail and DS)

From the bombing tables, obtain the correct trail and DS for your TAS, BA, and type of bomb. Check to see if you set them into the bombsight correctly.

Wind

Plot the wind, which you had over the target at your BA, on your E-6B computer. Use the wind obtained from the most reliable source, such as: metro prediction; navigator's computation; drift and groundspeed solution.

Now, use this wind to find your drift and GS in order to check course and range synchronization.

Range Errors

If your bomb missed the target in range, check for:

1. **Vertical**—level of fore and aft bubble.
2. **ATF**—BA flown and DS setting.
3. **Trail**—TAS flown, trail setting, and RCCT.
4. **Rate**—range synchronization.

Deflection Errors

If your bomb missed the target in deflection, check for:

1. **Vertical**—level of lateral bubble.
2. **CT**—TAS flown and trail setting.
3. **Drift**—course synchronization.

AIDS FOR BOMBARDIERS

A handy source of bombing aids is of great value to you in performing your duties as a bombardier. Such information enables you to do your work quickly and efficiently. It includes reliable short cuts, E-6B solution for GS, mil values of one rpm of DS, how to mark Tan Drop \angle values on E-6B, rules of thumb. It also includes graphs to determine trigonometric functions, GS, and your horizontal distance from the target at any Sight \angle .

Angles and their trigonometric values are useful in making your many computations and in doing analysis. On this single graph you may find the tangent, sine, and cosine functions of any angle you may need and their values are sufficiently accurate for your use.

Groundspeed (mph) is one of the first values which you will want to know when you start to do

bombing analysis. Also this graph is especially convenient when determining the Tan Drop \angle in doing pre-set bombing, for the only calculation necessary is to subtract the trail from the Tan WR \angle . You can make separate computations each time you need GS. However, it is faster to add the Tan Drop \angle and Tan Trail \angle to find the Tan WR \angle . Then use the graph with this Tan WR \angle and the BA to find GS.

Horizontal distance from a sighting angle is especially useful for you to know, for at high altitudes it is rather difficult to estimate distances on the ground. From this graph you can easily determine and learn the horizontal distances for various sighting angles at the bombing altitudes you usually fly. Knowing this distance means that you know how much time you have for your bombing approach, evasive action, bombing run.

CONSTANTS, CONVERSION FACTORS, AND EQUATIONS

5300—The disc speed constant for the M-series bombsight.

7773—The constant used in solving for GS in mph ($5300 \times 88/60$).

18—The approximate number of mils used in determining bubble error of 1° .

88/60—Factor used to change mph to ft/sec. You multiply mph by 88/60 to find ft/sec.

1.15—Factor used to convert knots to mph. You multiply knots by 1.15 to find mph.

$$WR = GS \text{ (ft/sec)} \times ATF$$

$$AR = WR - \text{Trail}$$

$$\text{Tan WR } \angle = \frac{WR}{BA}$$

$$\text{Tan AR } \angle = \frac{AR}{BA} = \text{Tan Drop } \angle$$

$$\text{Tan Trail } \angle = \frac{\text{Trail (ft)}}{BA} = \frac{\text{Trail (mil)}}{1000}$$

$$\text{Trail (ft)} = \text{Trail (mil)} \times \frac{BA}{1000}$$

$$DS = \frac{5300}{ATF}$$

$$GS \text{ (ft/sec)} = \frac{DS \times BA}{5300} \times \text{Tan WR } \angle$$

$$GS \text{ (mph)} = \frac{DS \times BA}{7773} \times \text{Tan WR } \angle$$

$$CT = \text{Trail} \times \text{Sin Drift } \angle$$

$$RCCT = \text{Trail} (1 - \text{Cos Drift } \angle)$$

$$TAS = CAS + \frac{(CAS \times PA \times .02)}{1000}$$

$$\text{Range error (ft)} = \frac{WR \times DS \text{ error}}{DS}$$

$$\text{Range error (ft)} = GS \text{ (ft/sec)} \times ATF \text{ error}$$

$$\text{Range error (mil)} = \frac{1000 \times \text{Tan WR } \angle \times DS \text{ error}}{DS}$$

$$\text{Range error (mil) for DS error of 1 rpm} = \frac{2 \times GS \text{ (mph)}}{100} \text{ approximately}$$

$$\text{Tan Sight } \angle \text{ (for short bombing run)} = \text{Tan Drop } \angle + \frac{(\text{Tan WR } \angle \times \text{Time of Run})}{ATF}$$

$$\text{Airspeed correction for temperature } (^\circ\text{C}) = -.00008 \times (TAS)^2$$

Finding GS With E-6B Computer

When you compute GS with the E-6B, and data taken from the bombsight, you solve the equation:

$$GS \text{ (mph)} = \frac{DS \times BA}{7773} \times \text{Tan WR } \angle$$

You find that the BA and DS remain constant when you are calibrating instruments or bombing, whereas the Tan WR \angle changes with each change in GS. Use the values of BA and DS in the equation and divide by 7773. The quotient is a constant which you can multiply by the Tan WR \angle for any heading. Thus you find the GS for that heading.

You can make one setting on the computer to solve the first part of the GS equation. For a BA of 20,000 feet the DS is 137 rpm. Therefore, set 7773 on inner scale opposite 20,000 on outer. Opposite 137 on inner scale read the constant 353 on outer.

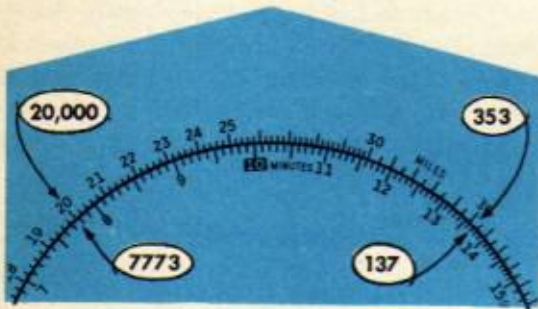

After you find the constant 353, multiply it by Tan WR \angle to determine GS. To do this set 10 on inner scale opposite 353 on outer scale. Opposite Tan WR \angle on inner scale read GS on outer scale. If Tan WR \angle is .68, GS is 240 mph. With this same setting on your computer, provided the BA and DS remain constant, you can find the GS on any heading for the Tan WR \angle you set up on that heading. For a Tan WR \angle of .80 the GS is 282 mph.

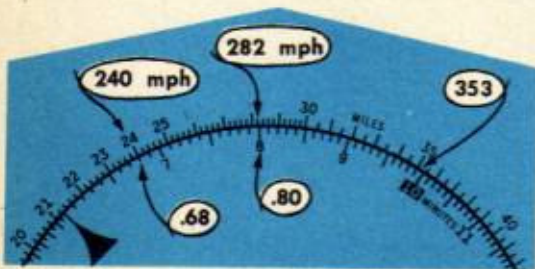

Tan Drop \angle Charts for E-6B Computer

Charts have been prepared for your E-6B with Tan Drop \angle values on them for bombing altitudes

and groundspeeds you are likely to fly and types of bombs you are likely to use. However, if you do not have these charts you can mark the regular chart of the E-6B to serve the same purpose.

Find the Tan WR \angle for the BA and GS which you are most likely to encounter. In addition, you should find the Tan WR \angle for altitudes of 1000 feet and 2000 feet above and below your predicted BA. You should also find the Tan WR \angle for groundspeeds of at least five 10-mph intervals above and below your predicted TAS. From your bombing tables find the trail for your predicted TAS at each of these bombing altitudes. Then subtract each Tan Trail \angle from the respective Tan WR \angle to obtain Tan Drop \angle . Plot each Tan Drop \angle on your chart in an orderly manner.

Suppose your BA is to be approximately 20,000 feet and your TAS 280 mph. Label the centerline of your chart 20,000, label the 5° drift lines 19,000 and 21,000, and the 10° drift lines 18,000 and 22,000.

Using the GS graph or the slide rule of the E-6B, find the Tan WR \angle for each BA and GS of each 10 mph interval from about 230 mph to 330 mph.

When you use the E-6B, find a constant value for the DS \times BA / 7773 portion of the GS equation. At 20,000 feet BA, with the AN-M30A1, 100-lb. GP bomb, this constant is 353. Set 10 on inner scale opposite 353 on outer scale. With this setting opposite each GS on outer scale find the Tan WR \angle on inner scale. If GS is 240 mph the Tan WR \angle is .68.

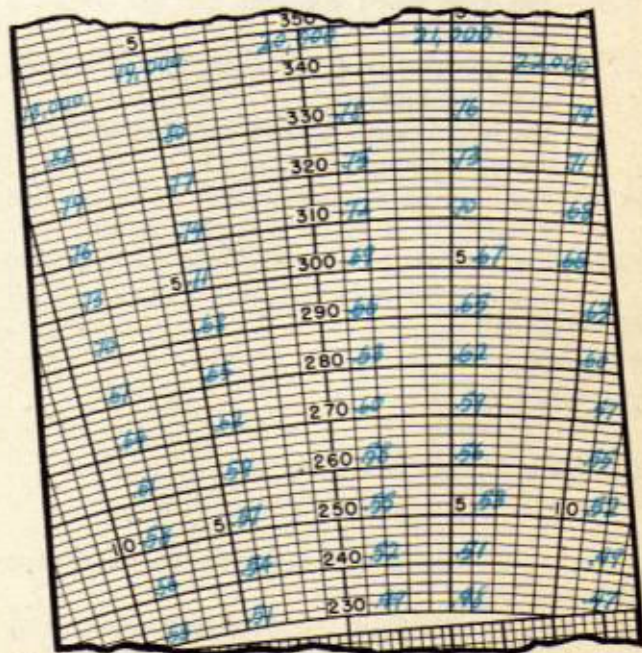

Plot each Tan Drop \angle on your chart in an orderly manner.

Find the trail from your bombing tables and subtract the Tan Trail \angle from the Tan WR \angle . Since the trail is 142 mils, the Tan Drop \angle is .68 - .142, or .538.

Write .54 at the intersection of the 20,000 ft. BA line and the 240 mph GS circle. In the same manner find the Tan Drop \angle for each of the various groundspeeds and bombing altitudes you need and write them in the proper places on the chart. Now, when you set the wind and your heading on your computer you can find the Tan Drop \angle on the GS circle at the point of the wind arrow.

DS Compensation for Trail Deficiency

Special bombing tables have been prepared for use when the trail values exceed the limits of the bombsight. However, if you do not have these tables, you must make the necessary corrections to compensate for deficiency of trail in both range and crosstrail.

You set in a faster DS to make the proper correction in range. For example, suppose you are flying at a BA of 18,000 feet with a TAS of 300 mph and 15° of drift. With the AN-M30A1, 100-lb. GP bomb the trail is 174 mils and the ATF is 36.7 seconds. When you set 150 mils of trail into the bombsight you have a trail deficiency of 24 mils, which is 18 × 24, or 432 feet. To obtain the corrected DS to use, assume that the GS is equal to the TAS. Then use the known values of TAS, ATF, and trail deficiency in the equation:

$$DS = \frac{5300 \times GS \text{ ft/sec}}{(GS \text{ ft/sec} \times ATF) - \text{Trail deficiency in feet}}$$

Thus you have $\frac{5300 \times 300 \times 88/60}{(300 \times 88/60 \times 36.7) - 432}$ or 148 rpm as the corrected DS to set into the bombsight.

You compensate for the deficiency of trail in the crosstrail mechanism by offsetting your aiming point upwind from the target. With 150 mils of trail set into the crosstrail mechanism of the bombsight, there remains 24 mils × sin 15°, or 6.2 mils of crosstrail for which you must compensate. At a BA of 18,000 feet you must offset your aiming point 6.2 × 18, or 112 feet upwind.

Mil Values of 1 rpm DS

You can accurately and conveniently offset the point of bomb impact in range if you know the mil value of 1 rpm of DS at the groundspeed you are flying. To determine this value, simply double the GS and divide by 100.

When doing train bombing you decrease the DS sufficiently to have the first bomb hit a definite num-

ber of mils short, determined by the length of the train. On the other hand, when you have trail values which are too large to set into the bombsight you can compensate for the trail deficiency in range by increasing the DS.

At high altitudes and high airspeeds an error of 1 rpm of DS causes a much greater error in range than at lower altitudes and airspeeds. Consider: When your BA is 8000 feet and the GS is 150 mph, an error of 1 rpm in DS causes an error of only 24 feet on the ground. At a BA of 30,000 feet and a GS of 400 mph, an error of 1 rpm in DS causes an error of 240 feet on the ground.

When you study the graph of range error in mils for each rpm of DS at the different groundspeeds in mph, you can see that if you double the GS and divide by 100 you have the approximate range error in mils for 1 rpm of DS.

For example, suppose your GS is 400 mph. Then the range error is 2 × 400/100, or 8 mils, for an error of 1 rpm in DS. At a BA of 30,000 feet the range error for each rpm error in DS would be 240 feet.

The above calculation just happened to work out in this simple form for the AN-M64A1, 500-lb. GP bomb, though it is accurate enough to use for the other GP bombs. However, if you are using fragmentation or incendiary bombs which have unusually large trail values, you can't use that simple equation. But you can solve the equation:

$$\text{Range Error (ft)} = \frac{1000}{BA} \times \frac{GS \times ATF}{DS} \times \frac{88}{60}$$

and work out a simple rule of thumb for any bomb you may use.

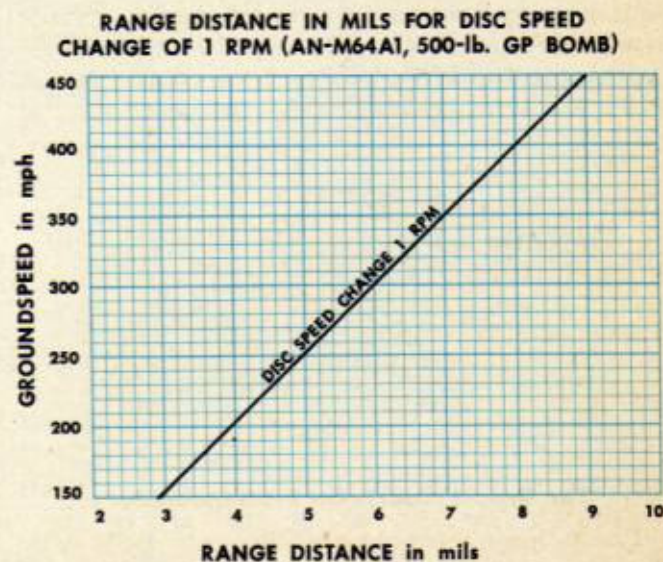

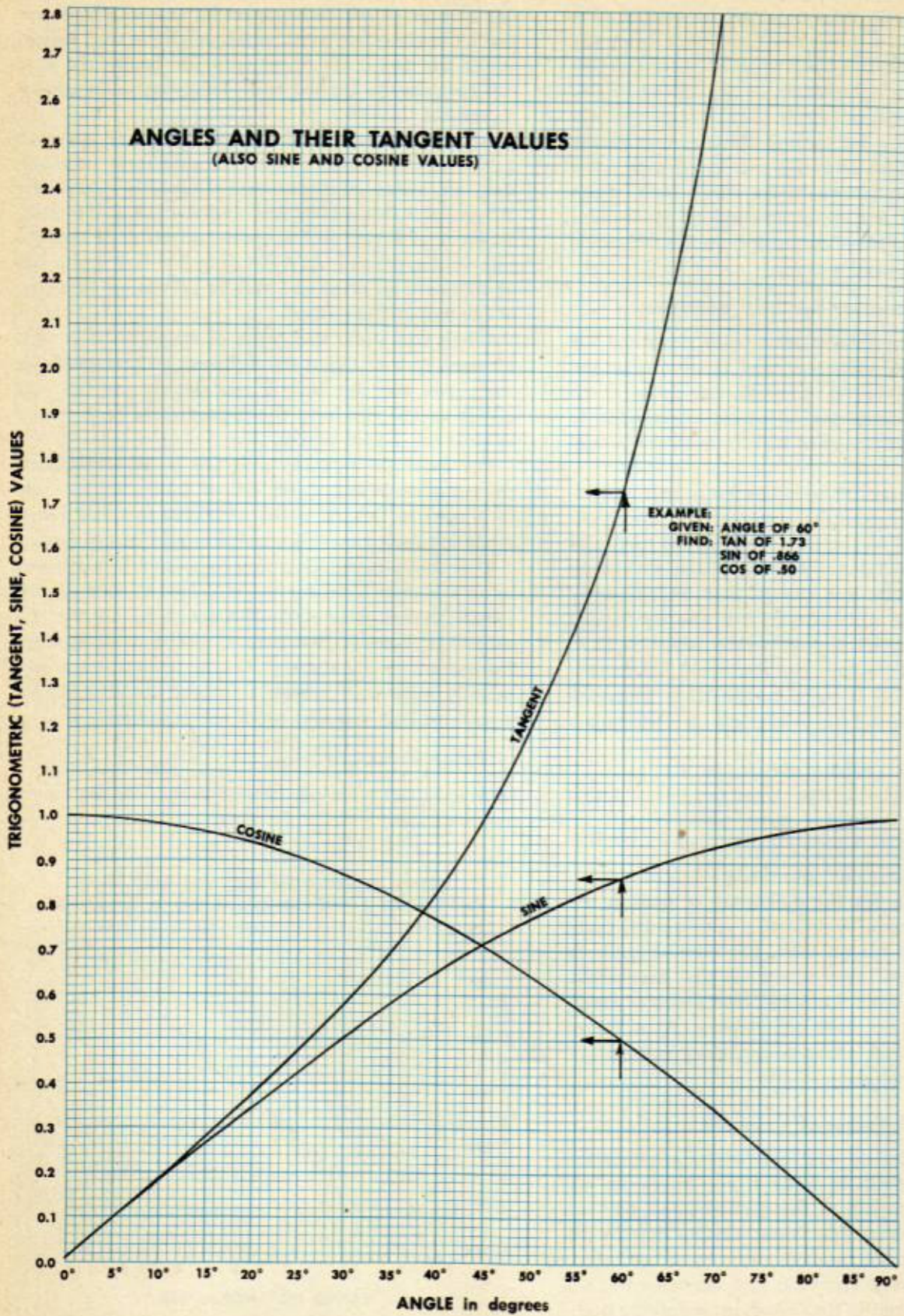

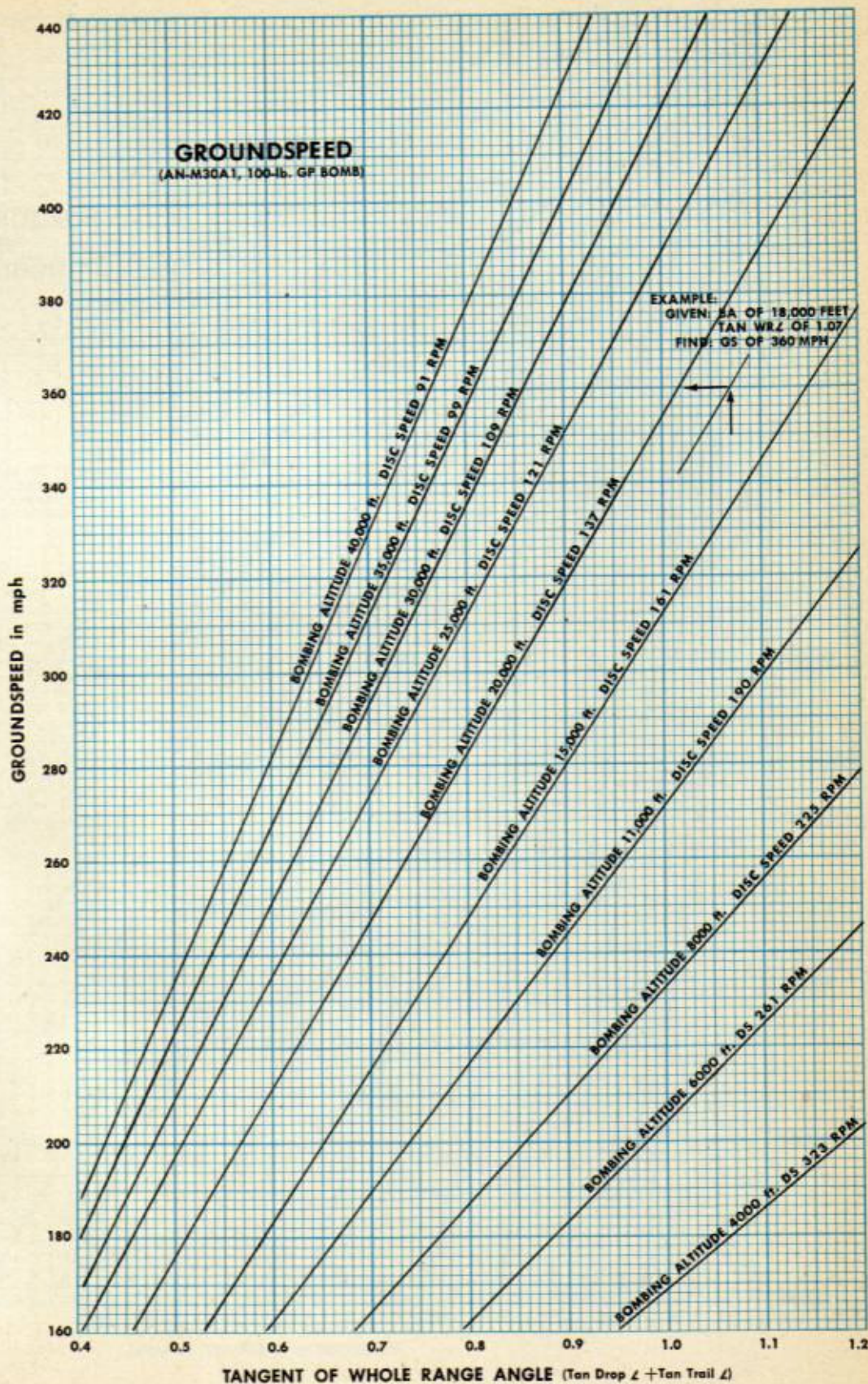

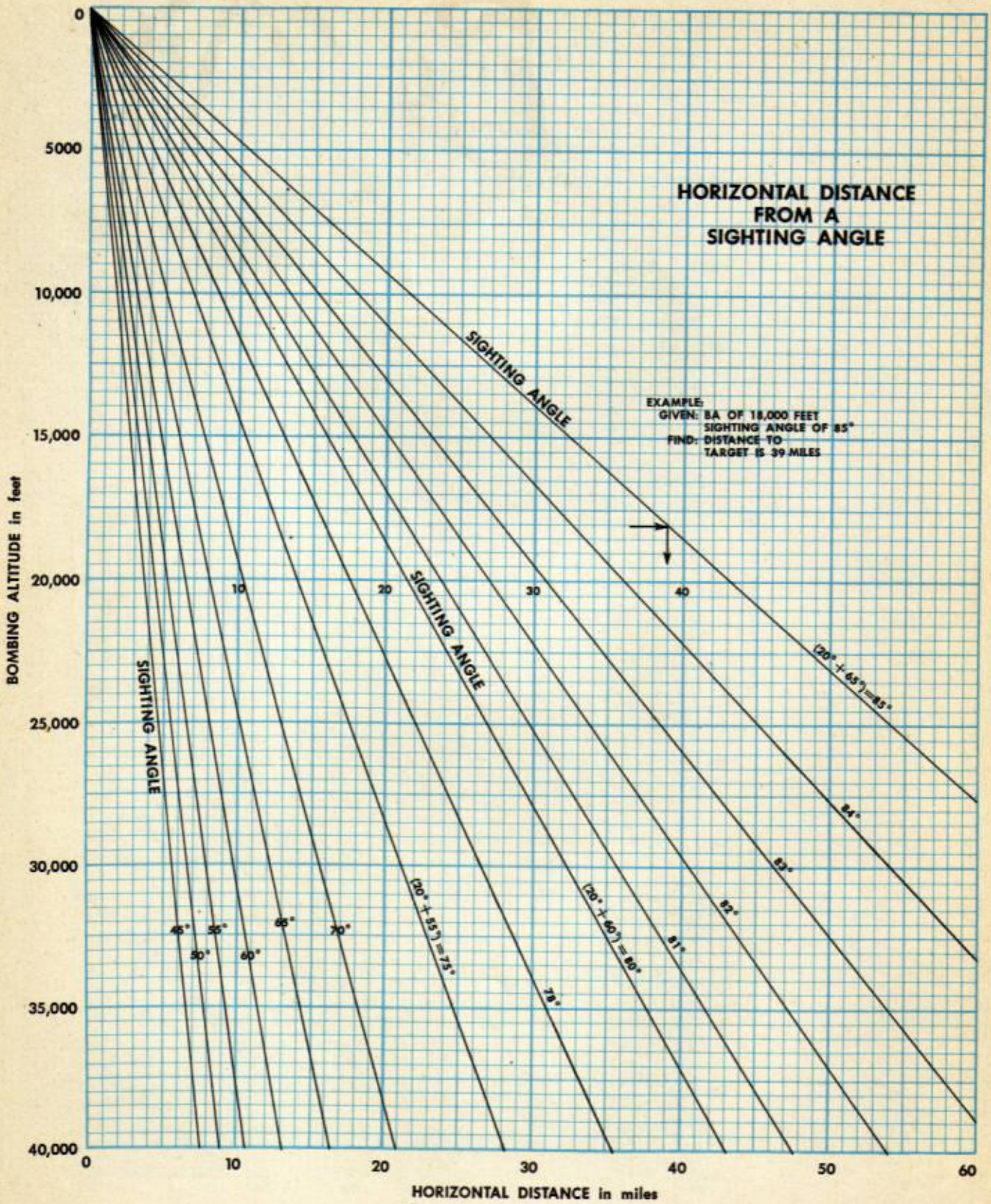



SECTION

3

COMPUTERS . . .

You have to make many calculations and you have to make them in a hurry. Computers, if you know how to use them, can solve your problems accurately, and they can do it quickly and easily.

The E-6B computer is so designed that you can use it for nearly all of your computations in navigation and bombing. However, there are other computers which supplement it and do special problems with equal and sometimes greater accuracy.

The AB computer, which is used with the M-series bombsight, enables you to solve for wind and automatically indicates the drift angle and dropping angle for any heading of your airplane.

You use the C-2 computer or the AN computer to solve for your bombing altitude. The G-1 computer enables you to find your true airspeed. The J-1 computer gives you a sighting angle for a 30- or 45-second bombing run.

E-6B COMPUTER

The slide rule on the back of the E-6B computer has a stationary outer scale, and an identical movable inner scale on a rotating disc. In your calculations, the outer scale usually represents units of measure (miles, gallons) while the inner scale represents units of time (hours and minutes). However, since these scales are standard logarithmic scales you can use them to solve any problem in multiplication or division.

On either scale, the numbering starts from the Index 10 and reads **clockwise** around the circle to 10 again, which is now equivalent to 100 (10×10). Thus, each time around the scale, the values increase in multiples of 10. You can use them to represent any desired number, large or small.

The subdivisions around the scale are not of equal value. Usually when a bombardier says his computer has given him the wrong answer, it is because he has misread the value of the subdivisions. Here is the way the computer is subdivided. From 10 around to 15, each subdivision represents 1 unit. From 15 to 30, each subdivision represents 2 units. From 30 to 60, each subdivision represents 5 units; from 60 to 100 10 , each subdivision represents 10 units.

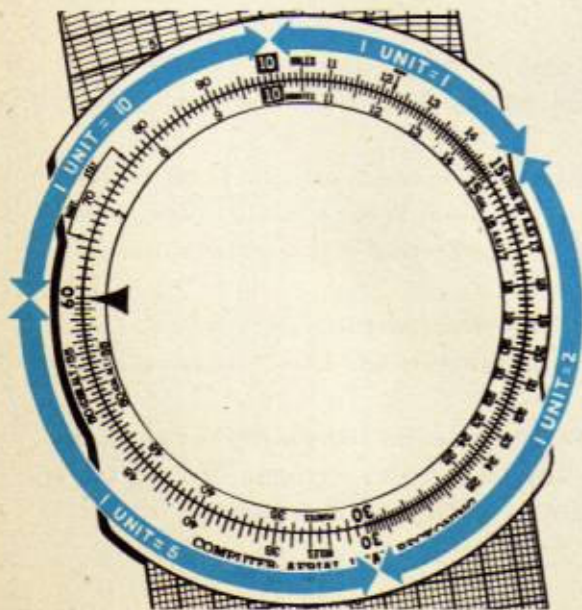

Multiplication. On the E-6B computer you multiply numbers by adding their logarithmic distances. Example: $12 \times 15 = 180$.

Set 10 on inner scale opposite 12 on outer scale and opposite 15 on inner scale read 180 (18) on outer scale. In so doing you add the logarithmic distance of 12 (a) to the logarithmic distance of 15 (b) to obtain the logarithmic distance of 180 (c).

Thus: $a + b = c$.

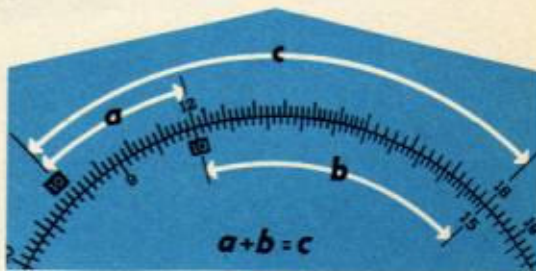

Division. You divide numbers by subtracting their logarithmic distances. Example: $180/15 = 12$.

Set 15 on inner scale opposite 180 on outer scale and opposite 10 on inner scale read 12 on outer scale. In so doing you subtract the logarithmic distance of 15 (b) from the logarithmic distance of 180 (c) and obtain the logarithmic distance of 12 (a).

Thus: $c - b = a$.

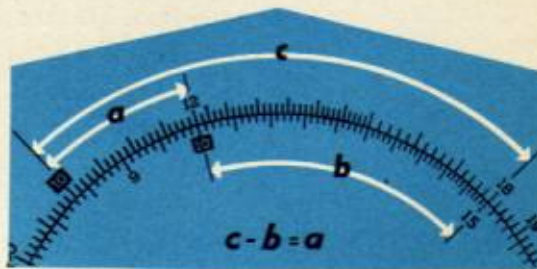

Proportion

Since 60 mph equals 88 ft/sec you can convert mph to ft/sec by setting 60 on inner scale opposite 88 on outer scale or by setting the equivalent proportion, 3600 opposite 5280. Then, opposite any **speed**

in mph on inner scale you can read the same speed in ft/sec on outer scale, and vice versa. For example, a speed of 120 ft/sec equals 82 mph.

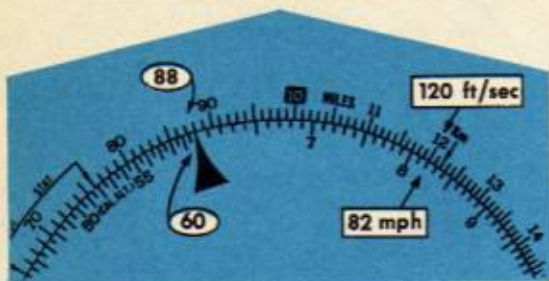

When you set a distance in nautical miles at the NAUT marker, the equivalent distance in statute miles and kilometers appears at their respective markers, and vice versa. For example, a distance of 100 nautical miles is the same as 115 statute miles or 185 kilometers.

You can solve all such problems of proportion on the circular slide rule.

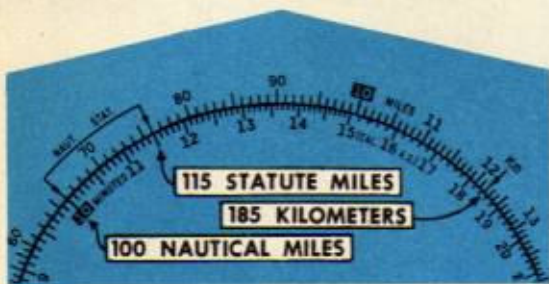

Distance, Time and Speed

You use the black pointer of the inner (time) scale in all problems involving time. This constitutes 1 hour of time or 60 minutes.

There is a definite relationship between distance, time, and speed. Distance is the product when time is multiplied by speed. Speed is the quotient when distance is divided by time. Time is the quotient of distance divided by speed.

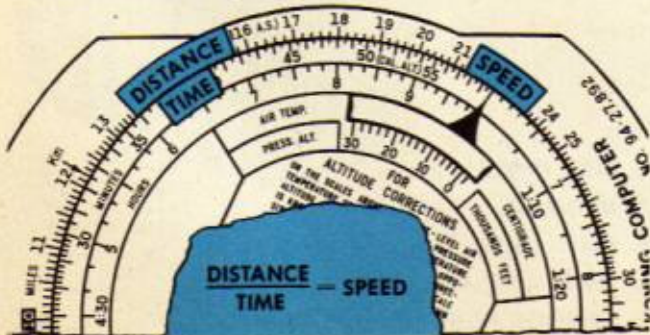

Therefore, always place distance on outer scale opposite time in hours or minutes on inner scale. This divides distance by time. Then read speed on outer scale opposite black pointer.

These positions are always the same, regardless of which item is unknown. If you set two knowns on computer in their proper places, you can find the unknown at its proper place.

Fuel Consumption

You calculate fuel consumption problems in the same manner as distance, time, and speed. The only difference in the problem is that you substitute gallons of fuel for units of distance; therefore, find the rate of consumption at the black pointer.

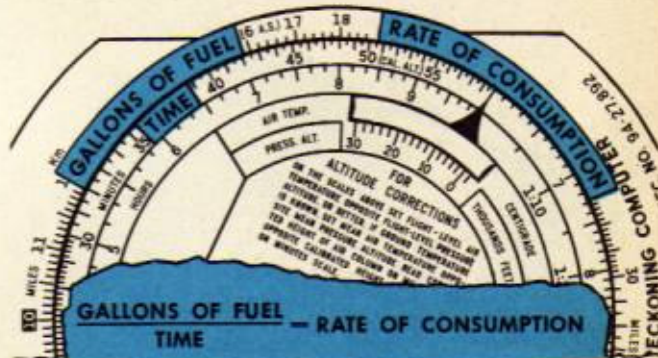

True Altitude

When you use the E-6B to compute your true altitude for navigation, always be sure to use the window marked FOR ALTITUDE CORRECTION.

Adjust rotating disc to bring flight level pressure altitude opposite flight level air temperature in altitude correction window.

Opposite flight level pressure altitude on inner scale, find true altitude above sea level on outer.

Subtract ground elevation from true altitude to find absolute altitude.

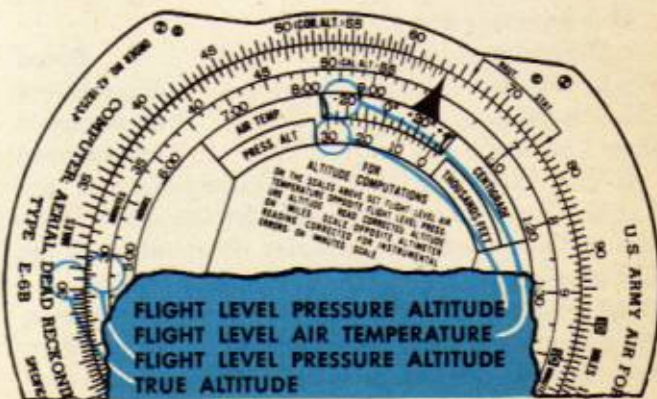

True Airspeed

When you use the E-6B computer to find your true airspeed, always be sure to use the window marked FOR AIRSPEED CORRECTION.

Adjust rotating disc to bring flight level air temperature opposite flight level pressure altitude in airspeed correction window.

Opposite calibrated airspeed on inner scale, find true airspeed on outer scale; or

When true airspeed is known, opposite true airspeed on outer scale find calibrated airspeed on inner scale.

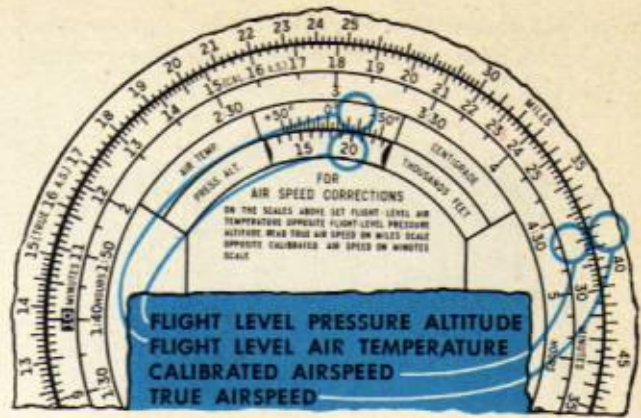

VECTOR SOLUTIONS

The front side of the E-6B computer consists of the transparent plotting disc, the sliding chart, and the drift-and-variation scale. This side is used to solve wind vectors and similar problems without plotting the complete triangles. Otherwise you solve vector problems exactly as you would if plotting them on graph paper. Each of the 3 sides of the triangle is called a vector and represents a direction and speed.

The 3 vectors are:

Direction	Speed
Wind Direction	Wind Speed
True Heading	True Airspeed
True Course	Groundspeed

If you know any 2 of the 3 directions and any 2 of the 3 speeds you may solve for the other direction and speed on the computer. Remember, in the vector triangle:

- Wind direction and wind speed always go together.
- True heading and true airspeed always go together.
- True course and groundspeed always go together.

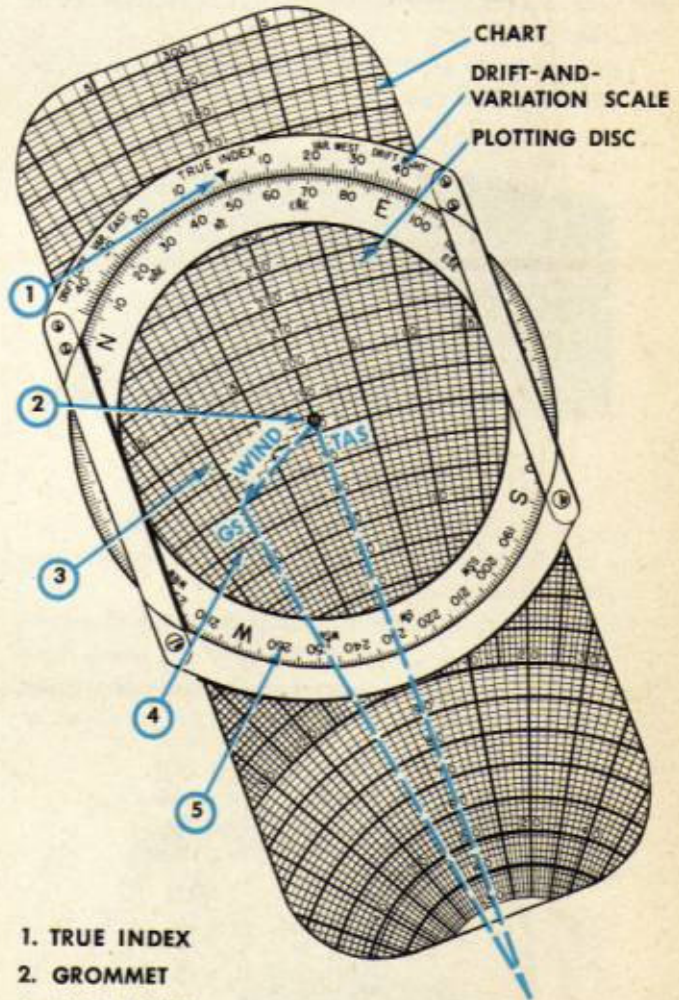

1. TRUE INDEX
2. GROMMET
3. DRIFT LINES
4. SPEED CIRCLES
5. COMPASS ROSE

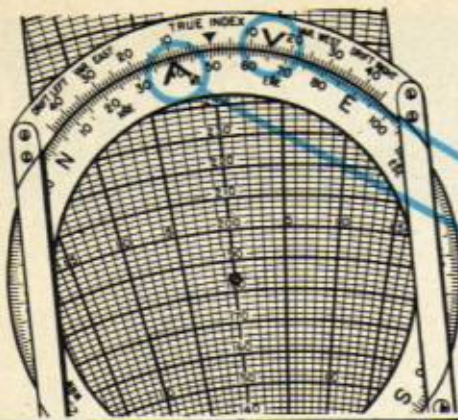

Mark magnetic index on drift-and-variation scale at local variation, with **V**.
 Mark true course on compass rose with **A**.

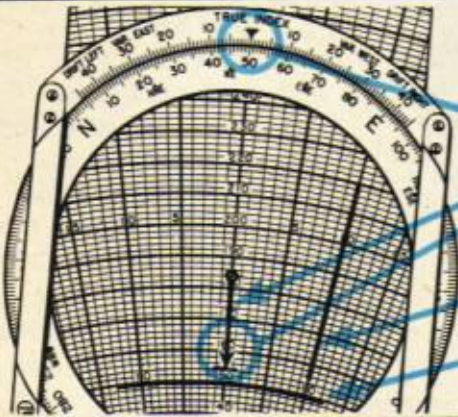

Plot **wind arrow** on plotting disc by setting wind direction at true index and tracing measurement of wind speed from grommet down centerline of chart. Then, mark end with short crosswise line and/or point.
 Plot **drift** on plotting disc by tracing along appropriate radiating drift line.
 Plot **groundspeed** on plotting disc by tracing along arc of appropriate groundspeed circle.

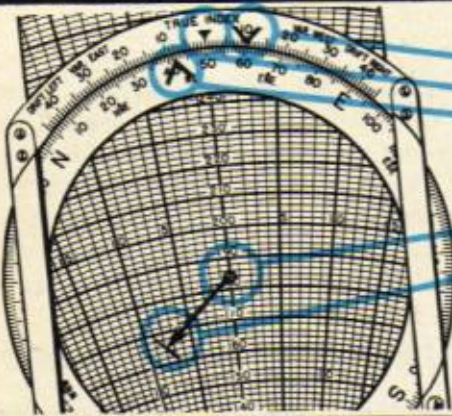

Set or find **magnetic heading** at magnetic index.
 Set or find **true heading** at true index.
 Set or find **true course** on compass rose at drift correction on drift-and-variation scale.
 Set or find **true airspeed** under grommet.
 Set or find **groundspeed** at point of wind arrow.
 Set or find **wind direction** at true index, when wind arrow points down centerline of charts. (This is direction from which wind is blowing.)

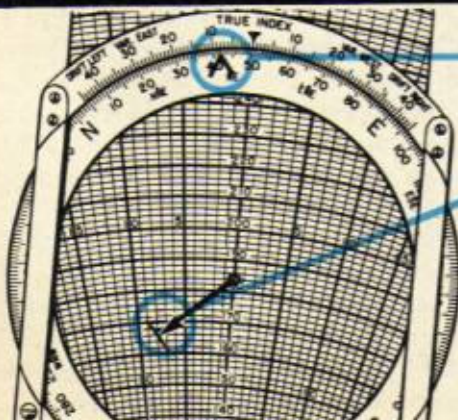

Find **drift correction** on drift-and-variation scale opposite true course.
 Find **drift** at point of wind arrow.
 Find **wind speed** by measuring from grommet down centerline of chart to point of wind arrow.
Note: When 3 drift lines intersect, or form a small triangle, you can be reasonably sure that you have an accurate wind solution.
 When you solve for true course properly, your TC is at your drift on drift-and-variation scale when point of arrow is at your drift on drift lines.

AUTOMATIC BOMBING COMPUTER

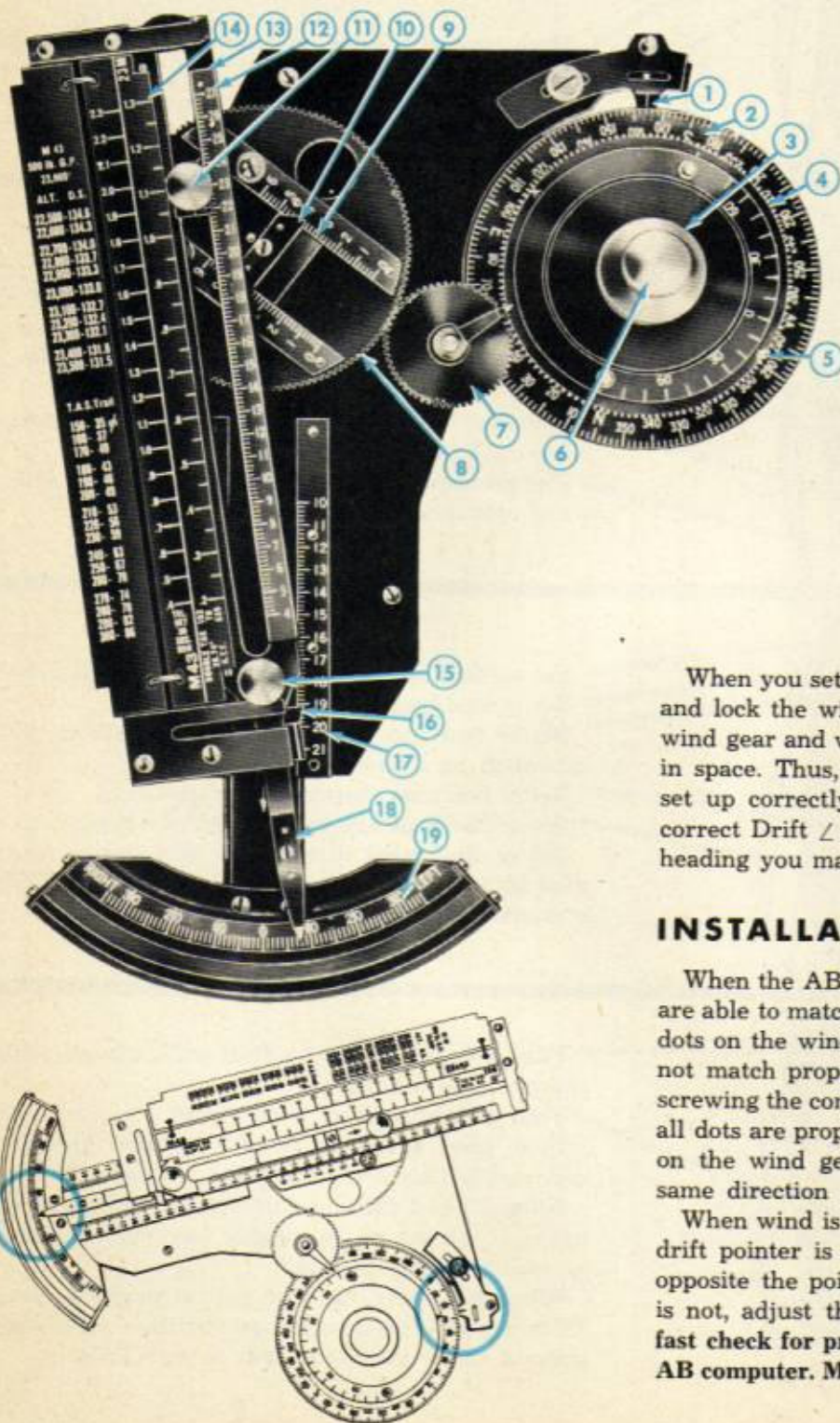

1. LUBBER LINE
2. COMPASS ROSE
3. COMPASS ROSE LOCK
4. WIND GEAR
5. WIND ARROW (tail)
6. WIND GEAR LOCK
7. IDLER GEAR
8. WIND DISC
9. WIND SPEED SCALE
10. WIND SPEED INDICATOR
11. WIND SPEED LOCK
12. GROUND SPEED SCALE
13. GROUND SPEED BAR
14. TANGENT SCALE
15. TRUE AIRSPEED LOCK
16. TRUE AIRSPEED INDICATOR
17. TRUE AIRSPEED SCALE
18. DRIFT POINTER
19. DRIFT SCALE

When you set TAS and wind on the AB computer and lock the wind gear to the directional gyro, the wind gear and wind disc are held in a fixed position in space. Thus, when the vector triangle has been set up correctly for one heading it gives you the correct Drift \angle and Tan Drop \angle to pre-set for any heading you may fly on your bombing run.

INSTALLATION AND ZEROING

When the AB computer is installed correctly, you are able to match the dots on the idler gear with the dots on the wind gear and wind disc. If the dots do not match properly, remove the wind gear by unscrewing the compass rose lock and replace it so that all dots are properly matched. Then the wind arrow on the wind gear is parallel to and points in the same direction as the arrow on the wind disc.

When wind is set on the wind speed scale and the drift pointer is set at 0° , the lubber line must be opposite the point or tail of the wind arrow. If it is not, adjust the lubber line until it is. This is a fast check for proper installation and zeroing of the AB computer. Make it before each mission.

WIND

You can obtain wind direction and speed from metro predictions, drift measurements, or drift and groundspeed measurements. Such metro winds and winds found with the use of the E-6B computer are always from true north. Winds set on the AB computer must always be from magnetic north. Therefore, when you set them on this computer you must apply local variation to metro winds and winds found on the E-6B computer.

Subtract east variation from the true direction of the wind to find its magnetic direction. For example: $315^\circ \text{ True} - 11^\circ \text{ E Var.} = 304^\circ \text{ Mag.}$

Add west variation to the true direction of the wind to find its magnetic direction. For example: $140^\circ \text{ True} + 14^\circ \text{ W Var.} = 154^\circ \text{ Mag.}$

To Set Known Wind on AB Computer

1. Rotate wind gear until tail of wind arrow is at magnetic direction of wind on compass rose, and
2. Lock wind gear to compass rose with wind gear lock.
3. Set wind speed on wind speed scale, and
4. Lock wind speed lock.

You can use the bombsight to find the Drift \angle and Tan Drop \angle for the heading, airspeed, and altitude the airplane is flying. You can then find the magnetic direction and speed of the wind by setting this Drift \angle , Tan Drop \angle , magnetic heading (MH), and TAS on the AB computer.

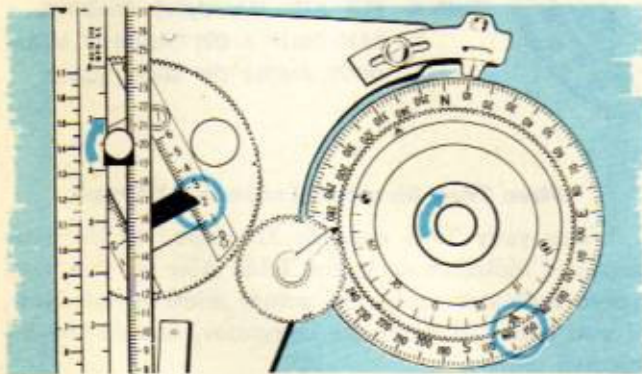

To Find Wind Using Bombsight and AB Computer

1. Airplane is flown manually or by autopilot on any constant heading, at height above the ground equal to BA, and at airspeed at which you will make your bombing run.
2. Set proper trail, DS, and small Sight \angle into bombsight.

3. Uncage gyro and swing bombsight as driftmeter to determine Drift \angle .

4. Synchronize for rate to find Tan Drop \angle .

5. Attach tangent scale to AB computer for BA, TAS, and type of bomb.

6. Loosen all 4 locks.

7. Set and lock TAS on true airspeed scale.

8. Set and lock MH on compass rose under lubber line.

9. Turn wind arrow to approximate direction of wind.

10. Set drift pointer at Drift \angle found from bombsight.

11. Hold drift pointer at Drift \angle and rotate wind gear to place groundspeed indicator at Tan Drop \angle found from bombsight.

12. Lock wind speed lock and wind gear lock.

You should complete this entire operation before turning off the heading on which you determined the wind.

The magnetic direction and speed of the wind are now set on the AB computer. You find the magnetic direction of the wind at the tail of the wind arrow. You find the wind speed at indicator on the wind speed scale.

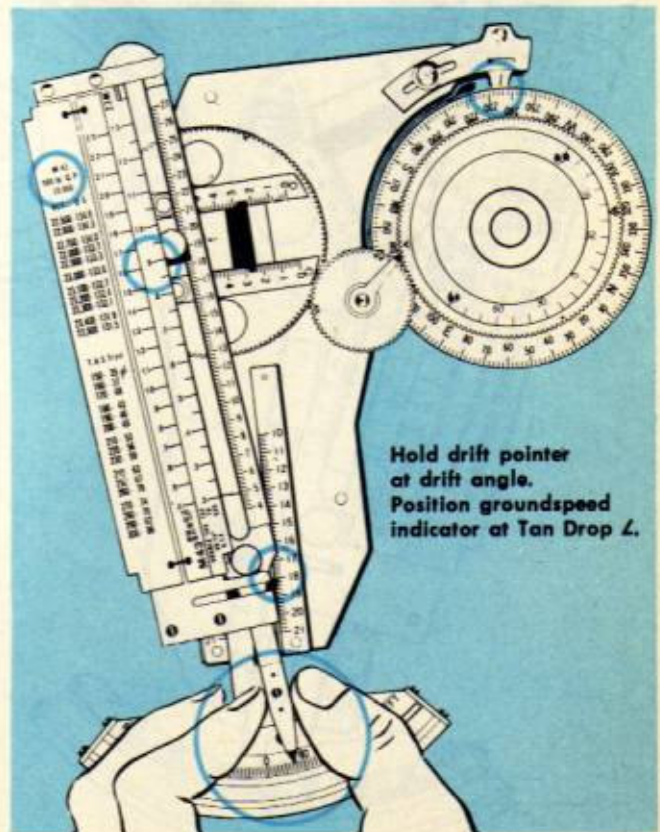

OPERATION

When you have determined the wind direction and speed, and know them to be accurate, set your data into the AB computer and use it as follows:

To set up the AB computer:

1. Attach proper tangent scale for BA, TAS, and type of bomb.
2. Set and lock TAS on true airspeed scale.
3. Set and lock magnetic direction and speed of wind on computer.
4. Set and lock MH of airplane on compass rose under lubber line.

Now, for any MH of the airplane:

1. Find Tan Drop \angle and GS at groundspeed indicator, and
2. Find Drift \angle at drift pointer.
3. Note wind arrow indicates wind direction at all times. This is helpful in planning evasive action and bombing run.

To find information on MH other than that which airplane is flying:

1. Loosen compass rose lock, and set desired MH on compass rose under lubber line.
2. Read Drift \angle and Tan Drop \angle or GS.
3. Then set MH of airplane on compass rose under lubber line and lock again.

Correction for Precession

The directional gyro precesses about 10° for every 360° turn in the same direction. This causes the MH indicated on the compass rose of the AB computer to be incorrect. Thus, unless you make an adjustment, the AB computer indicates incorrect Drift \angle and Tan Drop \angle for the MH of the airplane.

To correct for this precession, first loosen compass rose lock. Then set the MH of the airplane on compass rose under lubber line and lock again. Do this shortly before making turn over IP and, if time permits, check again before starting bombing run.

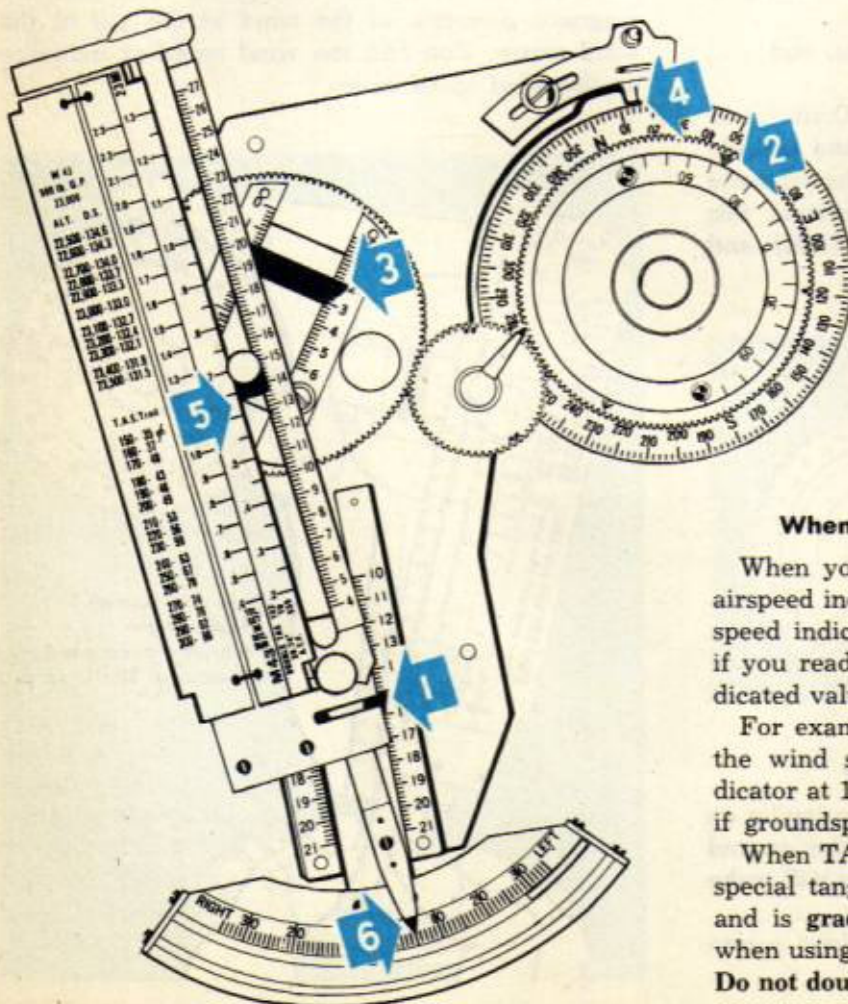

- SET: 1. TAS ON TRUE AIRSPEED SCALE
 2. MAGNETIC DIRECTION OF WIND
 3. SPEED OF WIND
- FIND: 4. FOR ANY MAGNETIC HEADING
 5. TAN DROP \angle ON TANGENT SCALE
 6. DRIFT ANGLE ON DRIFT SCALE

When True Airspeed Exceeds 210 mph

When your TAS exceeds 210 mph, set the true airspeed indicator at $\frac{1}{2}$ the TAS. Also set the wind speed indicator at $\frac{1}{2}$ the actual wind speed. Now, if you read GS from the computer, double the indicated values.

For example: Suppose your TAS is 300 mph and the wind speed is 40 mph. Set true airspeed indicator at 150. Set wind speed indicator at 20. Then, if groundspeed indicator is at 135, GS is 270 mph.

When TAS is more than 210 mph you must use a special tangent scale. It is marked DOUBLE TAS and is graduated to give correct tangent readings when using $\frac{1}{2}$ settings of TAS, wind speed, and GS. Do not double tangent values given on this scale.

BOMBING ALTITUDE COMPUTATIONS



You cannot bomb accurately unless you know your exact bombing altitude (BA). It is comparatively easy to find if you know how to use your altimeter and temperature gage indications, available meteorological information, and your C-2, AN, or E-6B computer.

Altimeter

The altimeter in your bombing airplane is an aneroid barometer. It is designed to indicate the true altitude above sea level, with the pressure scale set at 29.92, only if you are flying in U.S. standard atmospheric conditions. These conditions exist only when the standard datum plane (the level where barometric pressure of 29.92 exists) is at sea level; when the air temperature at sea level is 15°C (standard sea level temperature), and when the air temperature decreases 2°C for each 1000 feet increase in altitude (standard lapse rate). These conditions comprise a convenient yardstick. In actual practice, you rarely if ever encounter them.

The barometric pressure changes throughout each day and varies at different locations on the surface of the earth and at sea level. These changes are usually gradual and the barometric pressure at sea level can be above or below the average or standard barometric pressure of 29.92. If you use the altimeter properly, you are not concerned with this barometric pressure so long as you know the target pressure altitude (TPA).

The temperature of the atmosphere also varies greatly with different seasons, locations, and levels. Since air expands as it grows warmer, when air temperature is above normal the indication of the altimeter at different levels in the atmosphere will be greater than normal. Therefore you must know the temperature of the air column between the target and flight level in order to correct the altimeter indication by the proper amount to obtain a true measurement of the air column.

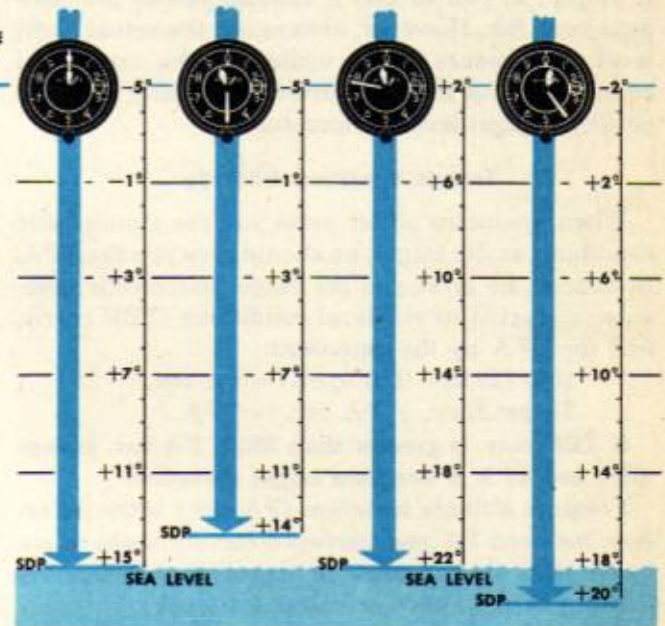

Effect of pressure and temperature changes on altimeter.

The barometric pressure and temperature of the atmosphere always vary from standard conditions. However, with the pressure scale at 29.92, the altimeter still indicates pressure altitude (PA) if it is properly calibrated. PA has a definite relationship to the true altitude. When you understand this relationship, you know why and how you must correct PA to find true altitude.

Temperature Gage

In taking temperature readings, you must remember that your temperature gage moves through the air at the true airspeed of the airplane. This rapid movement of air around the temperature gage, by producing compression and friction, causes a higher temperature indication than the actual air temperature. Therefore, you must correct each indication by **subtracting** the airspeed correction. You can find the correction for true airspeed compression error from the equation: $\text{correction} = -.00008 \times (\text{TAS})^2$. It is always negative, so **always decrease your temperature reading** by the amount of the correction.

Meteorological Information

Frequently your metro station can predict the atmospheric conditions at the target. Always obtain the predicted TPA, target temperature, and temperature aloft of the target whenever possible. This is the most accurate source of the TPA and target temperature. The predicted flight level temperature is helpful to you in that it enables you to pre-compute your BA. However, always use the actual flight level temperature in the vicinity of the target and recompute your BA if it varies appreciably from the predicted flight level temperature.

Target Pressure Altitude

When the metro officer gives you the atmospheric conditions at the target, he should give you the TPA. If, instead, he gives you the target barometric pressure, corrected to sea-level conditions (TBP corr.), find the TPA by the equations:

$$1000 (29.92 - \text{TBP corr.}) = \text{PA var.}$$

$$\text{Target Elev.} + \text{PA var.} = \text{TPA}$$

If TBP corr. is greater than 29.92, PA var. is negative and TPA is less than target elevation.

Pressure altitude variation (PA var.) is the difference between PA and surveyed elevation above sea level. It is the distance in feet that the standard datum plane is above or below sea level.

Often you can find TPA by comparing it to some known PA in the vicinity of the target. Here again the metro station should be able to assist you, by predicting the TPA on just that basis.

If you know the PA and the elevation of a level in the vicinity of the target, you can find the PA var. from their difference. For instance, assuming your runway to have comparable atmospheric conditions,

you would use the equation:

$$\text{RPA} - \text{Runway Elev.} = \text{PA var.}$$

$$\text{Thus, Target Elev.} + \text{PA var.} = \text{TPA}$$

Only when neither of the above is possible, you can assume the TPA equals the target elevation.

Target Temperature

From the metro station, find target temperature and the temperature at each 1000 feet of altitude above the target, or obtain them by comparison to some air temperature in the vicinity of the target. You can assume standard lapse rate or, better, local lapse rate to use with known air temperature to find target temperature.

If the target is higher, using the standard lapse rate, the target temperature is 2° lower for each 1000 feet difference in elevation.

Only when neither of the above is possible, you can assume that the target temperature is higher than your flight level temperature by the local lapse rate or the standard lapse rate of +2°C for each 1000 feet difference in altitude.

Pressure Altitude above Target

Always set pressure scale at 29.92 so that altimeter will indicate PA. Subtract TPA from FLPA to find PA above target. You correct this for existing pressure and temperature of air column to find BA.

Mean Temperature

To find the mean temperature of the air column add the temperatures at each 1000 feet between the target and flight level and divide their sum by the number of temperatures used.

When this is not possible, add the flight level temperature to the target temperature and divide by 2.

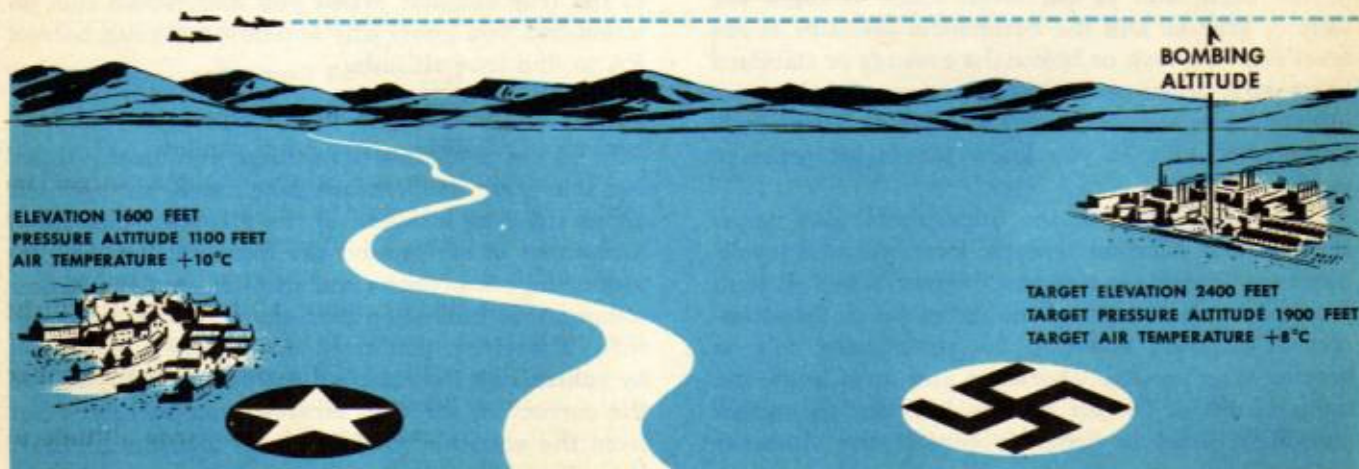

Friendly units in the vicinity of the target often can report the atmospheric conditions at the target to you.

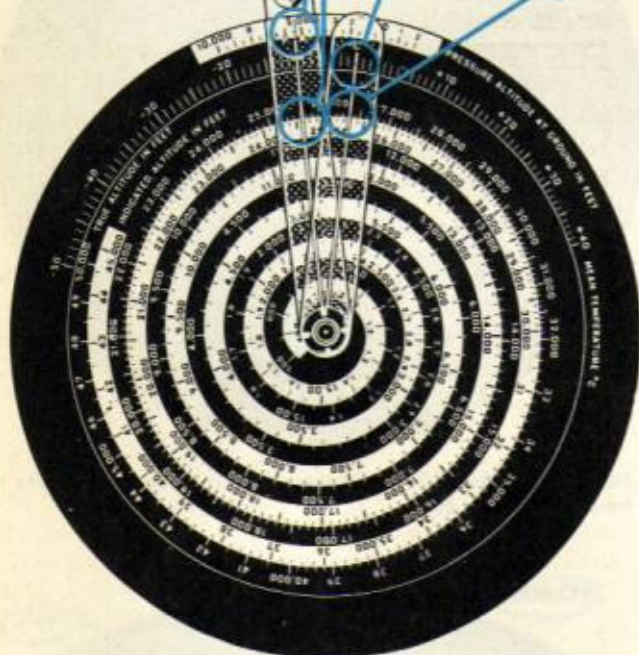
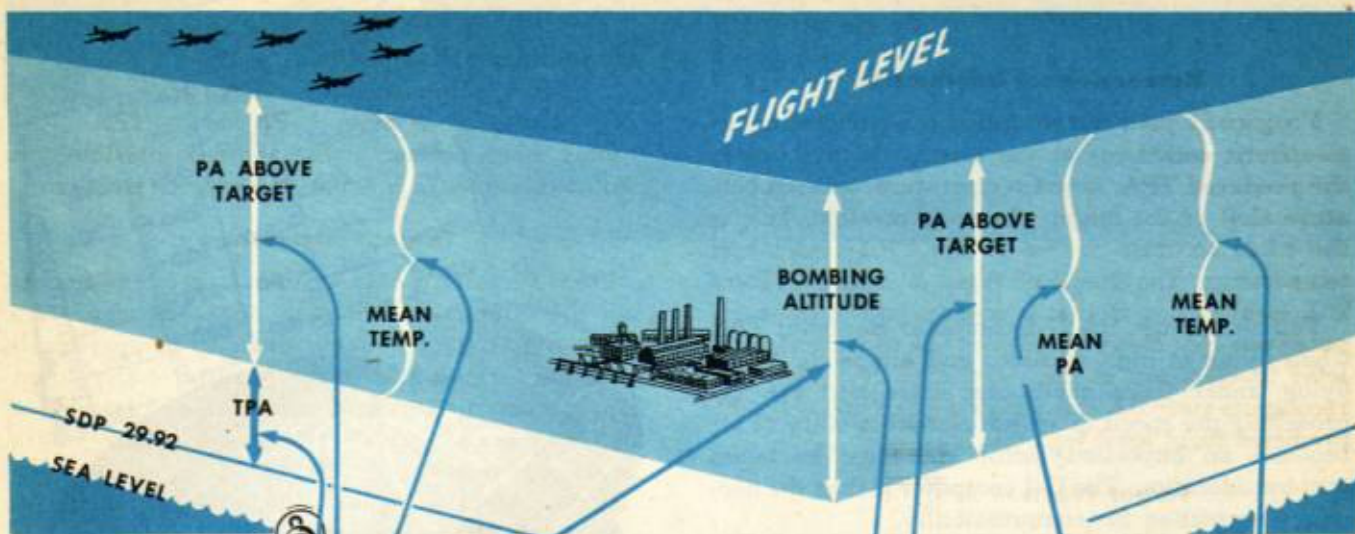

Using C-2 or AN Computer

1. Set clamped arm at target pressure altitude, and lock.
2. Rotate small disc until pressure altitude above target, in black figures, is under clamped arm.
3. Set free arm at mean temperature.
4. Under free arm find bombing altitude in light (or red) figures.

Mean Pressure Altitude

Find mean pressure altitude just as you find mean temperature. Add target pressure altitude to flight level pressure altitude and divide by 2.

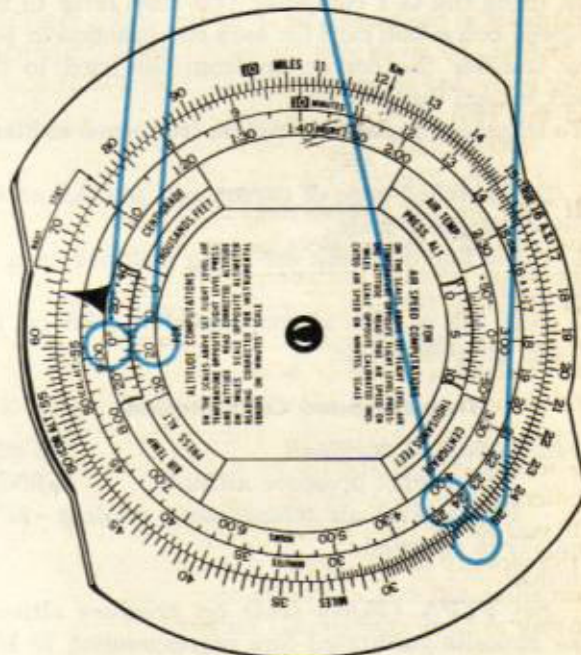

Using E-6B Computer

1. Set mean pressure altitude opposite mean temperature, in altitude correction window.
2. Opposite pressure altitude above target on inner scale, find bombing altitude on outer scale.
If you don't know TPA and target temperature, use E-6B as explained under correction window:
 1. Set flight level pressure altitude opposite flight level temperature in altitude correction window.
 2. Opposite flight level pressure altitude on inner scale, find true altitude above sea level on outer.
 3. Subtract target elevation from true altitude to find bombing altitude.

G-1 COMPUTER

You should use the G-1 computer to obtain TAS when flying at high altitudes and airspeeds. When flying under these conditions, since you are approaching the speed of sound, compressibility of air becomes an important factor and must be taken into consideration. The G-1 computer makes the necessary correction for compressibility.

In using the G-1 computer you may refer to the airspeed correction card for each computation or you may transfer the correction from the card to the blank arc on the computer.

To transfer airspeed correction from card to blank arc:

1. Set matched edge of cursor arm at CAS on indicated airspeed scale.
2. Draw line on blank arc along matched edge of cursor arm.
3. Join top of line to corresponding IAS on indicated airspeed scale.

True Airspeed Computations

Given: Indicated Airspeed 250 mph
 Flight level pressure altitude 35,000 ft.
 Flight level air temperature reading -32°C

Find: True airspeed.

Solution:

1. Set **FLPA** (35,000 feet) on pressure altitude scale opposite calibrated line corresponding to IAS (250 mph) on indicated airspeed scale.
2. Set cursor arm indicator at **flight level air temperature reading** (-32°C) on temperature scale.
3. Under cursor arm indicator read **approximate TAS** (457 mph) on true airspeed scale.
4. Find **airspeed correction** (-17°C) for 457 mph TAS from card or equation:

$$\text{Correction} = -.00008 \times (\text{TAS})^2.$$
5. Add **airspeed correction** (-17°C) to **flight level air temperature reading** (-32°C) to obtain **flight level air temperature** (-49°C).
6. Set cursor arm indicator at **flight level air temperature** (-49°C) on temperature scale.
7. Under cursor arm indicator read **correct TAS** (442 mph) on true airspeed scale.

1943 Airtel No. 45-127

Vc M P H	AIRSPEED READING	Vc KNOTS	Match to Compress Card Hold
270	250	320	AIRSPEED READING
260	240	310	
250	230	300	
240	220	290	
230	210	280	
220	200	270	
210	190	260	
200	180	250	

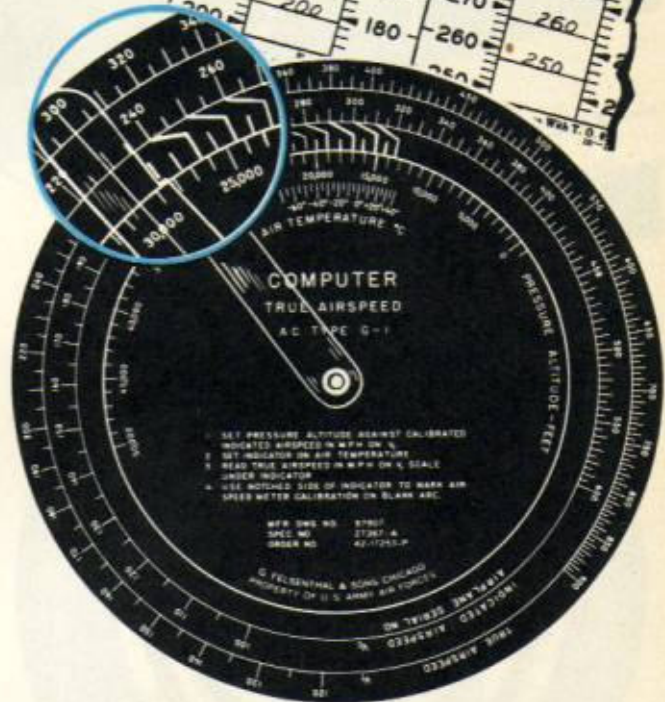

Mark blank arc of G-1 computer with airspeed corrections from calibration card.

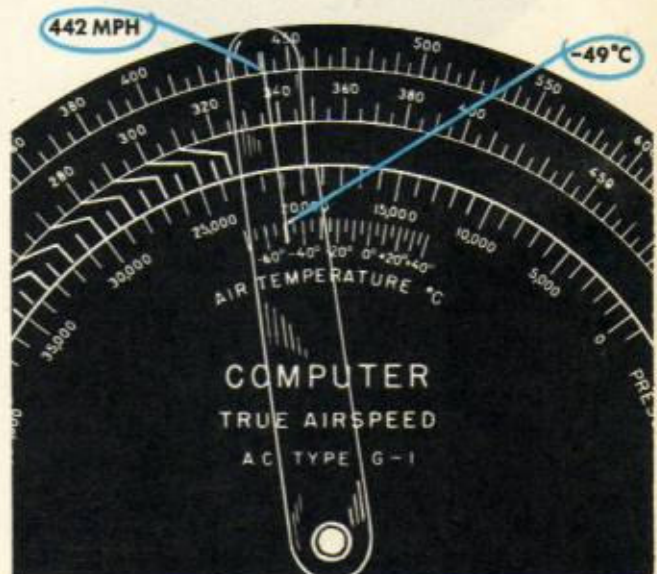

TIME-OF-RUN COMPUTATIONS

You determine the time of run and locate the starting point (Sight \angle) for a short bombing run mainly by reference to the Drop \angle you expect to have. There are 4 ways to find the Sight \angle :

1. Use J-1 sighting angle computer.
2. Solve simple equation.
3. Make trial and error timing of sighting angle index.
4. Make fast mental calculations. Experience will enable you to do this.

Using J-1 Sighting Angle Computer

To find the Sight \angle for a 30-second or 45-second bombing run with the J-1 computer, use the disc speed set into the bombsight and the Drop \angle you expect to have on the bombing run.

Given: Tan Drop $\angle = .70$.

Disc speed = 137 rpm.

Find: (A) Sight \angle for 30-sec. bombing run.

(B) Sight \angle for 45-sec. bombing run.



Solution (A)

1. Use side of computer marked 30.
2. Set disc speed (137) opposite Tan Drop \angle (.70).
3. At arrow read Sight \angle (52°).



Solution (B)

1. Use side of computer marked 45.
2. Set disc speed (137) opposite Tan Drop \angle (.70).
3. At arrow read Sight \angle (57.5°).

Using Sighting Angle Equation

You also can calculate the Sight \angle from the equation:

$$\text{Tan Sight } \angle = \text{Tan Drop } \angle + \frac{\text{Tan WR } \angle}{\text{ATF}} \times \text{Time of Run}$$

With this equation you can find the Sight \angle for any time of run.

Given: Tan Drop $\angle = .68$
 Trail = 98 mils
 ATF = 39 secs.

Find: Sight \angle for 60-sec. bombing run.

Solution:

1. $\text{Tan WR } \angle = .68 + .098 = .778$.
2. $\frac{\text{Tan WR } \angle}{\text{ATF}} \times \text{Time of Run} = \frac{.78}{39} \times 60 = 1.2$
3. $\text{Tan Sight } \angle = .68 + 1.2 = 1.88$ or 1.9

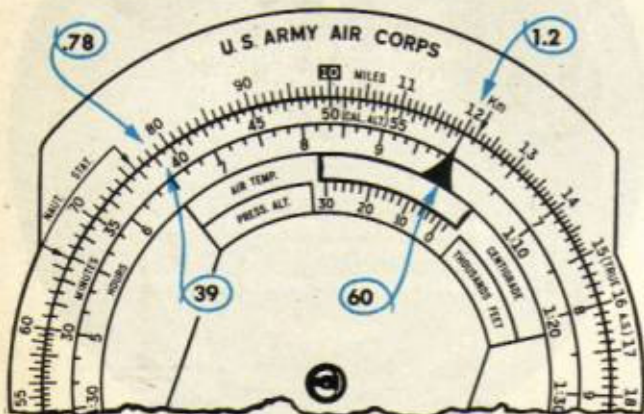

Using Fast Calculations

You also can find the Tan Sight \angle at any BA and for any desired time of run by multiplying the Tan Drop \angle by a factor, such as 2, 1.9, 2.6, which you have previously determined.

Given: Tan Drop $\angle = .50$
 BA = 17,000 ft.
 TAS = 316 mph
 Bomb = AN-M64A1, 500-lb. GP

Find: Sight \angle for 45-sec. bombing run.

- Solution: 1. Before mission, find factor (2.5) for 45-sec. bombing run, for given BA, TAS, and type of bomb.
2. $\text{Tan Sight } \angle = .50 \times 2.5 = 1.25$ or 1.2 .

To find factor for BA, TAS, and type of bomb to be used, prior to mission, use this equation:

$$\text{Factor} = 1 + \frac{\text{GS (ft/sec)} \times \text{Time of Run}}{[\text{GS (ft/sec)} \times \text{ATF}] - \text{Trail (ft)}}$$

By using TAS and GS in this equation you can work out a small table of any desired time of run for the particular BA, TAS, and type of bomb which you are most likely to use.

Using Trial and Error Timing

With experience and practice you should be able to determine what position of the sighting angle index will give the desired time of run. By trial and error you can arrive at the proper position quite readily.

Given: Tan Drop $\angle = .50$
 Trail = 90 mils
 ATF = 35 secs.

Find: Sight \angle for 50-sec. bombing run.

- Solution: 1. Find tangent change of sighting angle index for 10 seconds of drive. In this example it is .17.
2. Tangent change in 50 seconds therefore will be $5 \times .17 = .85$.
 3. $\text{Tan Sight } \angle = .50 + .85 = 1.35$.





SECTION

4

INSTRUMENT CALIBRATION AND NAVIGATION...

The purpose of the bombing mission is to find the target, deliver the bombs with precision, and get home. The success of your mission may depend to a large degree on your ability to navigate by DR and pilotage and to use radio aids. An emergency may force you to take over the navigator's duties.

The accuracy of your navigation and bombing depends upon the accuracy of your computations. Your altitude, TAS, and course corrections for navigation and bombing are based upon readings taken from the free-air temperature gage, airspeed indicator, altimeter, compass, and bombsight or driftmeter. Accordingly your calculations can be no more accurate than the data taken from these instruments.

Aircraft instruments have scale or instrument errors and, more important, installation errors. When you calibrate an instrument you find the errors in its indication under specified conditions. You record the corrections for those errors on a convenient card. Then when you use the instrument you refer to the card and apply the corrections to the indicated reading.

FREE AIR TEMPERATURE GAGE

There are 2 types of free air temperature gages in common use.

The bimetallic gage has as its sensitive element a spiral composed of 2 strips of different metals welded together. Temperature changes have greater effect on one metal than the other, and so cause the spiral to coil or uncoil. This motion causes the pointer to move over the dial.

The sensitive element of the electric gage is a coil whose resistance increases as the coil is warmed. An electric current passes through the coil and indicator. Changes in temperature cause changes in the amount of current and thus in the position of the pointer. You can recognize this type of gage easily because it does not indicate temperature until the master switch has been turned on.

Calibration

To calibrate either of these gages for scale error you take a series of readings and compare them with the readings of a master thermometer. This work can best be done in an instrument shop where the sensitive element of the master thermometer and of the gage which is being calibrated can both be placed

in the same medium and readings taken throughout the range of the gage. In case no instrument shop is available you may take a master thermometer on a mission and check the readings of your gage. The sensitive element of the master thermometer should be placed in the airstream as nearly as possible like that of the gage being tested. When you have determined the amount of scale error, make out a scale correction card and place it in the holder beside the instrument.

Most free air temperature gages are subject to an installation error which you can determine by calculation. As the air strikes the sensitive element, heat is generated by compression and friction. As a result the temperature gage indicates a higher temperature than actually exists. Calculate the amount of this error for the TAS range of your airplane, and **subtract** it from the temperature gage indication when you take a temperature reading. Use this equation:

$$\text{Correction (degrees C)} = -0.0008 \times (\text{TAS})^2.$$

If your TAS is 200 mph the correction is -3.2° ; for a TAS of 400 mph the correction is -12.8° . In using this correction, take the value to the nearest whole degree only.

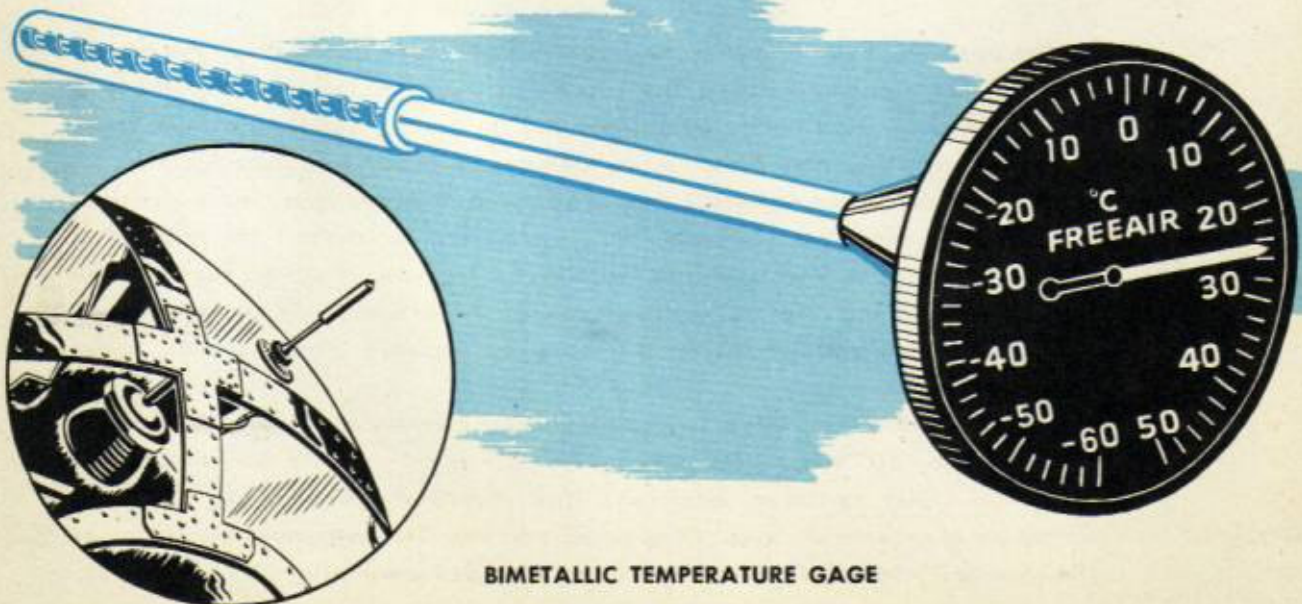

BIMETALLIC TEMPERATURE GAGE

PITOT-STATIC SYSTEM

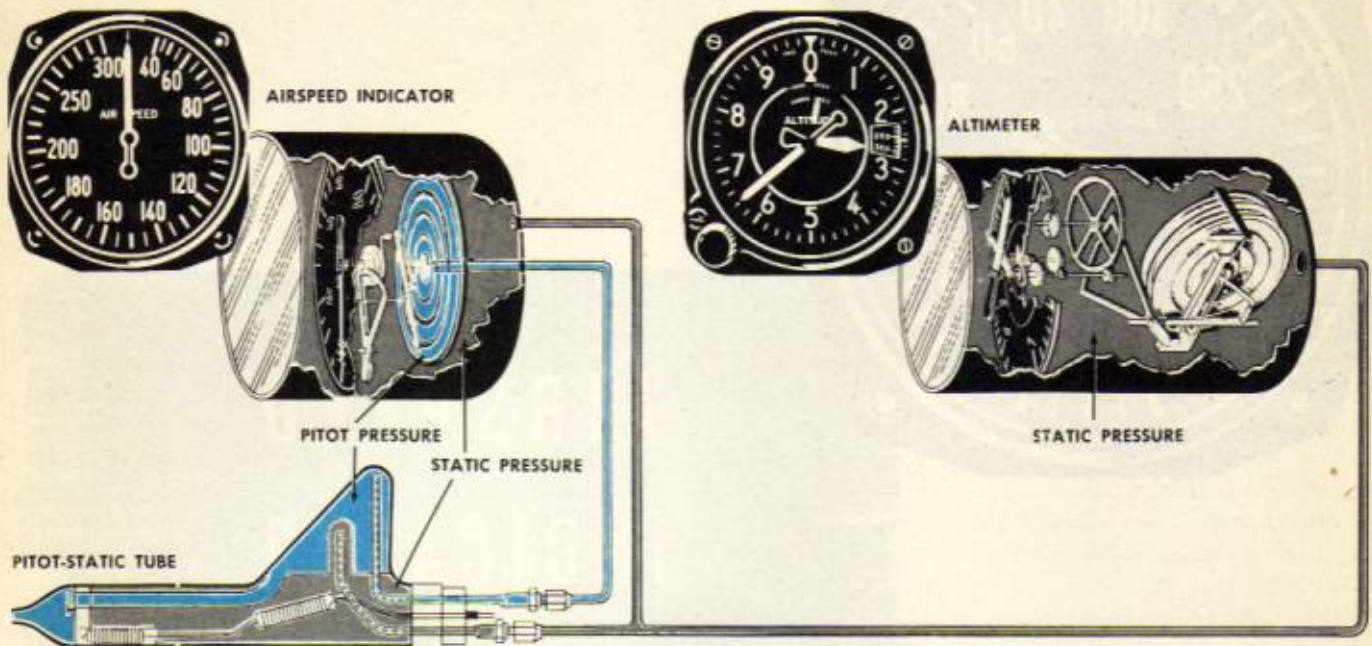

The pitot-static tube of the airplane projects into the airstream. The altimeter and the airspeed indicator are both connected to it. There are 2 compartments in the pitot-static tube. One of these compartments opens directly into the airstream. The pressure in this compartment is the sum of the static or normal barometric pressure and of the dynamic pressure caused by the motion of the airplane through the air. This total pressure is called **pitot pressure**. The openings into the other compartment are at right angles to the longitudinal axis of the tube and should not receive any dynamic pressure when the attitude of the airplane is normal. They should, however, receive the barometric or static pressure of the outside air.

Instruments that depend on the pitot-static tube are subject to installation errors resulting from static

pressure errors at different airspeeds and loads. These static pressure errors occur because the attitude of the airplane changes when the airspeed or load changes and because conditions of turbulence around the airplane are different at different airspeeds.

Total or pitot pressure received in the pitot compartment goes to the airspeed indicator. The static pressure received in the static compartment goes to the airspeed indicator and altimeter as well as to certain other instruments.

You should check the pitot-static tube frequently to make sure that it is not dented, clogged, bent, or out of alignment. Such defects cause large errors in your instruments. When your airspeed indicator or altimeter is not working properly, check for water or leaks in the connecting tubes.



ATTITUDE AFFECTS FLOW OF AIR AROUND TUBE



AIR SPEED INDICATOR

The mechanism of the airspeed indicator is in a sealed case. Static pressure received from the static compartment of the pitot-static tube enters the case through an opening in the back. The sensitive element is a small diaphragm or drum-like unit which contracts or expands when the pressure inside it changes. Changes in pressure in the diaphragm are translated to the face of the instrument by a series of gears and levers. The pressure inside the sensitive element is the pitot pressure received from the pitot-static tube.

Since the pressure surrounding the element is static pressure, and the pressure inside the element is pitot pressure, the difference represents dynamic pressure. It is this difference in pressure which the airspeed indicator registers and converts to an indicated reading in mph.

If there is a scale error in an airspeed indicator the instrument section finds it when the instrument is inspected and installed. The inspector writes a card showing any needed scale corrections and attaches it near the instrument.

The airspeed indicator is calibrated for installation errors by comparing its readings with correct airspeeds calculated from known groundspeeds. Accurate groundspeeds are obtained by timing the

flight of the airplane over a measured course or by using the bombsight. It is sometimes necessary to make separate calibrations with empty and loaded bomb bays. This is because when the airplane is loaded its attitude is different than when the bomb bays are empty.

Calibration with Measured Course

Calibration of the airspeed indicator by this method requires a course over practically level ground with an approximate length of 9 miles. The center section of about 5 miles length should lie between 2 parallel roads or other similar straight lines. There should be sufficient open space at each end of the course to permit the pilot to have a constant airspeed and altitude when he enters it.

1. Before takeoff, obtain accurate altimeter setting and set it on pressure scale of altimeter. If pointers do not then indicate surveyed elevation of field, adjust instrument as follows: Loosen screw in altimeter setting knob, pull knob out as far as it will come, and turn it until pointers indicate surveyed elevation of the field. Release knob and tighten screw. **Then set pressure scale at 29.92.**

2. Begin calibration by having pilot make run over course at low altitude and at IAS near top of

safe speed range of airplane. Heading must be perpendicular to roads that mark ends of course. **Pilot must not correct for drift.** Use stop watch to time run. Make another run at same altitude and IAS but on heading 180° from heading on first run.

3. Continue making pairs of runs on reciprocal headings, decreasing IAS from 10 to 15 mph on each pair. Do this throughout safe speed range of airplane.

4. On each run, record average IAS, pressure altitude (PA), temperature, and time to nearest tenth of second. Record data on AAF Form 21F, Calibration of Airspeed Indicator.

5. Calculate your GS on each run from equation:

$$\text{GS in mph} = \frac{3600 \times \text{length of course in miles}}{\text{time in seconds}}$$

Find TAS by averaging groundspeeds for each pair of runs.

6. With your E-6B computer, convert TAS to find calibrated airspeed (CAS) corresponding to each IAS.

7. Plot your values of CAS against IAS on graph paper. Use straight edge to draw straight line that will pass through the most points.

8. From graph select IAS readings in even 10-mile intervals and note corresponding CAS on AAF Form 21E. Fill in IAS readings opposite corresponding CAS readings. Sub-divide 10-mile interval into 5 equal spaces to facilitate reading.

9. Place calibration card in holder near instrument when completed.

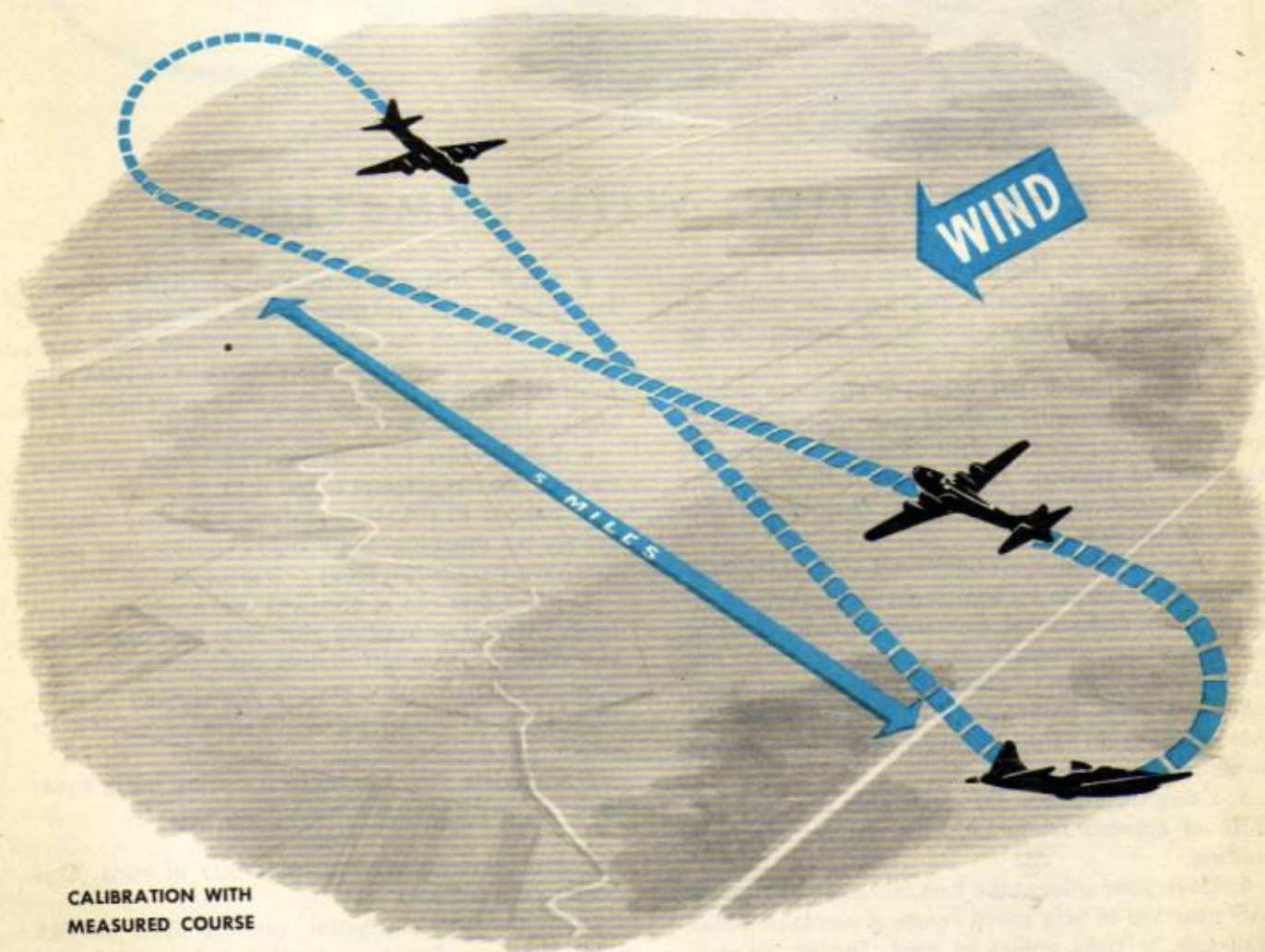

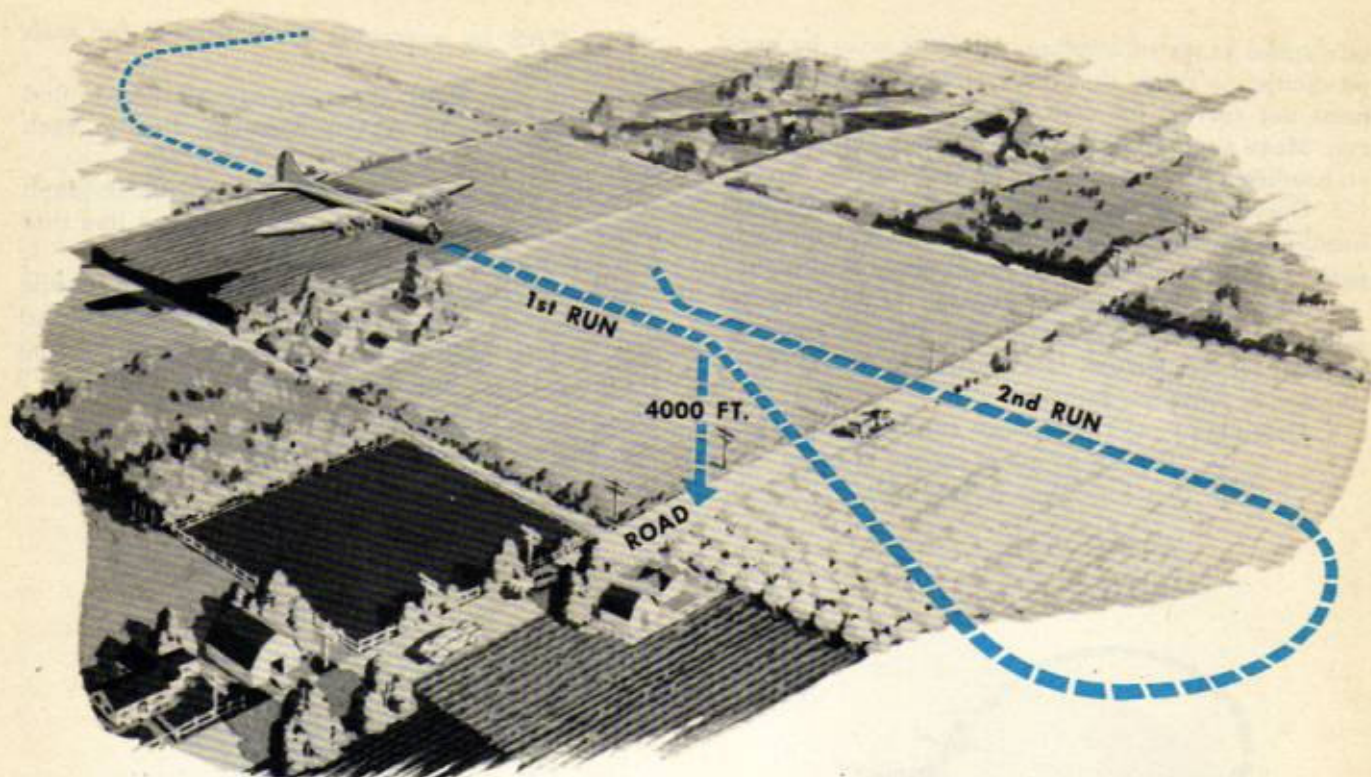

CALIBRATION WITH BOMBSIGHT

This method is similar to the measured course method. The difference is that here you solve for GS with the bombsight instead of getting GS by timing.

1. Before takeoff, get accurate altimeter setting and set it on pressure scale of your altimeter. Then make sure that indicated altitude is same as surveyed elevation of runway. If necessary adjust pointers until indicated reading is correct. **Then set 29.92 in pressure window.**

2. Select portion of straight road with known elevation. To calibrate by bombsight method you must know both flight level pressure altitude (FLPA) and BA, or actual height above road. Decide on one of these and compute other. BA of approximately 4000 feet gives convenient Tan WR \angle . Select BA that will provide FLPA in round figure, easy to read on altimeter.

3. Using tachometer, set in DS that provides Tan WR \angle of approximately 1.0. This reduces errors in reading.

4. Have your pilot make first run over road using IAS near top of safe speed range of airplane. Make approach at right angles to road. During all runs pilot must hold pre-determined PA, and on each run he must hold constant IAS.

5. Set 0° drift and 0 trail in bombsight. Engage bombsight clutch and align lateral crosshair on road. Keep it aligned throughout run, **using turn knob only.** From time crosshair has been put on road pilot must follow PDI, in order to make run on heading at right angles to road.

6. Synchronize for rate, keeping lateral crosshair on road. **Do not attempt to kill drift.**

7. Record FLPA, temperature, IAS, and tangent set up by dropping angle index. Notice that since you have 0 trail, Tan Drop \angle is same as Tan WR \angle .

8. After first run is complete make second run at same IAS but at heading 180° from first one. These two runs give you GS **against** wind and **with** wind. Continue to make pairs of runs, decreasing IAS from 10 to 15 mph for each pair until speed range of your airplane is covered.

9. Calculate your GS on each run by using equation:

$$GS \text{ (mph)} = \frac{DS \times BA}{7773} \times \text{Tan WR}\angle$$

Average groundspeeds on each pair of runs. This average GS is TAS.

10. With E-6B computer convert TAS to find CAS corresponding to each IAS. Draw graph and prepare calibration card in same manner as in measured course method.

ALTIMETER

The case of the altimeter is a sealed compartment which has only one opening. The static pressure received from the static chamber of the pitot-static tube enters through this opening. Therefore the pressure inside the altimeter case should always be the same as the barometric pressure of the air through which the airplane is flying. The sensitive element which registers changes in pressure is in this sealed case and consists of several diaphragms built together into a small drum-like unit. When variations in pressure occur the expansion or contraction of the diaphragm is translated through a series of gears and levers to the pointers on the indicating dial. These pointers move over a scale which is graduated in feet.

Scale errors in altimeters are usually determined by the factory or Sub-Depot shops. The proper corrections are then written on a card which is attached near the instrument.

Calibration with Alidade

The alidade (AAF Drawing 41D5098) is a simple sighting device which permits the use of 2 similar triangles to determine the exact height of an airplane when it is flying over some predetermined landmark. Proper calibration with the alidade determines the amount of static pressure correction needed. Usually a static pressure correction card is not filled out unless the correction is more than 25 feet.

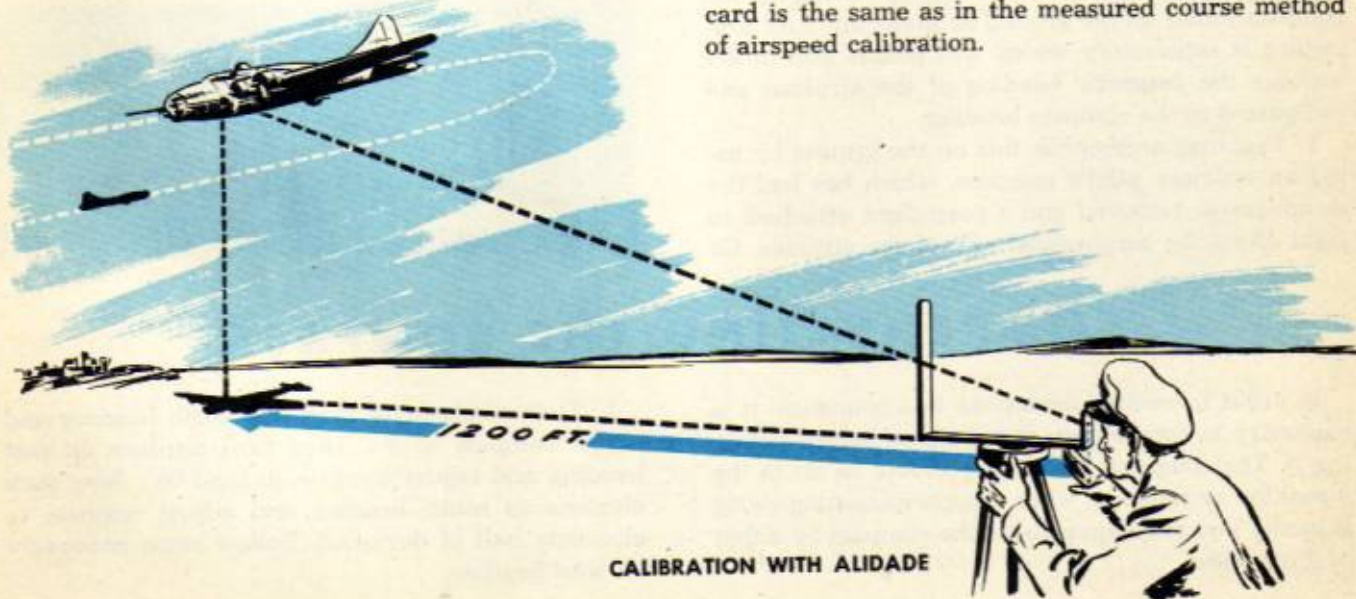

CALIBRATION WITH ALIDADE

1. Before takeoff, select level area, preferably near landing strip, and establish marker which you can easily see from air. Then set up alidade 1200 feet away. Taxi airplane as near alidade as possible and record PA.

2. Make series of runs over marker. First run should be made near top of safe speed range of airplane and airspeed for each successive run should be decreased from 10 to 15 mph.

3. Each time airplane passes over marker, ground observer records alidade reading and number of run. Observer in airplane records number of run, PA, and IAS.

The difference between the altitude measured by the alidade and that measured by the altimeter is the static pressure error.

4. Make graph by plotting static pressure error against IAS. Draw line which passes through most of the points. From this graph fill out static pressure correction card.

Once the static pressure error for the altimeter is known, an airspeed conversion factor can be applied to the altitude error to find the static pressure error in airspeed. To find this airspeed correction factor enter the static pressure correction chart with IAS and FLPA and find the correction factor. Multiply the correction factor by the error in altitude and the product is the static pressure correction in airspeed. This airspeed correction when applied to IAS gives CAS. The procedure for filling out the calibration card is the same as in the measured course method of airspeed calibration.

MAGNETIC COMPASS

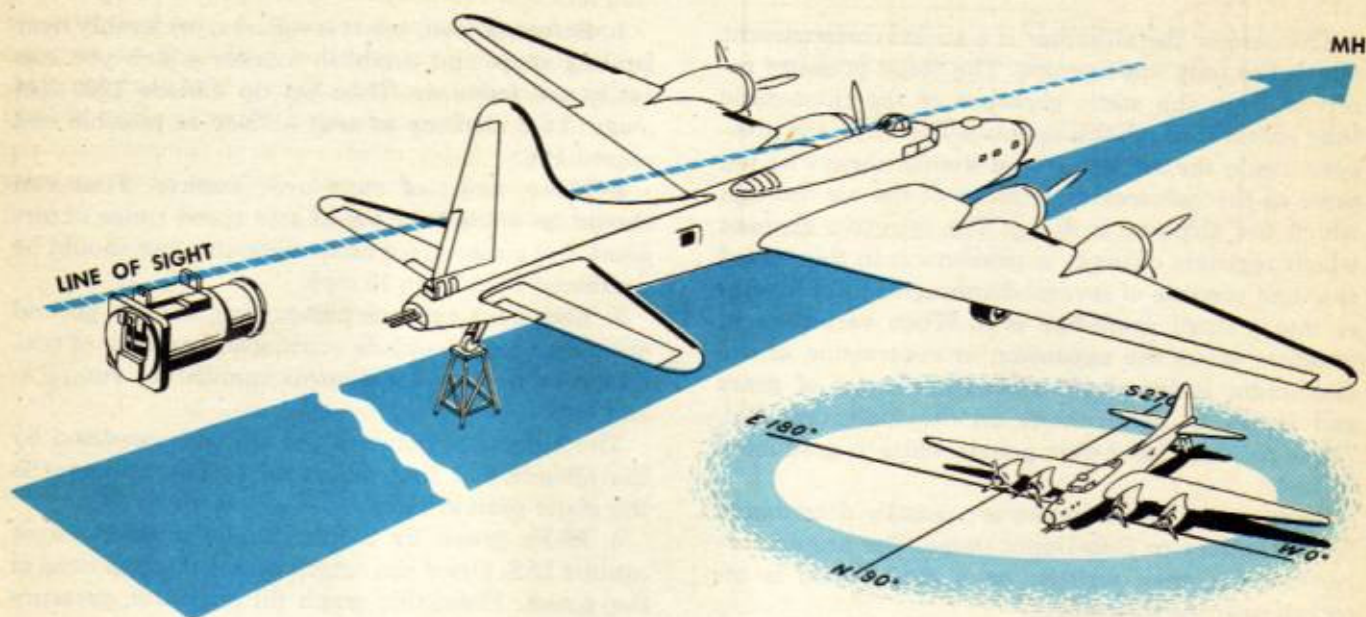

A compass is simply a magnetized needle suspended so that it will swing freely about its center. It is influenced by the earth's magnetism. One end of the needle tends to point to magnetic north. In an airplane, however, there are numerous metal parts and electrical circuits that combine to deflect the needle. This deflection, called deviation, is different for the various headings. Engine changes and changes in equipment and loading cause changes in deviation.

Compass deviations are found by swinging the compass either on the ground or in the air. Any procedure is satisfactory which will enable you to determine the magnetic heading of the airplane and compare it to the compass heading.

1. You may accomplish this on the ground by using an ordinary pilot's compass, which has had the compensator removed and a peep sight attached, to sight along the longitudinal axis of the airplane. Or

you can use a compass swinging base which is commonly found at Air Force installations.

2. You may find the actual magnetic heading of the airplane by first finding the magnetic bearing of a road, railroad, or some other straight line, and then using either the bombsight or the driftmeter to determine the angle between the heading of the airplane and the bearing of the road. Add this angle to bearing of road to get magnetic heading of airplane.

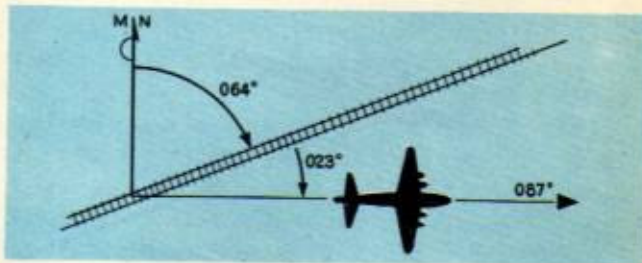

COMPENSATING THE COMPASS

In order to reduce deviations to a minimum it is necessary to compensate the compass before swinging it. The compensating device should be set to the 0 position or removed when the compensating swing is made. You may compensate the compass by either of 2 methods:

1. Turn airplane on magnetic north heading and adjust compass to 0°. Then turn airplane on east heading and adjust compass to read 90°. Now turn airplane to south heading and adjust compass to eliminate half of deviation. Follow same procedure on west heading.

	Compensating Swing			Residual Swing			Aircraft Comp.	
	Actual Head (M)	Aircraft Comp.	Dev's	Actual Head (M)	Aircraft Comp.	C to M	M to C	
N 000	005	001	+4				000	
NE 045							045	
E 090	087	090	-3				090	
SE 135							135	
S 180	176	180	-4				180	
SW 225							225	
W 270	265	273	-8				270	
NW 315							315	

If swinging compass used ahead of aircraft add or subtract 180 degrees.

Coef. C = $\frac{N-S}{2} - \frac{(E-W)}{2} - \frac{(L-R)}{2} = +\frac{8}{2} = +4$ OR $+4$

Coef. B = $\frac{E-W}{2} - \frac{(N-S)}{2} - \frac{(L-R)}{2} = +\frac{8}{2} = +4$

Coef. A = $\frac{N+E+S+W}{4} - \frac{(L+R)}{2} = \frac{(005+087+176+265)}{4} - \frac{(001+273)}{2} = \frac{533}{4} - \frac{274}{2} = \frac{533}{4} - \frac{548}{4} = -\frac{15}{4} = -3$

2. Turn airplane to each cardinal heading and record deviations on AAF Form 57. Then solve for coefficients A, B, and C by using equation printed on bottom of that form. Put airplane on north heading and add coefficient C to compass reading. This is compensated compass reading. Adjust compensator until compass gives you that reading. Turn airplane on east heading, apply coefficient B to compass reading, and adjust compensator. Turn airplane on any heading and apply coefficient A to compass reading. Loosen mount and rotate compass until compass gives compensated reading.

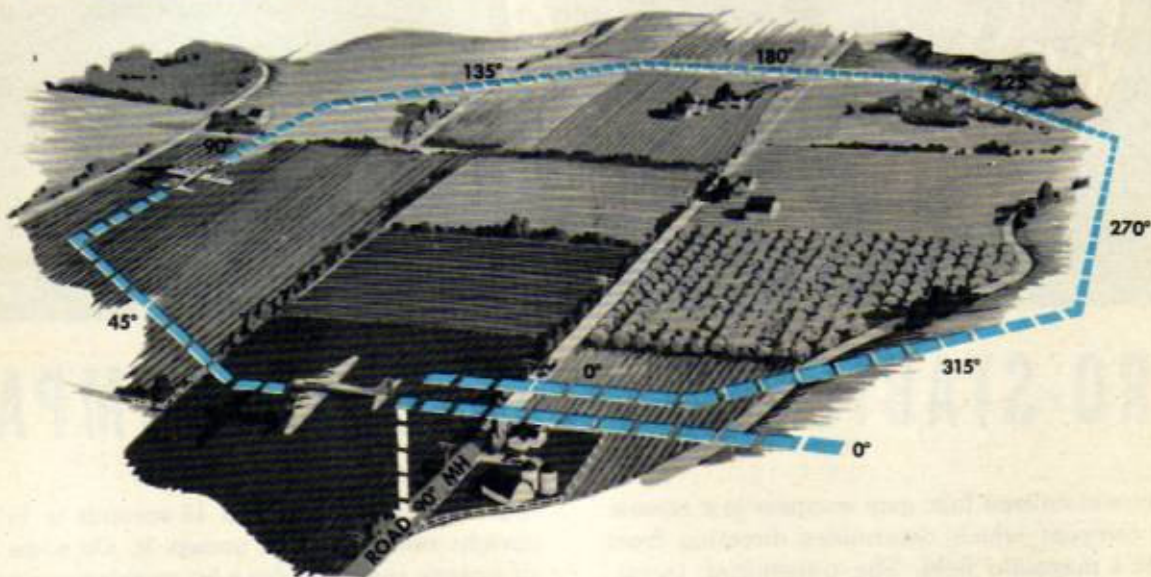

SWINGING THE COMPASS

This is known as the residual swing. Data concerning it should be recorded under Residual Swing on AAF Form 57.

1. Find some road or railroad of known bearing. Make 90° approach to it. Set 0° drift and engage bombsight clutch. Use turn knob to keep lateral crosshair parallel to road. Pilot must follow PDI.

2. Set directional gyro on correct magnetic heading, 90° from magnetic bearing of road.

3. Have pilot turn to left and fly on cardinal and quadrantal headings. He should fly same length of time on each heading. On every heading record readings of your compass and directional gyro.

4. Make final run over road on same heading and in same manner as before. Read directional gyro. Difference between this reading and correct magnetic heading is result of gyro precession. Divide this difference by number of headings and distribute pre-

cession cumulatively to find actual heading of airplane. For example, if error is 8° on 8 headings, allow 1° error on second heading, 2° on third, etc.

5. Complete deviation card part of AAF Form 57 and place it near compass.

	Compensating Swing			Residual Swing			Aircraft Comp.	
	Actual Head (M)	Aircraft Comp.	Dev's	Actual Head (M)	Aircraft Comp.	C to M	M to C	
N 000	005	001	+4	002 1/2	001	+1 1/2	000 -1/2	
NE 045				040	043	-3	045 +3	
E 090	087	090	-3	095	094	+1	090 -1	
SE 135				136	134	+2	135 -2	
S 180	176	180	-4	185	184	+1	180 -1	
SW 225				222	225	-3	225 +3	
W 270	265	273	-8	275	276	-1	270 +1	
NW 315				317	316	+1	315 -1	

If swinging compass used ahead of aircraft add or subtract 180 degrees.

Coef. C = $\frac{N-S}{2} - \frac{(E-W)}{2} - \frac{(L-R)}{2} = +\frac{8}{2} = +4$ OR $+4$

Coef. B = $\frac{E-W}{2} - \frac{(N-S)}{2} - \frac{(L-R)}{2} = +\frac{8}{2} = +4$

Coef. A = $\frac{N+E+S+W}{4} - \frac{(L+R)}{2} = \frac{(005+087+176+265)}{4} - \frac{(001+273)}{2} = \frac{533}{4} - \frac{274}{2} = \frac{533}{4} - \frac{548}{4} = -\frac{15}{4} = -3$

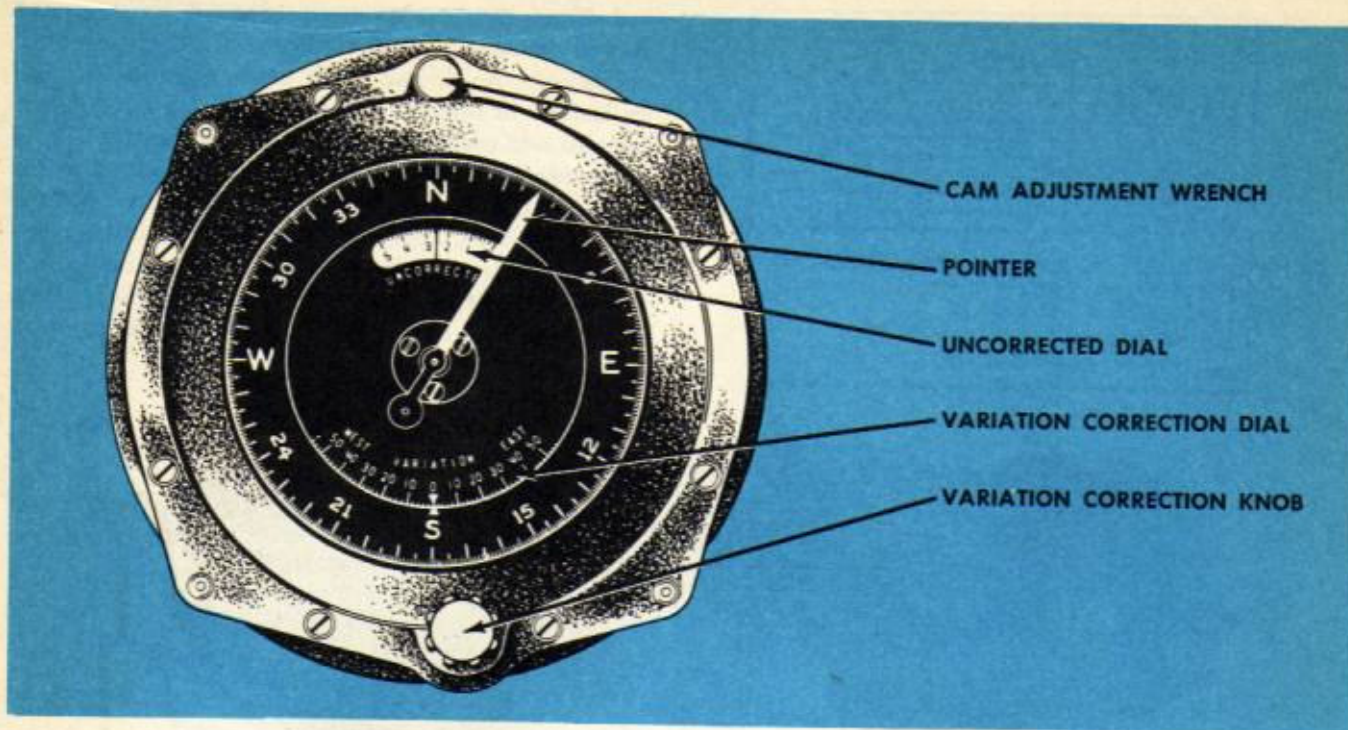

GYRO-STABILIZED FLUX GATE COMPASS

The gyro-stabilized flux gate compass is a remote reading compass which determines direction from the earth's magnetic field. The transmitter (sensitive unit) is located in the tail or wing of the airplane. In this remote position it is least affected by the magnetic field of the airplane and hence has small deviations. The sensitive element is stabilized by a gyroscope so that it is unaffected by turns, banks, climbs, yawing, or bumpy weather. The outer dial on the master indicator indicates magnetic heading and the small cutout indicates the uncorrected compass heading. The pointer of the compass indicates true heading (TH) when variation is set into the mechanism.

Operation

1. Turn variation correction knob to rotate outer dial until variation index is opposite variation for your position.
2. Keep amplifier switch ON at all times. Some late models do not have this switch; power is turned on with airplane master switch.
3. Follow caging instructions on face of remote control caging unit. After master switch has been ON at least 5 minutes and airplane is in flight atti-

tude, cage gyro for about 45 seconds to bring it to upright position. Then uncage it. On some new instruments caging is done by pushing caging button and holding it until red light comes on to show that gyro is erect.

4. Otherwise, leave gyro uncaged at all times.

Deviation in this compass is found in the same manner as in any magnetic compass. You perform the swing as usual, either on the ground or in the air, and take your readings from uncorrected dial.

When you have determined the deviations on 24 headings 15° apart unscrew the cam adjustment wrench from the top of the master indicator and remove the ring to expose the 24 adjusting screws.

If the deviation is 4° or more on any heading be sure to initiate the adjustment on the heading with least deviation. Thus the adjustment will be built up gradually to the point of maximum deviation. Never make an adjustment of more than 5° between two adjacent screws. On some new master indicators the 24 adjusting screws have been replaced by a compensating knob in the back of the instrument. By engaging this knob you can apply proper deviation correction for heading pointer indicates.

ASTRO-COMPASS

You use the astro-compass to determine the true heading of your airplane. However, you can use it also to determine true bearing and compass deviation. In either case the fundamental principles of operation are the same. When you use the astro-compass be sure that it is properly mounted and leveled.

Alignment

1. Place astro-compass in mount and level it.
2. Set latitude scale to nearest degree.
3. Obtain declination of sun from your Air Almanac and set it on astro-compass.
4. Set local hour angle (LHA) on local hour angle drum.
5. Rotate astro-compass until shadow of bar falls between parallel lines on shadow screen.
6. Read true heading at lubber line.
7. Note error of that position in dome is difference between astro-compass reading and TH of airplane.
8. Repeat this procedure for remaining positions and note errors. When possible, rotate mounting bracket to reduce errors to minimum.

Finding True Heading

Compass deviation is determined by comparing the TH of the airplane to the CH corrected for variation. To determine the TH of the airplane:

1. Place instrument in mount, level carefully.
2. Set latitude scale to nearest degree.
3. Set LHA of body to be observed on proper hour angle scale.
4. Set in proper declination.
5. Rotate bearing plate until sights are properly aligned on body.
6. Read TH of airplane at lubber line.

You can also steer a TH using this same procedure, **except:** Set TH you want to fly on bearing plate at lubber line; instruct pilot to turn airplane until selected body comes in your sights, and maintain this heading.

Finding True Bearing

To find true bearing of a ground object:

1. Properly mount and level astro-compass.
2. Set TH on bearing plate at lubber line.
3. Set latitude scale to 90°.

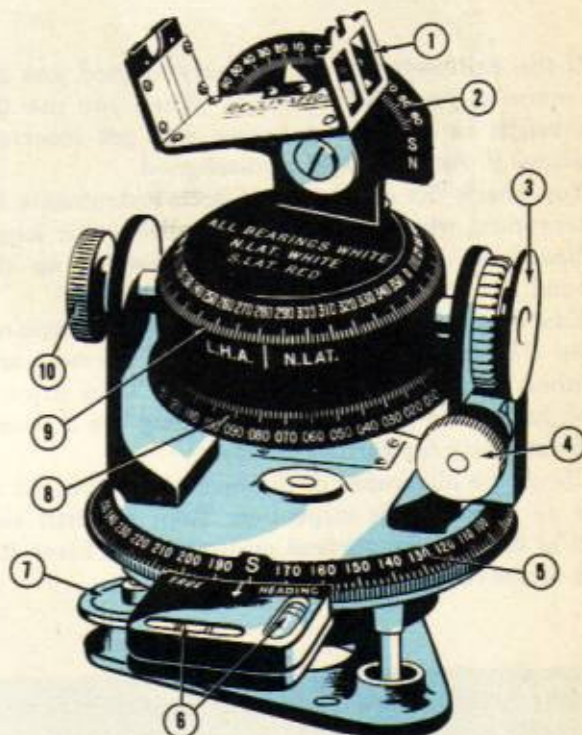

- | | |
|----------------------|---------------------------|
| 1. SIGHT | 6. CROSS LEVELS |
| 2. DECLINATION SCALE | 7. ADJUSTING SCREW |
| 3. LATITUDE SCALE | 8. SOUTH HOUR ANGLE SCALE |
| 4. LATITUDE KNOB | 9. NORTH HOUR ANGLE SCALE |
| 5. BEARING PLATE | 10. HOUR ANGLE KNOB |

4. Turn hour angle knob until you sight object.
5. Read true bearing on hour angle scale at hour angle lubber line.

Caution

When turning local hour angle scale, be sure to work knob in. Don't force it.

When observing sun be sure shadow of bar on front sight falls between parallel lines on shadow screen.

If observing any other body, look through small magnifying glass on rear sight and observe it through intersection of white lines in front sight. However, you can still get correct azimuth if body is vertically above or below intersection of white lines.

BOMBSIGHT AND DRIFTMETER ALIGNMENT

If the driftmeter is not properly aligned you get an error in your drift readings. When you use the bombsight as a driftmeter, you also get incorrect readings if the bombsight is misaligned.

You check the alignment of both instruments by determining whether they are parallel to the longitudinal axis of the airplane. Do this job on the ground.

First establish the longitudinal axis of the airplane. Drop a plumb-bob from the center of the nose and another from the center of the tail. Then draw a straight line on the ground connecting the 2 points and extending forward of the nose.

Check the alignment of the bombsight dovetail as you do in pre-flight inspection. Then set drift and trail at 0. Cage the vertical gyroscope and leave the rate motor turned off.

Engage the mirror drive clutch and rotate the displacement knob. If the fore and aft crosshair tracks parallel to the line under the longitudinal axis of the airplane, the bombsight is properly aligned. The correction of a misaligned bombsight usually is a job for the maintenance men.

To check the alignment of the driftmeter, first drop a plumb-bob from the center of the instrument to a point on the ground directly underneath. Draw a line through this point parallel to the longitudinal axis line of the airplane. Then rotate the driftmeter in azimuth until the center fore and aft wire is parallel to the longitudinal axis line. If the driftmeter is properly aligned, it will indicate 0° drift.

If the driftmeter does not indicate 0° drift, you can align it yourself. Loosen the 2 screws on the drift scale and rotate it until the drift indication is 0° .

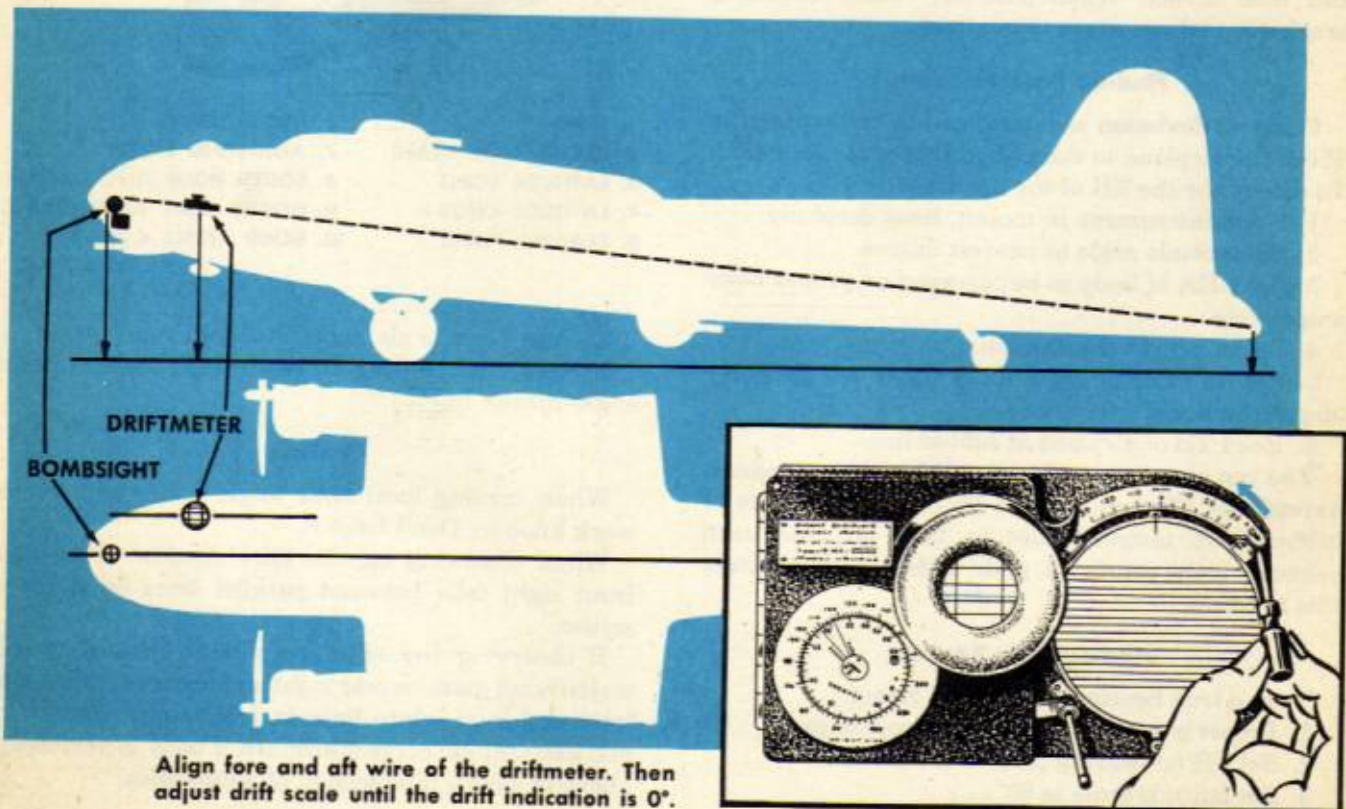

Align fore and aft wire of the driftmeter. Then adjust drift scale until the drift indication is 0° .



PILOTAGE NAVIGATION

Pilotage is the oldest form of navigation. Basically it corresponds to reading a signpost and following the directions. It is a simple method of determining the path of an airplane by observing objects on the ground. These reference points may be known landmarks or ones you can recognize from a chart. For them to be of any value to you, you must be able to determine the position of your airplane in relation to them. To navigate successfully by pilotage, you must have a good sense of direction plus an appreciation of how long it takes to go a specific distance at a specific speed.

Before each mission, have a clear conception of the general direction in which you intend to fly. Try to visualize your course. Don't plot it mechanically. Always remember that all headings for a particular destination must be in the same general direction. Study the chart carefully so that you have a definite pattern of your check points in mind. Always remember that wind affects your groundspeed and your direction or both and try to visualize the effect that it will have.

Aeronautical Charts

The charts which the AAF commonly uses are prepared so that each one serves a definite purpose. For example, **aeronautical planning charts** are on a gnomonic projection because extremely long flights are most easily and economically planned as great circles. Great circles on a gnomonic projection are straight

lines. The charts used on ordinary pilotage missions, however, are on the Lambert Conformal projection and thus give a minimum of distortion.

Regional charts cover a relatively large area. You can readily see that such charts cannot show much detail since it takes only 17 of them to cover the entire area of the United States. One inch represents 16 nautical miles. Because of the small scale, many distinct landmarks which you could use as reference points do not appear on a regional chart.

Sectional charts are made on a scale of 1 inch to 8 nautical miles. Consequently they cover a small area and show much detail. Landmarks are easily recognized. It requires 87 such charts to cover the entire area of the United States.

Approach charts are made on a scale of 1 inch to 4 nautical miles. They are designed to show prominent check points, terrain features, and other information that is of value to the various members of the air crew. Since they are detailed, they are of particular value in pin pointing objects such as your target, or positions in a small area.

Radio Direction Finding (RDF) charts are used to plot radio bearings when you navigate by radio aids. There are very few details on an RDF chart because it is made on a scale of 1 inch to 32 nautical miles. The entire area of the United States is shown on 6 of these charts. If there are no other charts available you can use an RDF chart for ordinary pilotage, but there is only a limited amount of information on it.

Chart Features and Color

You will probably use not only AAF charts but also charts our allies have prepared. These charts differ little from our own except in symbols and color.

Water factors are almost universally blue and are much the same no matter what chart you are using. Coast lines are usually represented with a high degree of accuracy. The course of a river is rather accurately represented but due to the small scale the width is seldom accurate. British charts, however, show rivers and lakes with an extremely high degree of accuracy. When preparing to use charts over unfamiliar territory always obtain in advance as much information about the local conditions as possible. Excessive rain may cause a stream to appear to be a river or drought may reduce a large lake to a small one or dry it up entirely.

Cultural or man-made features are usually shown in black on charts but there are important exceptions. For instance, villages and small towns on AAF charts are represented by dots or small circles but on British charts they are drawn to a scaled size and shape, just as cities are on American maps. Invariably railroads are represented by black lines. The chief difference is that the British show trunk lines in heavy lines and single tracks in lighter lines, whereas we denote different classes of railroads by the spacing of cross marks. Highways are represented by

lines the width of which depends on the prominence of the road as it appears from the air. American charts show these lines in grey; the British show them in red.

Relief is almost universally represented by some scheme of graduated colors from light to dark. Here again, British and American charts differ to some extent. We use a light green which graduates into tan and finally into dark brown at elevations above 9000 feet. They use white which grades into purple at the higher altitudes.

Forest areas usually do not mean very much when you see them on AAF charts. On British charts, though, they serve as excellent check points because of the accuracy with which their shape is plotted.

Aeronautical information probably varies more in the way it is represented than any other feature. The symbols are sometimes similar but require careful study and almost invariably the colors used for the symbols are different.

Special Points in Pilotage

Lines of position and fixes are of great value when you cannot see any of the check points you have planned to use and yet you can find lines and landmarks of sufficient prominence to be recognized. Pin point positions located in this manner are readily plotted on your chart and proper course corrections can be made.

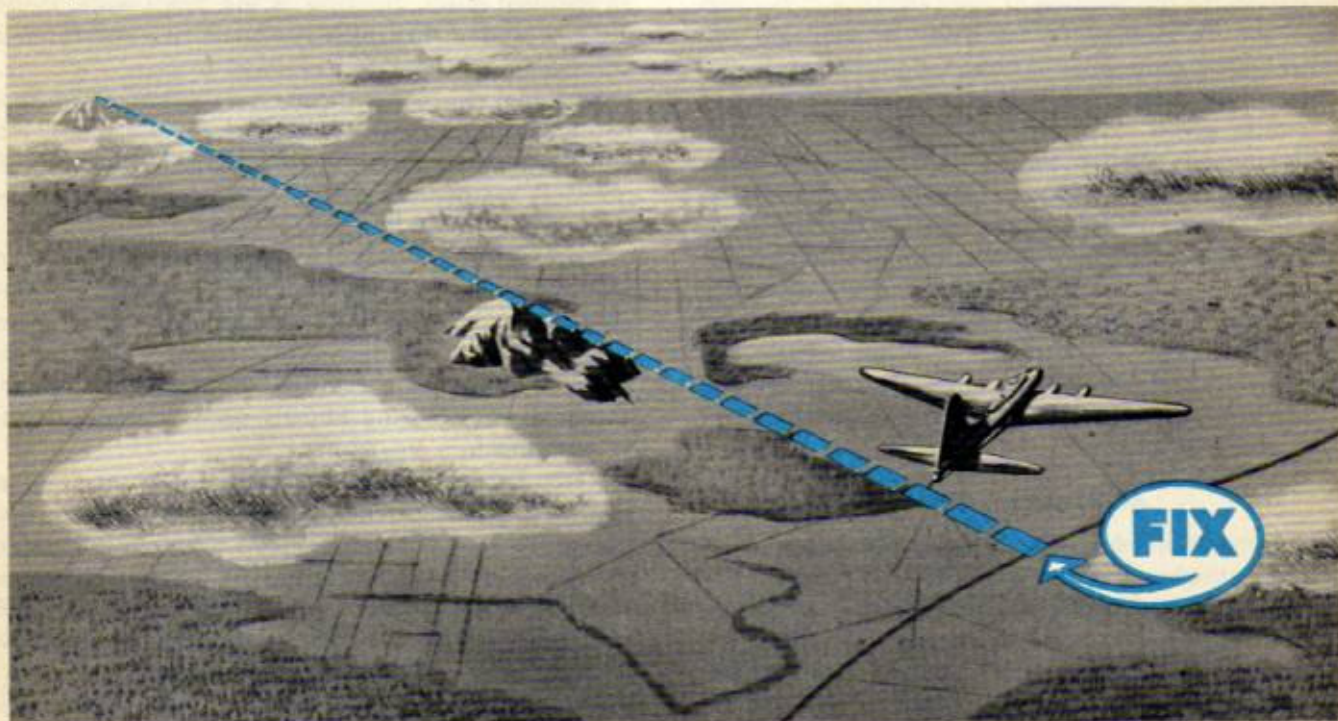

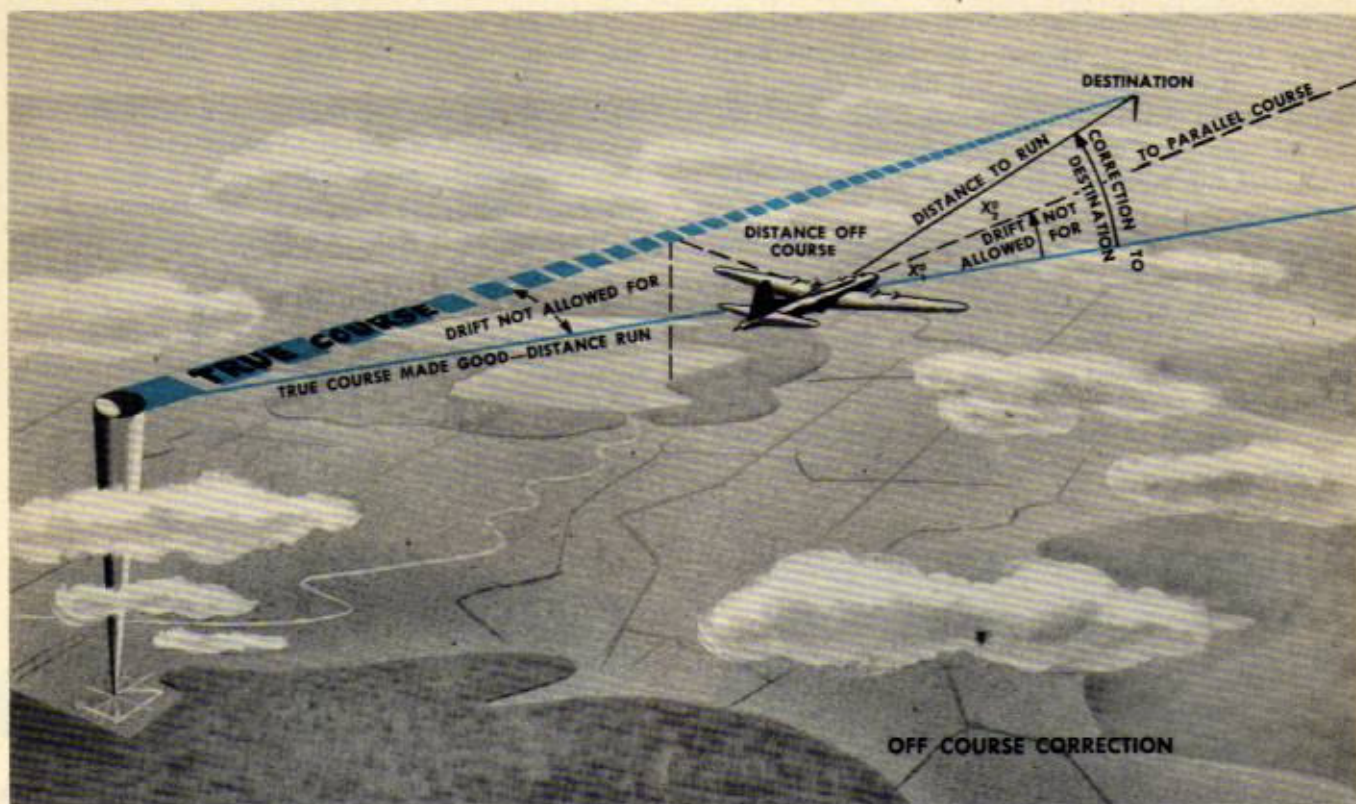

Off-course corrections may be made in a number of ways. One of the easiest ways is to solve the two following equations on the slide rule face of the E-6B computer.

$$1. \frac{\text{Distance off course}}{\text{Distance run}} = \frac{X_1^\circ}{60}$$

$$2. \frac{\text{Distance off course}}{\text{Distance to run}} = \frac{X_2^\circ}{60}$$

The sum of the two unknowns ($X_1^\circ + X_2^\circ$) is the total number of degrees to correct.

Rule of Thumb. In traveling 60 miles, each mile off course requires 1° correction to parallel your intended course. By correcting 2° for each mile off course, you regain your intended course in 60 miles.

If you have traveled more or less than 60 miles, multiply the 1° correction per mile off course by 60 and divide by the distance traveled. For example, if you have traveled 30 miles multiply the 1° correction per mile off course by $60/30$, or 2, to parallel your intended course.

Pilotage logs. To navigate successfully it is necessary that you keep a comprehensive record of the flight. This insures your doing each detail of the work when it should be done and furnishes an orderly method of keeping your information on weather,

fuel consumption, wind, position, time, airspeed, course, and heading constantly before you. When making computations or recording data, **always** take the average indication of the instruments; compute groundspeeds from point of departure; and clock your check points from the same angle of sight to prevent errors in timing and measuring distance.

Check points are of prime importance in pilotage. After plotting the course on a pilotage chart, look along the course line and pick out your check points. Select good ones. A good check point must be prominent, distinctive, and unusual in its surrounding area. Make sure your check point is not duplicated somewhere nearby. Try to select shapes, patterns, or combinations that you can easily recognize. For example, a railroad that crosses a river at a certain angle. Since you use check points as reference for measuring time and distances, don't select a large area.

Don't learn to rely too strongly on any one type of check point. In Europe, for example, cultural check points are plentiful but in parts of the Far East you must depend on relief or distinct land-water combinations. When flying your mission, dismiss from your mind all confusing small details of the chart and concentrate on the prominent features you have chosen to guide you.

Pilotage winds may be determined in several different ways. Almost without exception if you keep any record of the flight you will have sufficient information on drift, TH, TAS, and GS to solve for the pilotage wind on the E-6B computer or graphically. Use the method that requires the information you have.

The air plot affords a convenient way of finding the wind. You can do this easily by noting the coordinates of your air position and your exact pilotage position. Scale off the distance from departure on the TH. Then draw a line from your air position to your ground position. The length of this line represents the speed of the wind and its direction from heading to course is the direction of the wind.

Night pilotage is usually easier than or just as easy as pilotage in daytime. The light patterns of cities, airfields, and so forth are more distinct in shape and you can see them at a greater distance. Water features are always of great value at night. This is especially true in combat areas because water is almost impossible to conceal by blackouts. Even on dark nights it reflects sufficient light to be distinguished easily. On dark nights you can readily pick out roads and highways because normal traffic usually is sufficient to make them show up clearly. By observing the automobile lights you can readily recognize the turns in the road. However, in combat areas do not plan to use any feature that must be identified by lights.



Light patterns help to identify towns and cities.



Silhouettes of ridges, mountains make good check points.



Automobile headlights often trace highway routes.



Water areas reflect light even on dark nights.



DEAD RECKONING NAVIGATION

Dead reckoning is the basic method of navigation. It is a method of navigating by means of instruments and computations when flying without the aid of distinct landmarks or when flying over water. It is often possible to navigate by DR when it is not possible to use any other method. Generally you use DR in conjunction with other methods. This greatly increases your assurance of successful navigation.

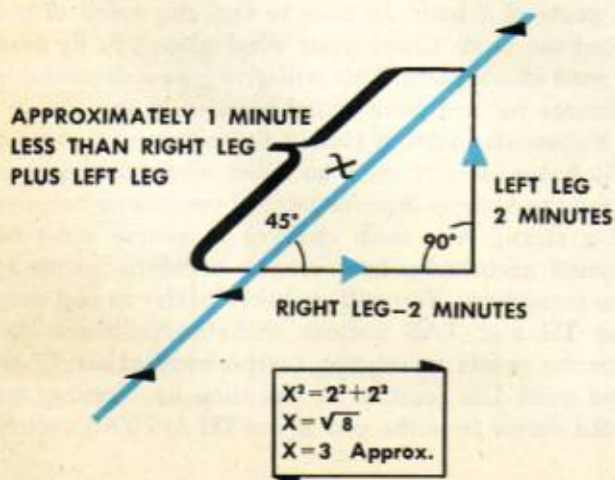

To navigate by DR successfully, you must read your instruments accurately and determine the correct wind. Consequently, make frequent checks to find if a change has occurred. Do not rely entirely on a metro wind. Use it only to set course. Then check it with a double drift or other wind solution and correct the heading. Remember, if you are making a double drift solution, **2 minutes spent on each leg cause a loss of 1 minute on course.**

DR logs are similar to pilotage logs in that they are simply an ordinary record of the flight. They are available as a reminder to do the various details of your work as you come to them.

When you take drift readings or compute GS, always use immediate heading, TAS, and wind direction and speed. Do not use average values.

In making position reports use time and distance from last known position. Do not use total time and distance as you do in pilotage.

Record positions by coordinates and altimeter readings in pressure altitude. You will find this makes it convenient in doing your computations.

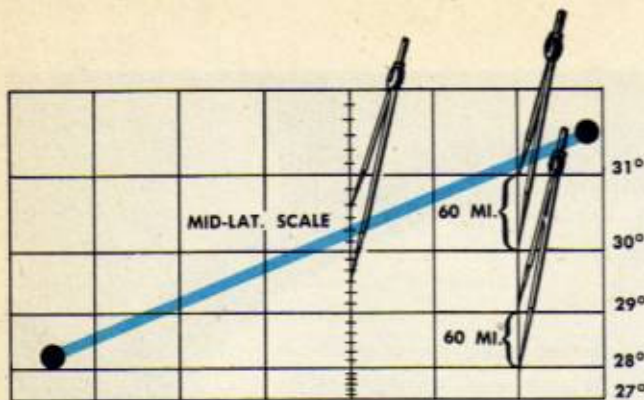

Mercator charts are used in DR for they make the plotting of course angles and distances easy. Always remember to use the mid-latitude scale in measuring distances. If at any time while you are doing DR you need to check your location, it is easy to read the coordinates of your position from the Mercator chart and transfer them to a regional or sectional chart.

Groundspeed can be found quickly by use of the bombsight or driftmeter. When you use the B-5 driftmeter, determine the drift and while the driftmeter is still set on this drift, time the passage of some object from the front to the rear transverse wire. Use the circular computer on the side of the driftmeter. Set time for passage of object on the inner scale, opposite true altitude above object on outer scale. Opposite knots marker find GS in knots on outer scale.

When you use your bombsight to find GS, select any reasonable DS setting and 0 trail. Synchronize on some object on the ground. Record DS used and Tan WR/L set up. Compute true altitude above object synchronized on and use this as BA in the equation:

$$GS \text{ (mph)} = \frac{DS \times BA}{7773} \times \text{Tan WR/L}$$

Solve this equation on your E-6B computer.

Controlled groundspeed is frequently used in order to reach your destination at a specified time. To do this you must determine the IAS necessary to make good a definite GS. This problem is simply the reverse of the regular DR procedure of determining GS from instrument readings and wind.

To solve the controlled groundspeed problem plot the TC from departure to destination and divide the distance by the time allotted for the flight. This gives you the GS which you must make good. Set TC, GS, and wind direction and speed on the E-6B computer to determine the TH and TAS you must make good. Then use the E-6B computer to determine the CAS needed to make good this TAS. Apply the calibration correction to the CAS to find the IAS at which the

pilot must fly in order to achieve the required GS. Apply variation and deviation to the TH you must make good to find the compass heading at which the pilot must fly.

Air plot is a convenient form of navigation in that you may start it from any known position. In plotting values on the Mercator chart always use the average TAS and TH on each leg. Plot all of your winds from TH and use the average wind to plot the final wind vector. Be sure to keep an accurate record of the air plot. To avoid confusion, label the turning points as air positions. **Take sufficient readings to get good averages.**

You may average the wind by either of 2 methods. If the directions of all the winds which you are averaging are in the same quadrant, use mathematical averages. When the wind directions vary greatly or the wind speeds change over a large range, you can get a more accurate wind by adding all the winds vectorially and finding the resultant direction and speed. The resultant speed is for the elapsed time for all winds plotted. Since your computations are made

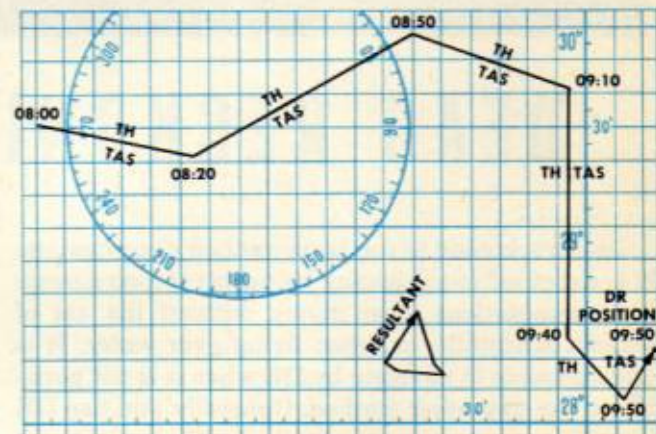

in units of 1 hour, be sure to find the speed of the wind per hour. Check your wind when you fly over a good check point. This will give you a dependable pilotage fix and your actual position in the air.

Follow the pilot is simply the reverse of regular DR procedure. It may be used when the pilot is forced to alter course for tactical reasons or because of a storm. Any such changes in course must be plotted accurately, however, in order to return to the home base. You will probably prefer to plot only the TH and TAS vectors with the positions and turning points in relation to the body of air. Then find your DR position at any time by plotting the wind vector from the end of the TH and TAS vector.

RADIO NAVIGATION AIDS

Radio aids are valuable in all navigation, contact or instrument. You should make the fullest practical use of radio facilities to aid you in your navigating. Obviously it would be foolish to depend upon radio navigation alone. Several conditions might arise that would make such navigation impossible.

Static, for example, is the greatest hazard to radio navigation. During electrical storms radio reception is sometimes impossible, making it necessary for you to use other methods.

Then too, atmospheric conditions affect navigation by radio. Sometimes you can't make contact with range stations 10 miles away. Don't think immediately that your radio is out. Fly out your ETA over the station and try contacting it again before you conclude that you are off-course.

Using Radio Range Beam Legs

Use radio range beam legs just as you use visual check points. Use them at all times on both instrument and contact flights.

Here is an example:

Assume you have taken off from Charlotte to fly to Norfolk. After takeoff the radio is tuned to the Greensboro range to determine your position in area X thus: If west of the Greensboro southeast leg, you hear the Greensboro N signal; if east, the Greensboro A signal. In both cases the strength of the background (on-course) signal determines your proximity to the Greensboro southeast leg. A solid on-course signal of the Greensboro southeast leg indicates the general position along the line of flight. As you progress along the flight you can tune to successive sta-

tions adjacent to your route and identify your position relative to them.

International Morse Code is used for all code signals in radio navigation.

Radio in conjunction with visual checkpoints is an easy method of determining your position.



If you are flying off the airways you can find your exact position at the beam intersection by using both the beam and river as check points.

Radio Compass

The radio compass is a receiving apparatus which senses direction and therefore is a valuable navigational aid. When using the radio compass you depend upon the directional loop to determine your direction from the radio station to which you are tuned. The bearing indicator needle of the automatic radio compass points to 0° when the airplane is headed toward the station to which the set is tuned. A crosswind, of course, causes the airplane to drift to one side or the other of the bearing toward the station.

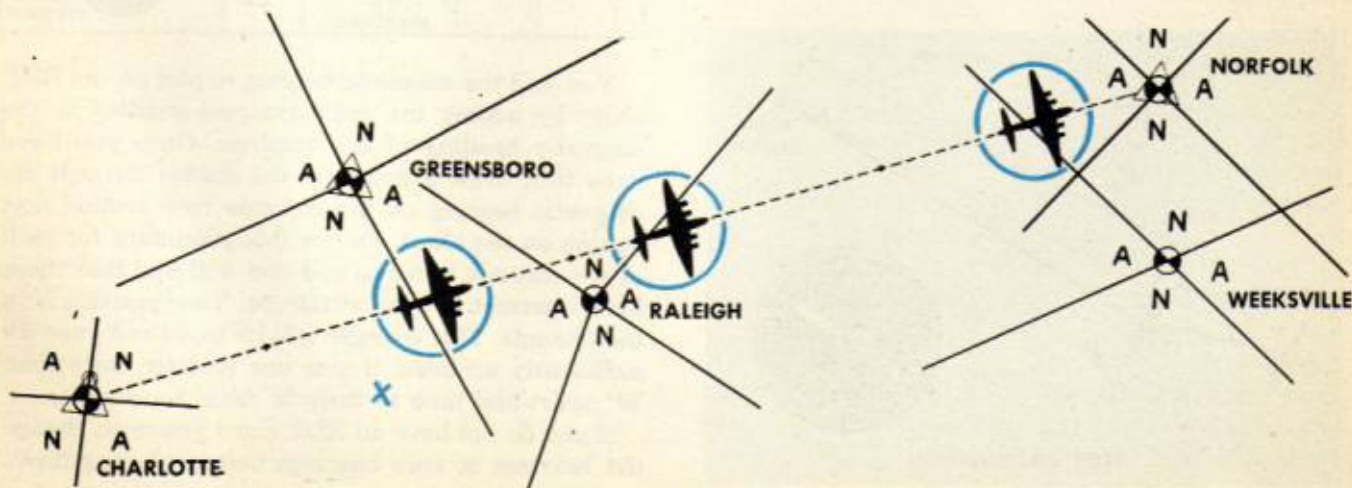

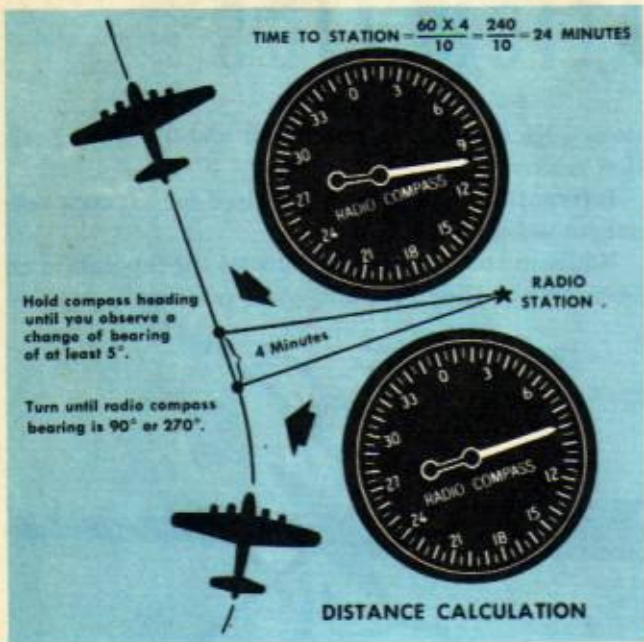

Drift becomes apparent when you note the movement of the indicator needle away from 0° while a constant gyro heading is being flown. The change in reading of the needle may be used to calculate distance to station and necessary drift correction.

To compute the distance to a station, turn the airplane until the azimuth is on 90° or 270°. Hold a constant heading. Note the time required for a reading change of approximately 5°. Compute the distance or time to the station by the equations:

$$\text{Minutes to station} = \frac{60 \times \text{Minutes flown between bearings}}{\text{Degrees of bearing change}}$$

$$\text{Distance to station} = \frac{\text{TAS} \times \text{Minutes flown between bearings}}{\text{Degrees of bearing change}}$$

This method is reasonably accurate unless there is a strong wind.

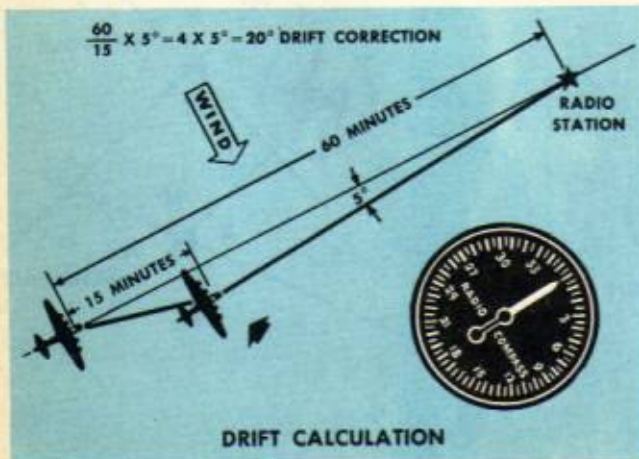

To find the necessary drift correction after the distance to the station is known, fly a gyro heading toward the station and note the change in radio compass bearing after flying a reasonable length of time. Divide the total time to the station by the time flown and multiply the result by the number of degrees change in the radio compass bearing. This value is the drift correction in the direction indicated by the radio compass needle.

How to Take Fix with Radio Compass

When you take a fix with the radio compass, locate the stations you expect to use on an RDF chart, tune in and identify them, and record the exact tuning dial reading for each station. You then can tune rapidly from one station to another and keep errors to a minimum. Fly a constant heading while you tune to the selected stations in rapid succession and record the radio compass readings.

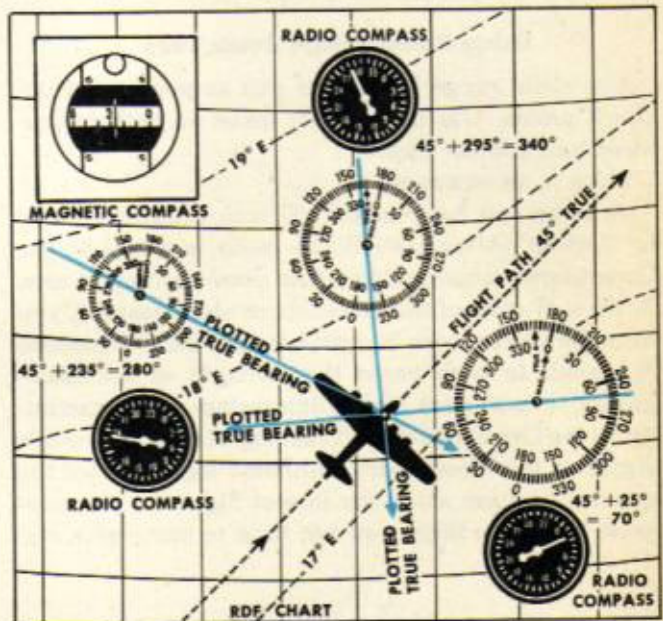

You find the magnetic bearing to plot on the RDF chart by adding the radio compass reading to the magnetic heading of the airplane. Once you have done this, draw a line from the station through the magnetic bearing on the compass rose around that station on the chart. Follow this procedure for each of the stations tuned to and you will find that these lines intersect to form a triangle. Your position is in the triangle. This triangle will be small and your fix sufficiently accurate if you use stations more than 30° apart and tune to them in rapid succession.

If you do not have an RDF chart you must change the bearings to true bearings before plotting them.



SECTION

5

C-1 AUTOPILOT...

The C-1 autopilot automatically controls the airplane in straight and level flight, or maneuvers it in response to the fingertip control of the pilot or bombardier.

The precision of even the most skillful human pilot is limited by his reaction time. Reaction time in turn varies with fatigue, inability to detect deviations the instant they occur, errors in judgment, and muscle coordination.

The autopilot, on the other hand, detects flight deviations the instant they occur, and just as instantaneously operates the controls to correct them. When properly adjusted, the autopilot neither overcontrols nor undercontrols the airplane, but keeps it flying straight and level with all three control surfaces operating in proper coordination.

You must know how to preflight, engage, and adjust your autopilot. You will be able to perform these operations more thoroughly if you also learn the functioning of its various units. Then, when maladjustments occur, you will know how to correct them.

No longer does anyone deny that use of the autopilot greatly improves bombing accuracy.

NOMENCLATURE AND FUNCTIONING

STABILIZER

1. DIRECTIONAL ARM LOCK
2. DASHPOT
3. DIRECTIONAL PANEL
4. DIRECTIONAL PANEL ARM
5. AUTOPILOT CLUTCH ARM EXTENSION
6. AUTOPILOT CLUTCH
7. AUTOPILOT CONNECTING ROD
8. DRIFT GEAR CLUTCH
9. PDI
10. BOMBSIGHT CLUTCH

DIRECTIONAL PANEL

1. RUDDER PICKUP POT AND WIPER
2. SLIDING BLOCK
3. ERECTING CUTOUT SWITCH
4. DUAL BANKING POT AND WIPERS

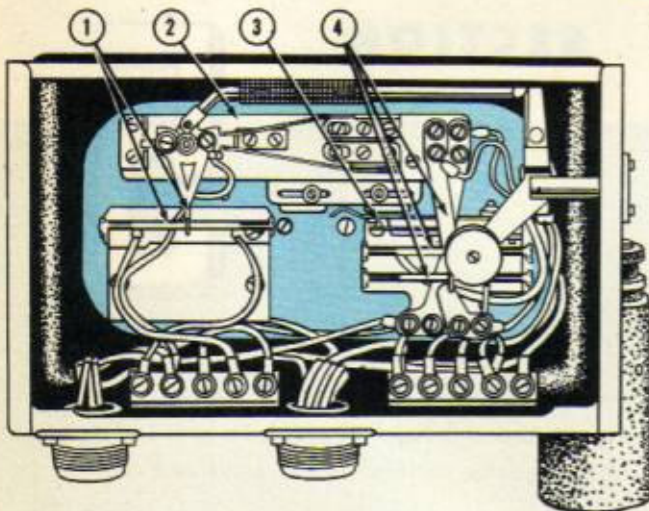

Stabilizer

The directional gyro of the bombsight stabilizer detects any deviation of an airplane from **straight** flight. The autopilot clutch connects the directional gyro to the directional panel. The directional panel, attached to the side of the bombsight stabilizer, measures electrically the deviations which the directional gyro notes. Signals then are produced which direct the servo units to correct the deviation.

If you want to steer the airplane by the autopilot clutch, disengage it. This disconnects the directional gyro from the directional panel. Now, you are in control of the directional panel and, through it, you also control the servo units. When you move the autopilot clutch you cause the airplane to turn.

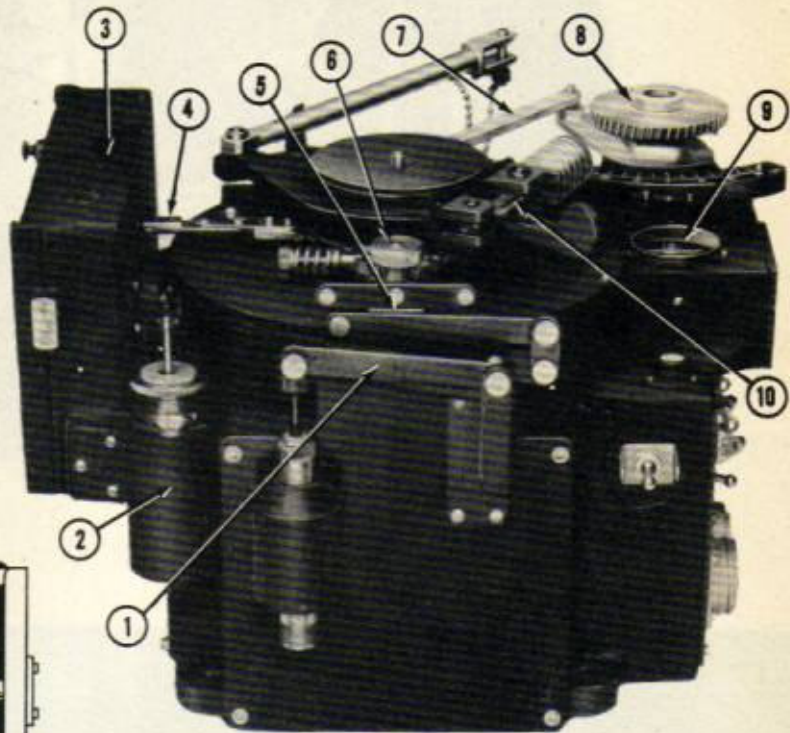

The airplane resumes straight and level flight when you again engage the autopilot clutch to the directional gyro, or when you return the clutch to center by hand.

The directional arm lock prevents the directional panel from cancelling out signals put in by the turn control when you are using it to make a turn. When the turn control is moved from **CENTER**, the solenoid of the directional arm lock causes the clamping jaws to lock the autopilot clutch arm in position. The autopilot clutch slips throughout the turn. As soon as you put the turn control back in **CENTER**, the autopilot clutch enables the directional gyro to stabilize the airplane on its new heading.

The dashpot is linked to the mechanism in the directional panel which produces the signal for rudder control. It increases the signal for initial rudder correction as the speed of the airplane's yaw increases. You can govern the extent of increase in that signal by adjusting the knurled nut on top of the dashpot.

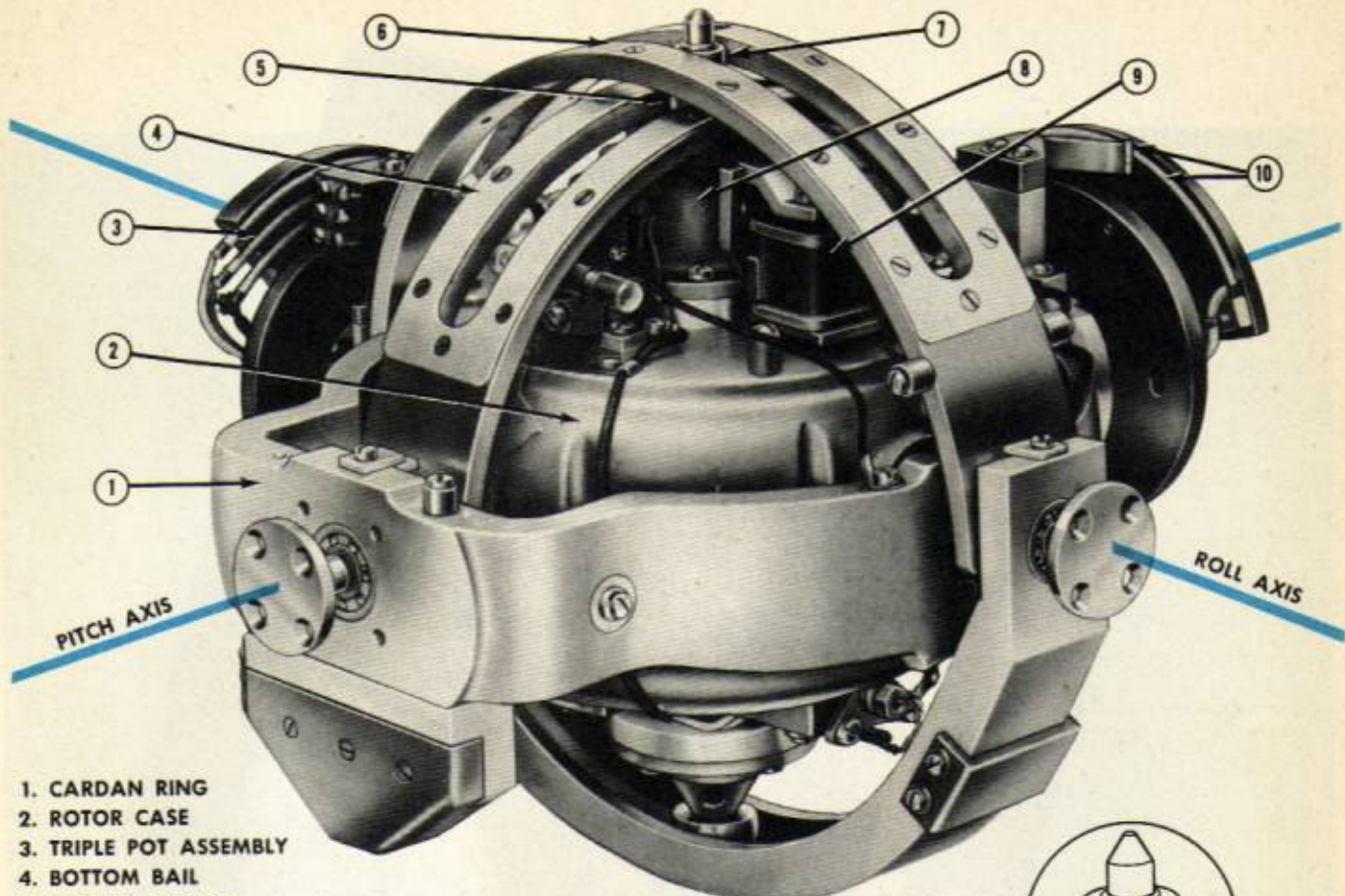

1. CARDAN RING
2. ROTOR CASE
3. TRIPLE POT ASSEMBLY
4. BOTTOM BAIL
5. BOTTOM ROLLER
6. TOP BAIL
7. TOP ROLLER
8. AUTOMATIC ERECTION SYSTEM
9. ERECTING CUTOUT MECHANISM
10. ELEVATOR PICKUP POT AND WIPER

Vertical Flight Gyro

The autopilot's flight gyro detects any deviation of an airplane from level flight. It is mounted near the airplane's center of gravity. The flight gyro measures electrically any deviation it picks up. Signals then are produced which direct the servo units to apply control to correct the deviation.

Unless the flight gyro remains vertical, it becomes an inaccurate reference and you no longer can depend on it to maintain the airplane in level flight. Its automatic erection system keeps it constantly in a vertical position, but when this erection system functions while the airplane is in a turn it causes the flight gyro to assume a false vertical. To prevent this, the erection system is automatically disengaged whenever you make a turn control or directional panel turn.

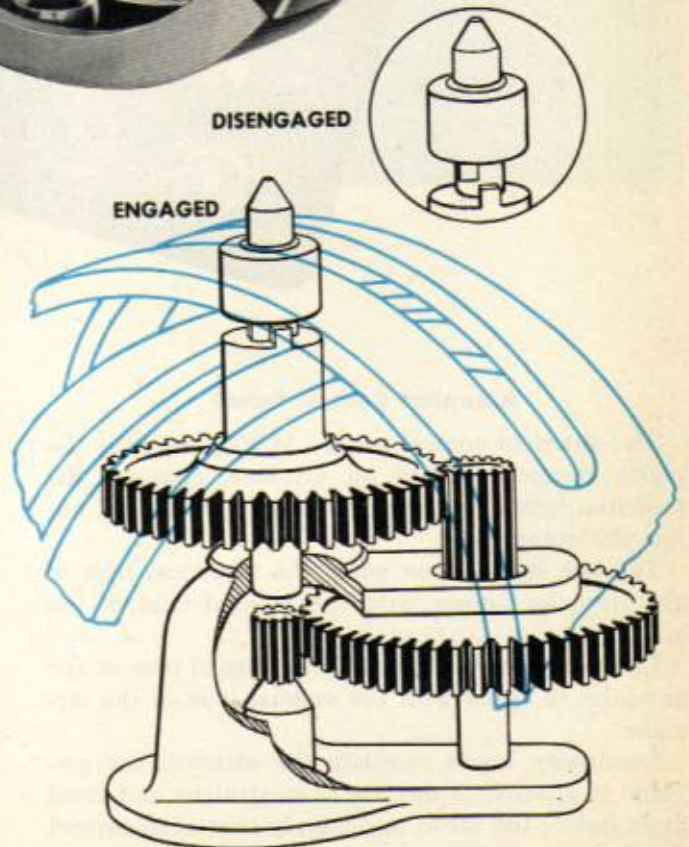

AUTOMATIC ERECTION SYSTEM

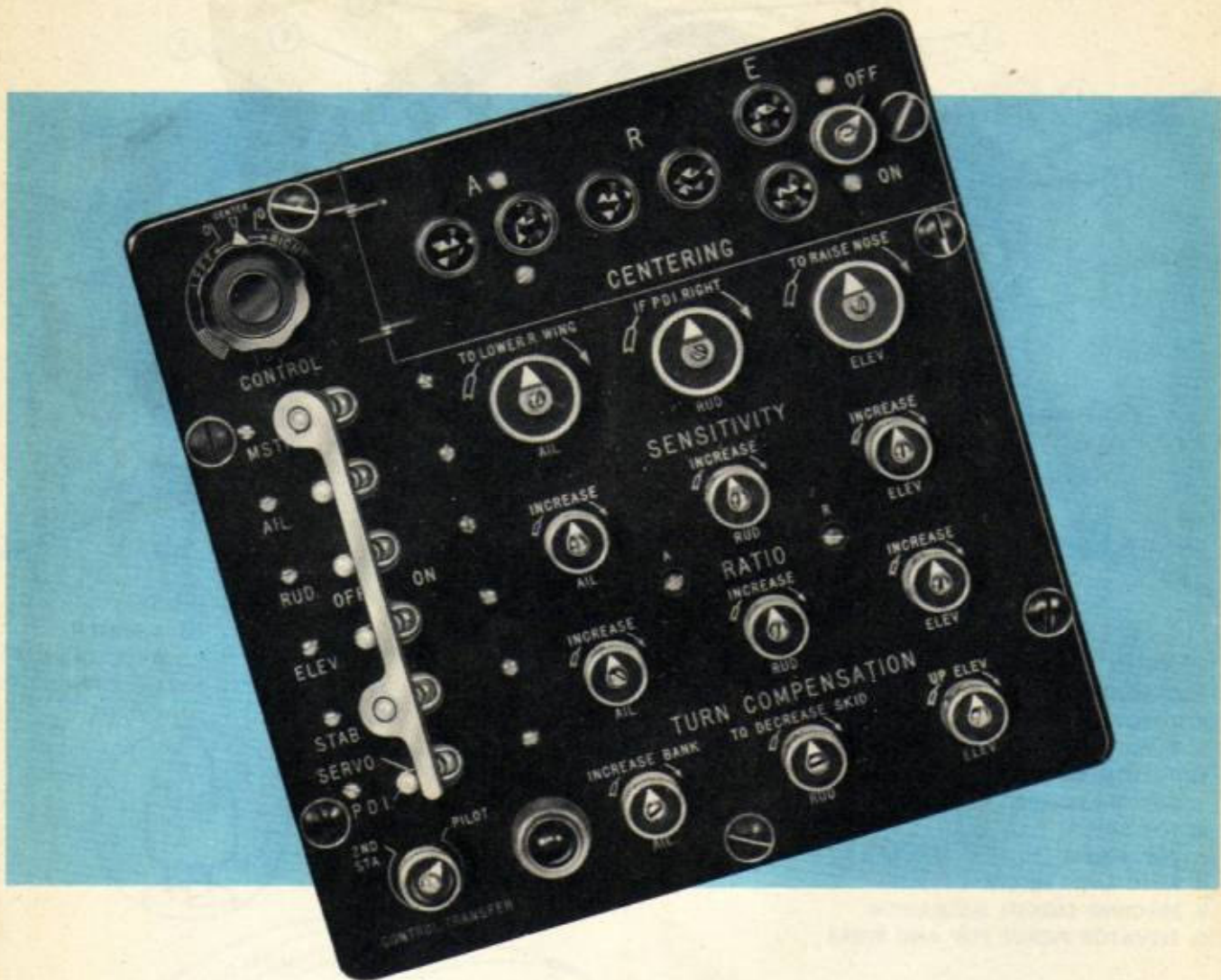

Autopilot Control Panel

The autopilot control panel (ACP), located in the pilot's compartment of an airplane, contains the switches, lights, and knobs used to operate and adjust the autopilot.

Tell-tale lights show when the electrical trim of the autopilot agrees with the manual trim of the airplane.

Centering knobs change the electrical trim of the autopilot to agree with the manual trim of the airplane.

Sensitivity knobs regulate the distance the airplane is allowed to deviate from straight and level flight before the servo units apply control to correct the deviation.

Ratio knobs regulate the amount the servo units move the control surfaces for any given deviation of the airplane.

Turn compensation knobs regulate the amount of control necessary when the directional panel is used in making a coordinated turn.

Turn control enables the pilot to make coordinated turns with the autopilot.

Aileron and rudder trimmer screws regulate the amount of aileron and rudder control necessary to make a coordinated turn with the turn control.

Remote control transfer knob shifts the turn control operation to a remote turn control station in either the bombardier's or navigator's compartment.

Tell-tale light shutter knob regulates the brightness of the tell-tale lights.

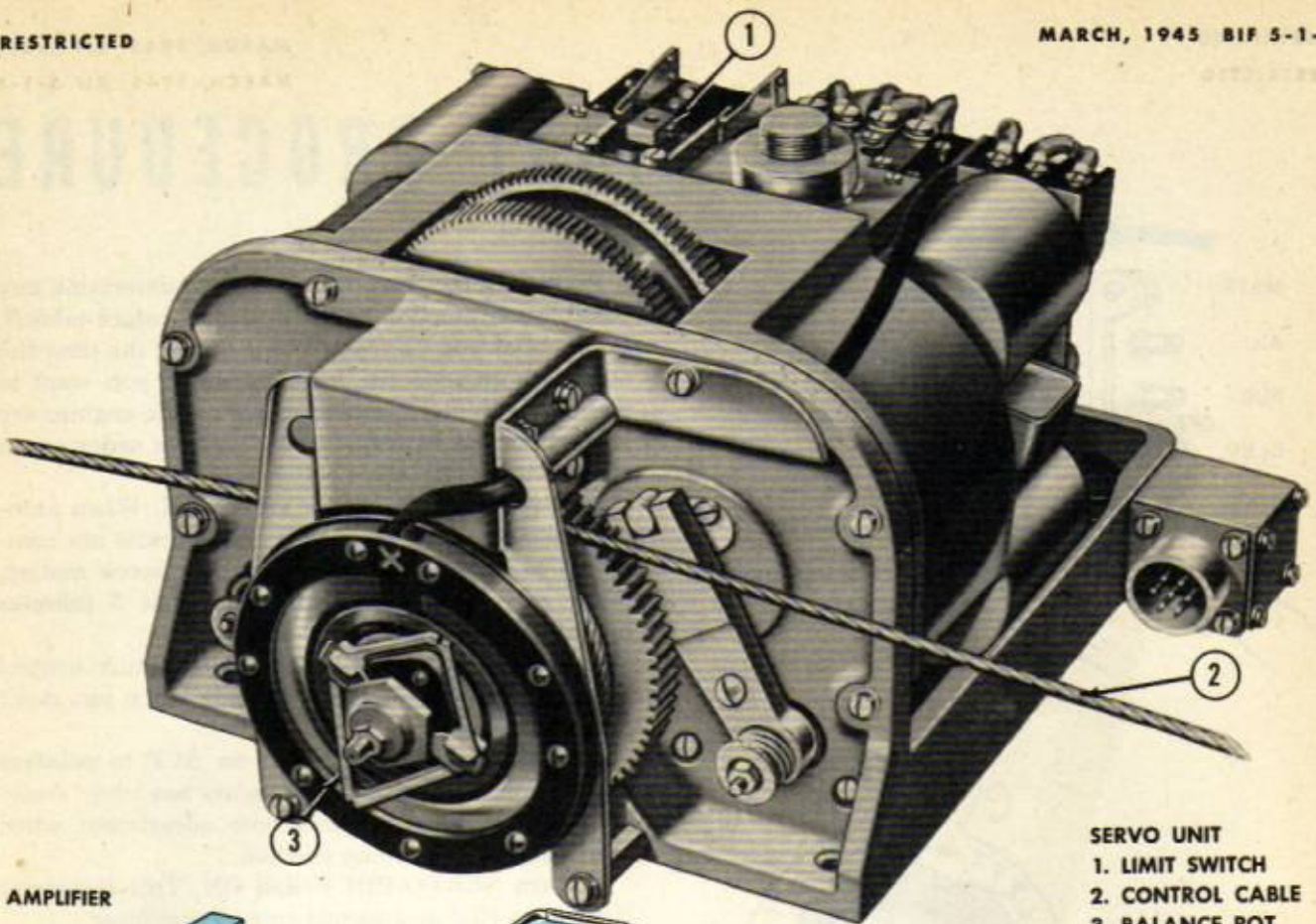

SERVO UNIT
 1. LIMIT SWITCH
 2. CONTROL CABLE
 3. BALANCE POT
 AND WIPER

AMPLIFIER

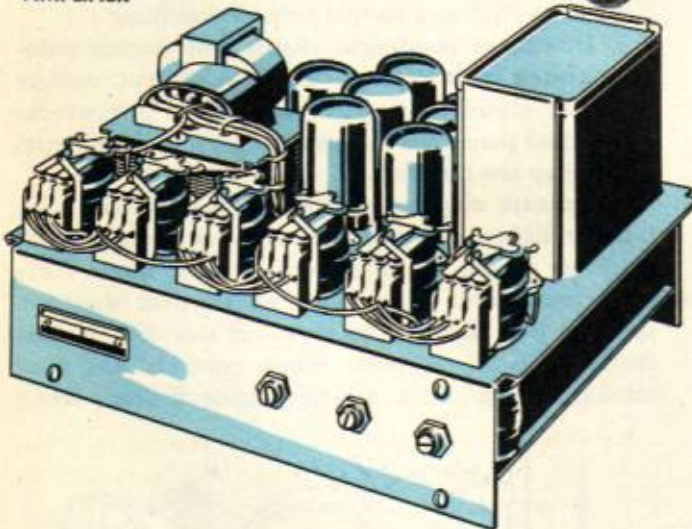

Servo Units

The servo units provide the mechanical force necessary to move the airplane's control surfaces. There is one servo unit for each control surface and it is located as close as possible to the control surface which it moves. Servo units are connected to control surfaces by cables clamped to the regular control cables of the airplane.

Servo units are so built that they are easily overpowered if, in an emergency, the pilot has to take over control of the airplane himself.

Amplifier

The amplifier is essentially the brains of the autopilot. It receives the electrical signals sent by the other units. It amplifies these signals which direct the proper servo units to apply a definite amount of control in the desired direction.

Rotary Inverter

The rotary inverter is a generator which provides the alternating current necessary for the operation of the autopilot. The inverter operates on direct current from the airplane's power supply.

Junction Box

The junction box provides a convenient place to connect the wiring from the various units of the autopilot. As a central wiring station, it saves wire and makes it easier to check the various circuits.

PREFLIGHT PROCEDURE

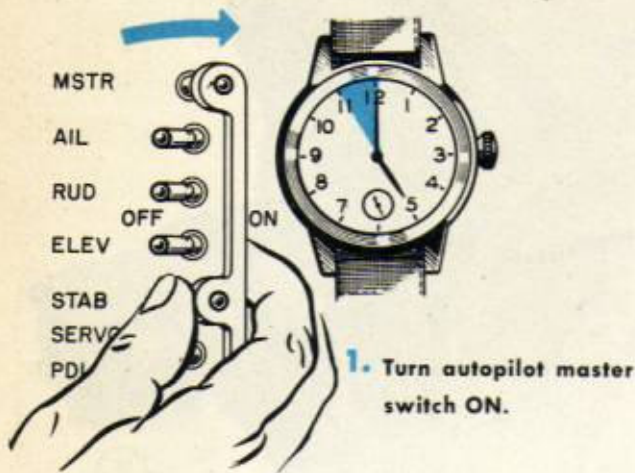

1. Turn autopilot master switch ON.

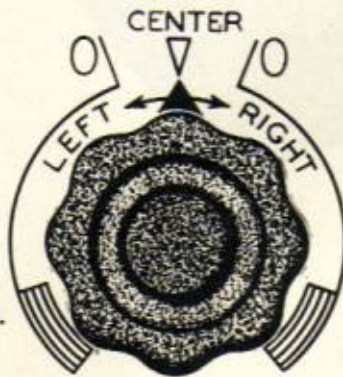

2. Center turn control.

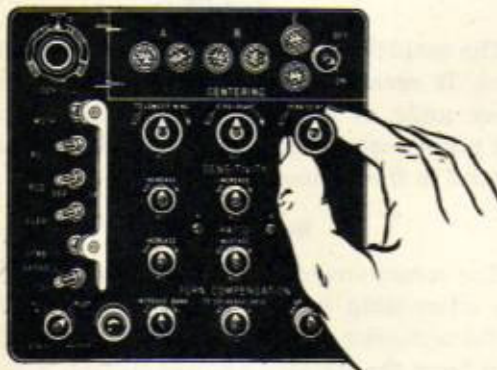

3. Turn all adjusting knobs on ACP to pointers up position

4. Turn SERVO-PDI switch ON.

Preflight procedure allows you to determine any possible malfunction of the autopilot before takeoff. It's so brief you can complete it during the time the airplane's engines are warming up. If you want to make this preflight inspection before the engines are started, have a battery cart available in order not to run down the airplane's batteries.

1. **Turn autopilot master switch ON.** When autopilot master switch is turned ON, circuits are completed to directional gyro, amplifier, servo motors, flight gyro, and rotary inverter. **Wait 5 minutes** before turning other switches on.

2. **Center turn control.** This prevents turn control from sending signals to servo units when you don't want it to do so.

3. **Turn all adjusting knobs on ACP to pointers up position.** Make sure pointers are not loose. Autopilot should be in approximate adjustment when knobs are at pointers up position.

4. **Turn SERVO-PDI switch ON.** This completes circuits to PDI and torque unit of stabilizer.

5. **Disengage bombsight clutch and engage autopilot clutch with PDI on center.** When you engage autopilot clutch with PDI on center it prevents directional panel from sending signals to servo units when they are not wanted.

6. **Operate airplane controls manually, observing tell-tale lights.** Move control surfaces through their extreme ranges of movement several times. This slides servo unit balance pot wipers over their respective pots and should clean off any dirt or dust that might be on pots. When controls are near streamlined position, tell-tale lights flicker. When

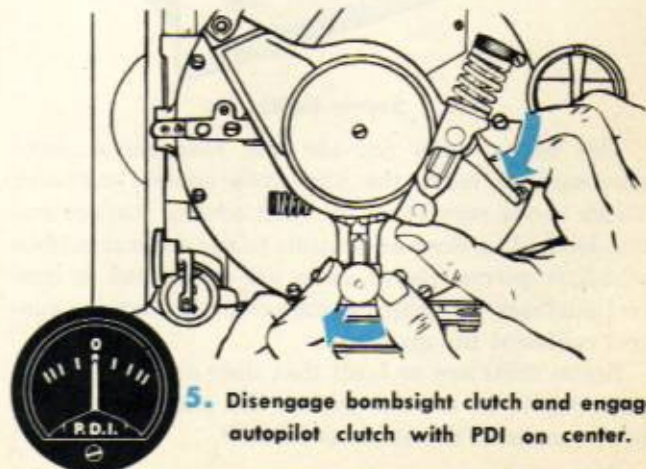

5. Disengage bombsight clutch and engage autopilot clutch with PDI on center.

controls are at extreme ends of their range, lights may go out as pot wipers are moved off pot winding. At any intermediate position one light or other should be on. If lights flicker at intermediate position, corresponding pot needs cleaning. Dirt between wipers and pots causes lights to flicker by breaking contact between wiper and pot.

7. Turn aileron, rudder, and elevator engaging switches ON, observing tell-tale lights. As you engage these switches, corresponding lights should come on, flicker, then go out as controls move into streamlined position. At first, lights glow because signals are being sent to restore controls to streamlined position. When servo units move controls to streamlined position signals cease and consequently lights go out.

8. Rotate each centering knob, observing controls. Check for proper control movement as you turn each knob clockwise, then counter-clockwise:

Aileron centering knob turned clockwise, control wheel turns right.

Rudder centering knob turned clockwise, rudder pedal moves forward.

Elevator centering knob turned clockwise, control column moves to rear.

9. Rotate turn control knob, observing controls. Check for proper control movement as you turn knob clockwise, then counter-clockwise. When you turn knob clockwise, controls move for right turn.

10. Disengage autopilot clutch and displace to each side, observing controls. Engage autopilot clutch. When you displace clutch to left stop, controls should move for right turn.

11. Turn autopilot master switch OFF. When you turn off master switch, all other switches that engage units of autopilot are turned off. This prevents running down airplane batteries. It also avoids danger of accidental control by autopilot during takeoff.

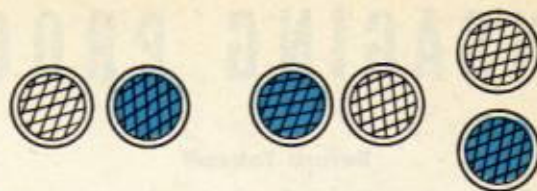

7. Turn aileron, rudder and elevator engaging switches ON, observing tell-tale lights.

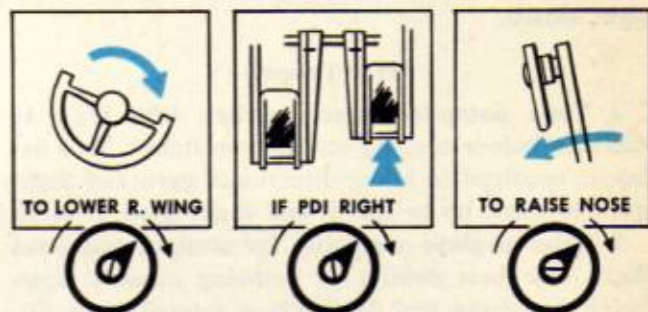

8. Rotate each centering knob, observing controls.

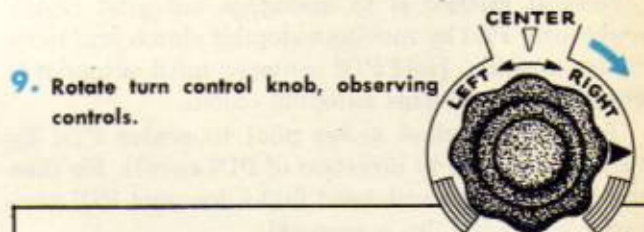

9. Rotate turn control knob, observing controls.

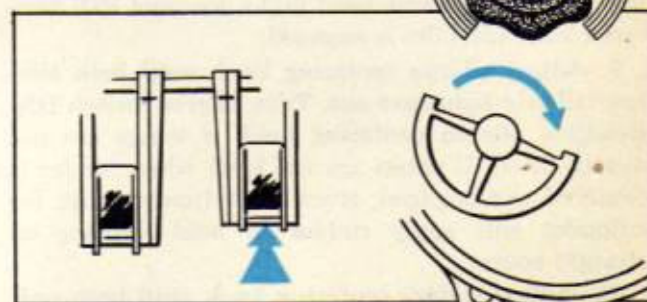

10. Disengage autopilot clutch and displace to each side, observing controls. Engage autopilot clutch.

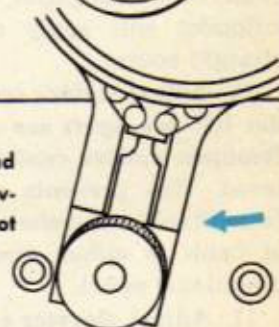

11. Turn autopilot master switch OFF.



6. Operate airplane controls manually, observing tell-tale lights.

ENGAGING PROCEDURE

Before Takeoff

1. Center turn control. Also make sure control transfer knob is at PILOT.
2. Turn adjusting knobs on ACP to pointers up position. Do this unless knobs are known to be properly adjusted.
3. Engage autopilot clutch and disengage bomb-sight clutch.

After Takeoff

4. Turn autopilot master switch ON. Wait 10 minutes before turning on other switches. This delay is required to allow directional gyro and flight gyro to come up to speed, and flight gyro to erect.
5. Trim airplane manually for straight and level flight. For best results on bombing mission, open bomb bay doors and fly bombing airspeed and altitude before trimming airplane.
6. Turn SERVO-PDI switch ON.
7. Turn tell-tale light switch ON.
8. Center PDI.

Normal method is to disengage autopilot clutch and center PDI by moving autopilot clutch arm to its center position. Hold PDI centered until autopilot is engaged, then engage autopilot clutch.

Alternate method is for pilot to center PDI by turning airplane in direction of PDI needle. He then resumes straight and level flight, keeping PDI centered until autopilot is engaged.

9. Adjust aileron centering knob until both aileron tell-tale lights are out. Turn aileron switch ON. Readjust aileron centering knob if wings are not exactly level. If wings are not level when rudder is centered and engaged, cross control may result, for autopilot will apply rudder to hold airplane on straight course.

10. Adjust rudder centering knob until both rudder tell-tale lights are out. Turn rudder switch ON. Readjust rudder centering knob if PDI is not centered. This prevents operation of erection cutout from directional panel. It also assures same amount of bank in either direction for turns made from directional panel.

11. Adjust elevator centering knob until both elevator tell-tale lights are out. Turn elevator switch ON. Readjust elevator centering knob if airplane does not maintain level flight.



5. Trim airplane manually for straight and level flight.

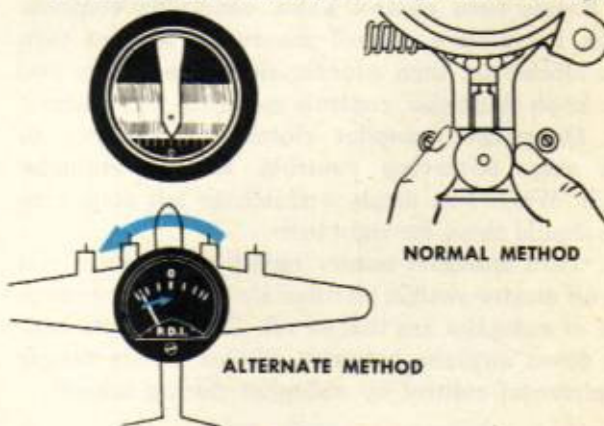

8. Center PDI.



9.-10.-11. Turn aileron, rudder, and elevator switches ON and adjust for straight and level flight.

FLIGHT ADJUSTMENTS

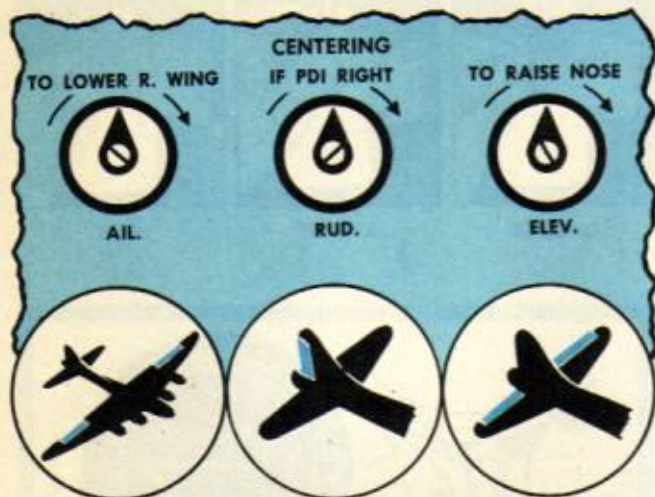

CENTERING ADJUSTMENT

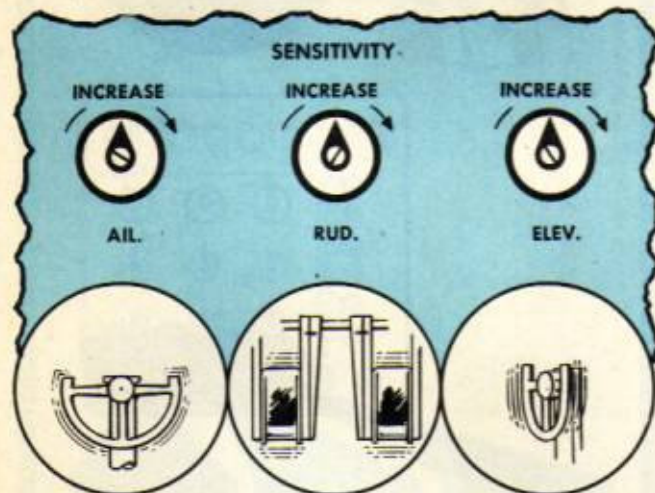

SENSITIVITY ADJUSTMENT

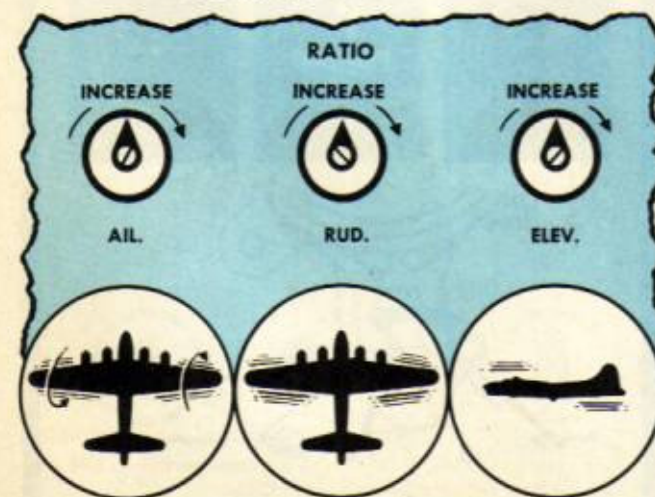

RATIO ADJUSTMENT

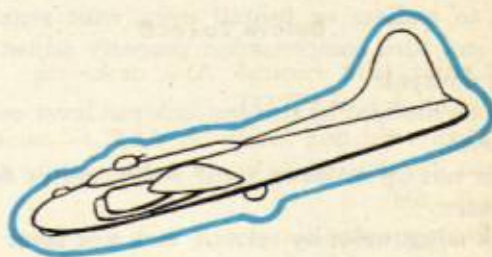

Centering

Centering knobs on the ACP are comparable to the trim tabs of the airplane. When flying under autopilot control, use centering knobs instead of mechanical trim tabs to compensate for slight changes in airspeed, center of gravity, or gross weight. When large changes in these flight conditions occur, you must disengage autopilot, re-trim mechanically and re-engage the autopilot. Never trim controls with mechanical trim tabs while autopilot is in operation. In this situation the trim tabs will not change the airplane's attitude because the autopilot counteracts their effect. If you were to move the trim tabs while the autopilot is engaged, and were to leave them in a changed position, when you disengaged the autopilot the trim tabs would suddenly become effective and produce a violent reaction.

Sensitivity

A pilot may apply a correction for even the slightest deviation (high sensitivity) or he may wait for a larger deviation before applying the correction (low sensitivity). High sensitivity provides maximum flight stability but it is possible to adjust sensitivity so high that the controls vibrate or chatter. To adjust sensitivity, turn knobs clockwise until controls chatter. Then turn them counter-clockwise until continuous chatter stops.

Ratio

A pilot may apply too much control in correcting a given deviation, thus causing overcontrol (high ratio), or he may apply too little control in correcting the deviation and produce too slow a recovery (low ratio). To adjust ratio, first turn knobs clockwise to produce overcontrol. Then, reduce ratio to retain quick recovery without overcontrol.

Ratio requires slight readjustment with any appreciable change of indicated airspeed. After any change of ratio, re-check centering.

Dashpot

Incorrect dashpot adjustment can cause the airplane to wallow or fishtail even with sensitivity, ratio, and turn compensation properly adjusted. To adjust dashpot:

Unlock dashpot by turning lock nut lever counterclockwise.

Turn nut up or down until wallowing or fishtailing ceases.

Lock adjustment by turning lock nut lever clockwise.



Turn Compensation

Make sure airplane is flying straight and level with proper adjustment of sensitivity and ratio. Then adjust turn compensation knobs in following manner:

Disengage autopilot clutch and move clutch arm slowly to extreme right or left.

Adjust aileron compensation knob to produce 18° bank, as indicated by artificial horizon.

Adjust rudder compensation knob for correct amount of rudder, no skid or slip, as indicated by inclinometer.

Ball must be in exact center.

Make final adjustments with both knobs to obtain perfectly coordinated turn with 18° bank.

Adjust elevator compensation knob to apply sufficient up-elevator to maintain altitude during turn.

Engage autopilot clutch at its extreme position and allow directional gyro to center PDI. This provides a check on the aileron ratio adjustment. If the wings level off too soon and the PDI stops short of center, the aileron ratio is too high. If the wings level off too slowly and the PDI overshoots center, the aileron ratio is too low.

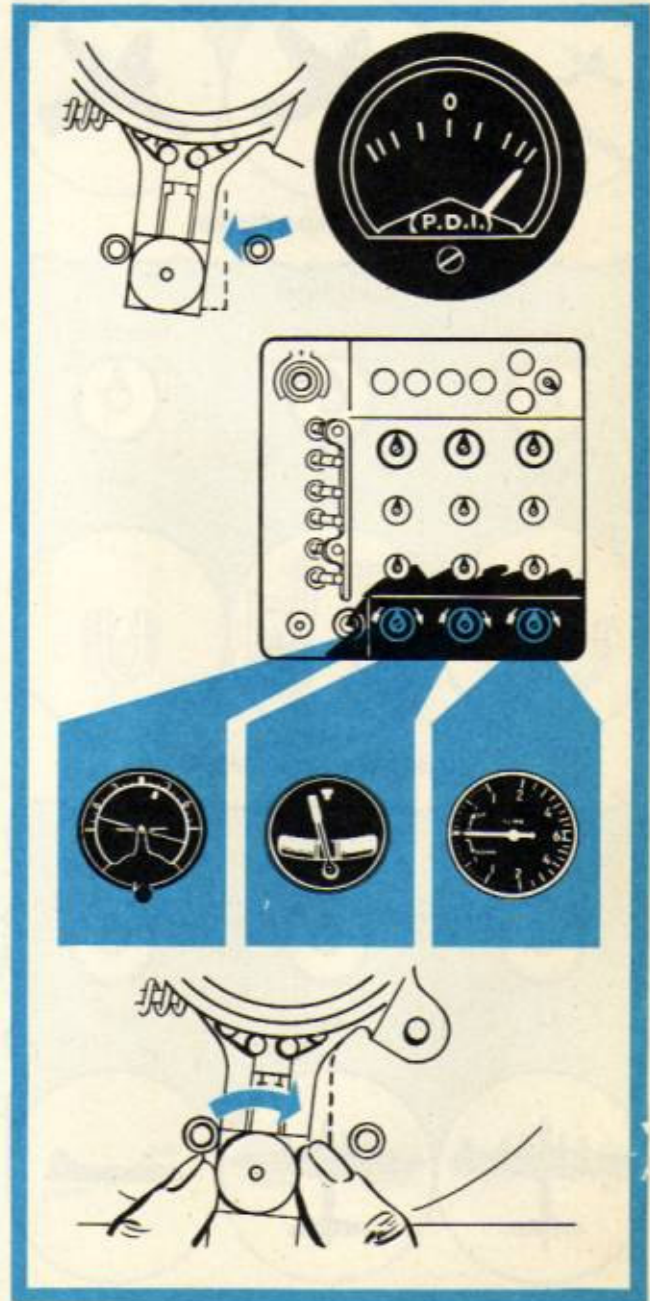

**REMEMBER—YOU MAKE FINAL
ADJUSTMENTS WITH BOTH
KNOBS FOR AN
18° BANK!**



Turn Control

The turn control seldom requires readjustment unless there is reason to believe that a previous adjustment has been changed. Before turning airplane with turn control, be sure airplane is flying straight and level with PDI at center. Rotate turn control knob slowly in direction of turn until pointer reaches lined region of dial or until you feel distinct resistance to further rotation.

At this setting the airplane should be in a coordinated 30° bank. If it is not, adjust turn control trimmers as follows:

Adjust aileron trimmer on autopilot control panel

until artificial horizon indicates 30° bank.

Adjust rudder trimmer until inclinometer indicates perfectly coordinated turn.

Adjust elevator centering knob until climb-and-dive indicator shows no gain or loss in altitude.

As airplane approaches desired new heading, slowly rotate turn control knob back to 0°. Time this return so pointer will reach 0° when desired heading is attained. (No signal is applied by the turn control when the pointer is at either 0° mark.) Hold pointer at 0° until airplane has leveled off on its new heading. Then center turn control pointer. If elevator centering was changed while in turn, readjust to maintain altitude while in level flight.



DIRECTIONAL PANEL TURNS

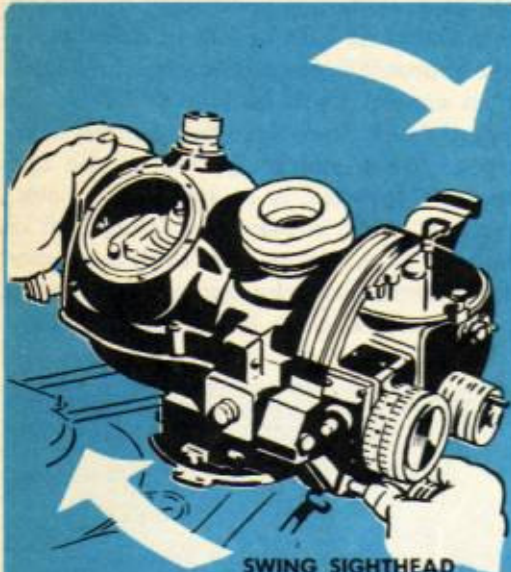

SWING SIGHTHEAD
OR
USE AUTOPILOT
CLUTCH TURN KNOB

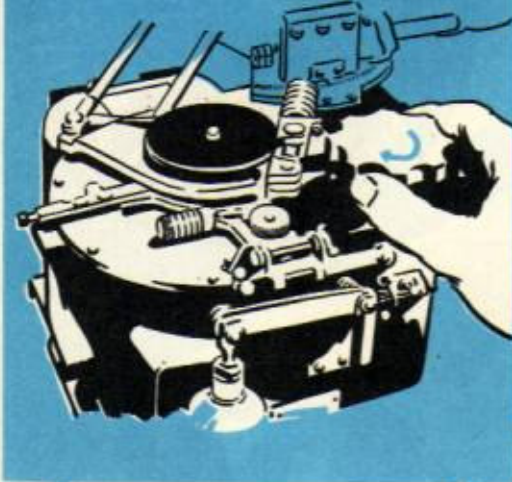

MANUAL
TURNS



BOMBSIGHT
TURNS

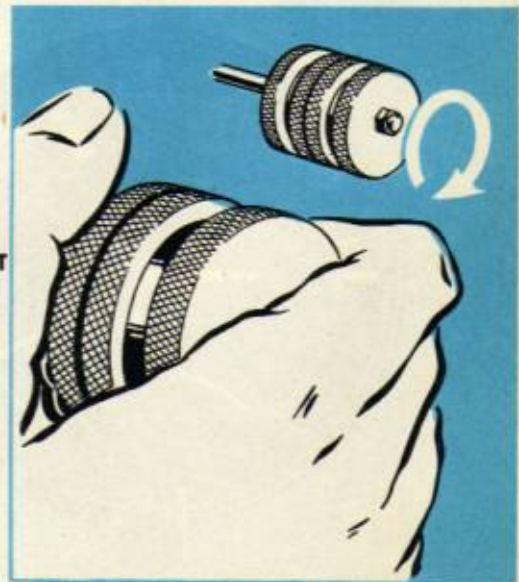

Manual Turns

When you want to turn airplane by means of autopilot clutch, disengage both it and bombsight clutch. Then, displace autopilot clutch either with autopilot clutch turn knob or by swinging bombsight. Smooth displacement produces smooth turn. When you move autopilot clutch to left, airplane turns to right, and vice versa. As airplane comes on desired heading, engage autopilot clutch or bombsight clutch and directional gyro will cause airplane to resume level flight. Autopilot then maintains this heading until autopilot clutch is again displaced.

Turns Through Bombsight

Bombsight course knobs control autopilot when on bombing run. To arrange this, you must engage bombsight clutch and disengage autopilot clutch. Then, when you turn both or either of course knobs clockwise airplane turns right. Bank depends on speed at which you turn course knob or knobs. By continuously turning knobs, you can keep airplane in turn. As it comes on desired heading, stop turning knobs. Directional gyro will maintain new heading.

MALADJUSTMENTS

AND HOW TO CORRECT THEM



PDI CENTERED, BALL NOT CENTERED,
IN STRAIGHT FLIGHT



BALL CENTERED, BUT PDI OFF

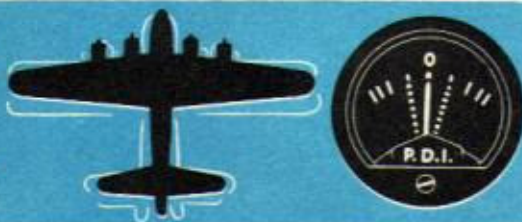

OVERCONTROL IN RUDDER AXIS



URNS COORDINATED IN ONE DIRECTION ONLY



LOSS OR GAIN OF ALTITUDE

LEARN THESE
MALADJUSTMENTS



1. **PDI centered, ball not centered, in straight flight.** This condition is the result of improper trimming, or centering with one wing low and opposite rudder applied to keep the airplane from turning. To correct:

Readjust aileron and rudder centering, or

Disengage both rudder and aileron switches and center PDI; then adjust centering and engage rudder and aileron switches.

2. **Ball centered, but PDI OFF.** To correct:

Readjust rudder centering, or

Disengage both rudder and aileron switches and center PDI; then adjust centering and engage rudder and aileron switches.

3. **Overcontrol in rudder axis.** This is caused by improper setting of ratio or dashpot. To correct:

Loosen locking collar and unscrew dashpot slowly.

Stop when overcontrol ceases, and re-lock.

If loosening dashpot does not eliminate overcontrol, reduce rudder ratio. After changing ratio, check rudder centering and rudder compensation adjustments. Then tighten dashpot to setting just below that which produces overcontrol.

4. **Turns coordinated in only one direction.** This occurs when airplane is not properly trimmed before starting turns. To correct:

Return to level flight and readjust aileron and rudder centering, or

Disengage rudder and aileron switches and re-trim manually before re-engaging.

5. **Loss or gain of altitude.**

In straight and level flight, correct with elevator centering knob.

In bombardier's turn, correct with elevator compensation knob and increase elevator ratio.

On bombing run, always maintain altitude with elevator centering knob.

FORMATION STICK

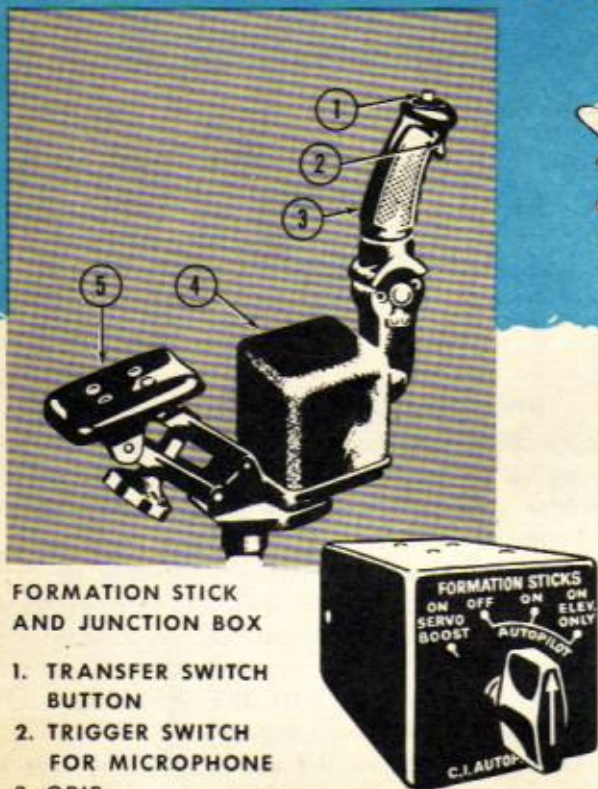

FORMATION STICK AND JUNCTION BOX

1. TRANSFER SWITCH BUTTON
2. TRIGGER SWITCH FOR MICROPHONE
3. GRIP
4. CONTROL MECHANISM
5. ARM REST

The formation stick permits the pilot or copilot to maneuver an airplane quickly though using the autopilot. It gives him, with a minimum of physical effort, the additional control of the airplane necessary for formation flying.

In airplanes equipped with this device, there are 2 formation sticks in the pilot's compartment. One is at the pilot's left, the other at the copilot's right. Only one stick is engaged at a time. A control switch button on top of each stick makes it possible to transfer control from one stick to another.

The extent to which a pilot using the formation stick can control his plane through the autopilot depends on **function selector** setting. For example:

1. When function selector is OFF, autopilot operates normally and formation stick has no control.
2. When the function selector is at ON SERVO BOOST, the formation stick directly controls the servo units of the autopilot. The airplane must then be flown as if it had no autopilot, and as if the formation stick were connected directly to the con-



trol cables. The ON SERVO BOOST position is the best setting for the function selector when the airplane is flying in a tight formation and constant maneuvering is necessary.

3. When the function selector is at ON, the stick functions just as the autopilot turn control knob does, except that it provides elevator control as well as aileron and rudder control. This setting is best for lone flying, loose formation flying, or when little maneuvering is necessary.

4. When the function selector is at ON ELEVATOR ONLY, the formation stick controls the attitude of the airplane with respect to the pitch axis only. Moving the stick sideways has no effect on the aileron and rudder controls. This position is used on the bombing run when the pilot wants to use the formation stick instead of the elevator centering knob to control altitude.

The formation stick also has a trigger switch connected in the microphone circuit. It operates whether or not the formation stick or autopilot is engaged. This switch permits the pilot or copilot to use his microphone without releasing formation stick.

Release switches are installed in all airplanes equipped with the formation stick. These switches enable the pilot or copilot to release all three servo units quickly, thereby returning the airplane to manual control. The switches are conveniently mounted on the airplane's control wheels. They are effective whether the formation stick is in use or not.

Caution

Airplane must be level before function selector is turned from one position to another.

PDI must be centered when function selector switch is turned to ON SERVO BOOST.

Autopilot turn control must not be used when function selector switch is at ON SERVO BOOST.



SECTION

6

M-SERIES BOMBSIGHT . . .

You need to have a good understanding of how the bombsight solves the bombing problem, and what happens inside it when you turn the various knobs.

Your success as a bombardier depends not only on your own skill but also on the mechanical condition of your equipment. Accordingly you have to be able to make sure that your bombsight is working properly, as you do in the preflight inspection. You also need to know how to give it the care necessary to keep it in good condition. Even though there are usually maintenance experts available, you should know how to make field inspections and adjustments.

There are a number of attachments and modifications which extend the bombsight's range of operations. With the glide bombing attachment you can bomb accurately in climbs and glides as well as in horizontal flight. Anti-glare lenses help overcome bad conditions of visibility. The trail spotting device increases accuracy in train bombing. The reflex sight makes it easier to pick up the target. Trail and disc speed modifications enable you to bomb at exceptionally high altitudes and airspeeds.

NOMENCLATURE AND OPERATION

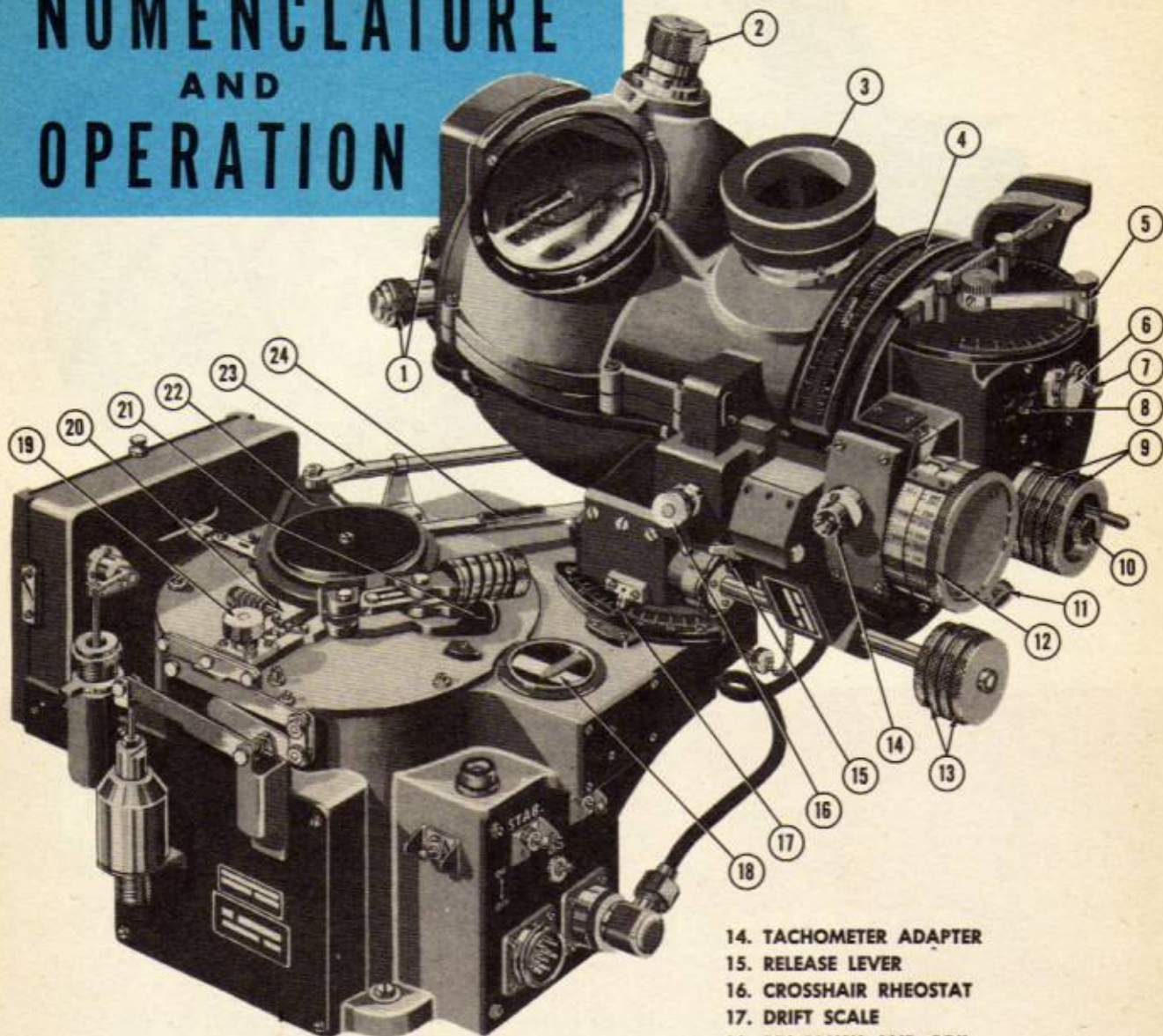

1. LEVELING KNOBS
2. CAGING KNOB
3. EYEPIECE
4. INDEX WINDOW
5. TRAIL ARM AND TRAIL PLATE
6. EXTENDED VISION KNOB
7. RATE MOTOR SWITCH
8. DISC SPEED GEAR SHIFT
9. RATE AND DISPLACEMENT KNOBS
10. MIRROR DRIVE CLUTCH
11. SEARCH KNOB
12. DISC SPEED DRUM
13. TURN AND DRIFT KNOBS

14. TACHOMETER ADAPTER
15. RELEASE LEVER
16. CROSSHAIR RHEOSTAT
17. DRIFT SCALE
18. PDI BRUSH AND COIL
19. AUTOPILOT CLUTCH ENGAGING KNOB
20. AUTOPILOT CLUTCH
21. BOMBSIGHT CLUTCH ENGAGING LEVER
22. BOMBSIGHT CLUTCH
23. BOMBSIGHT CONNECTING ROD
24. AUTOPILOT CONNECTING ROD

The bombsight has 2 main parts, **sighthead** and **stabilizer**. The sighthead pivots on the stabilizer and is locked to it by the dovetail locking pin. The sighthead is connected to the directional gyro in the stabilizer through the **bombsight connecting rod** and the **bombsight clutch**.

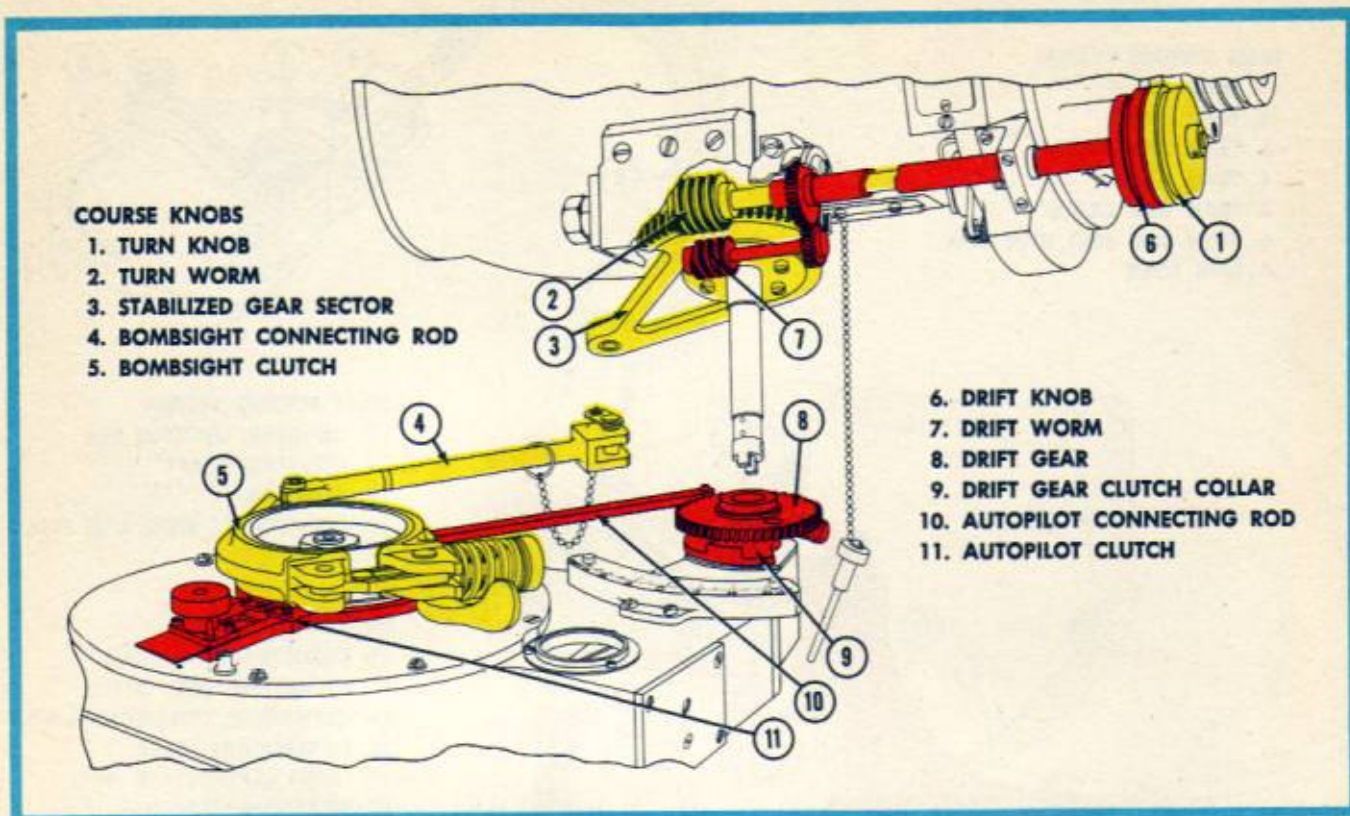

SETTING UP COURSE

To set up course with the bombsight you put your line of sight on the target with the **turn knob**. With the **drift knob** you turn the airplane into the wind to kill drift. As you do this, the bombsight automatically solves for crosstrail and directs the airplane on its proper course, upwind of the target.

Turn Knob

The turn knob is on the same shaft as the **turn worm**. The turn worm meshes with the **stabilized gear sector**.

The stabilized gear sector is connected to the bombsight clutch by means of the bombsight connecting rod. The turn worm housing is part of the sighthead. Thus when the bombsight clutch is engaged the directional gyro is linked to the sighthead and holds it stable as the airplane yaws.

When you use the turn knob the turn worm walks around the stabilized gear sector. This turns the sighthead on the stabilizer. At the same time the **PDI brush** moves through the same angle as the sighthead. When the pilot or autopilot takes out the PDI correction the airplane turns on a new heading

and the sighthead and stabilizer return to the same relation as before.

Drift Knob

Turning the drift knob turns the **drift worm**. The drift worm meshes with the **drift gear**. The PDI brush is mounted on the drift gear clutch collar, which grips the drift gear hub. Thus when you turn the drift knob you displace the PDI brush. You do this without turning the sighthead on the stabilizer. Therefore when the pilot or autopilot takes out the PDI correction the airplane and stabilizer turn under the sighthead. The angle thus set up between sighthead and stabilizer is the drift angle. You read it in degrees on the drift scale of the stabilizer.

If you attempt to move the PDI brush beyond the limit of its range, the drift gear clutch slips and prevents damage to the mechanism. When the autopilot clutch is engaged it locks the PDI brush to the directional gyro. Consequently you must have the autopilot clutch disengaged when on a bombing run.

You can use the turn knob correctly by itself. When you use the drift knob, however, you **double grip**. Double gripping moves the line of sight toward the target and kills drift at the same time.

TRAIL SETTING SYSTEM

- 1. TRAIL PLATE
- 2. TRAIL ARM
- 3. TRAIL ARM PINION
- 4. TRAIL RACK
- 5. TRAIL BELL CRANK
- 6. PUSH ROD AND LINK ROD
- 7. LINK FORK

DRIFT SETTING SYSTEM

- 8. DOVETAIL LOCKING PIN
- 9. DOVETAIL SHAFT
- 10. DOVETAIL
- 11. CONCENTRIC STUD AND DISC

CROSSTRAIL SYSTEM

- 12. CROSSTRAIL CARRIAGE
- 13. CROSSTRAIL BELL CRANK
- 14. CROSSTRAIL CONNECTING ROD
- 15. DIFFERENTIAL LEVER
- 16. GYRO CONNECTING ROD
- 17. TELESCOPE CRADLE

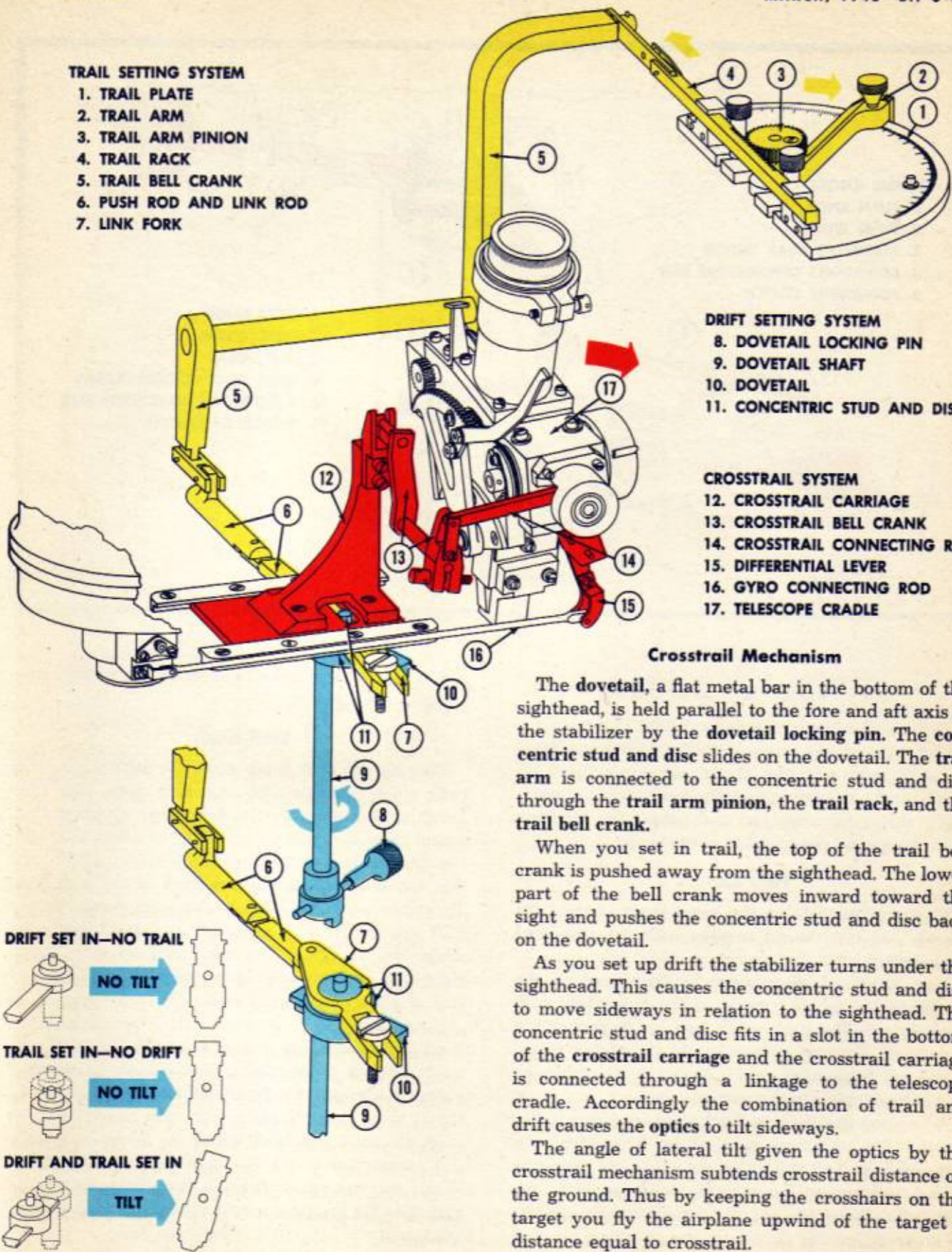

Crosstrail Mechanism

The dovetail, a flat metal bar in the bottom of the sighthead, is held parallel to the fore and aft axis of the stabilizer by the dovetail locking pin. The concentric stud and disc slides on the dovetail. The trail arm is connected to the concentric stud and disc through the trail arm pinion, the trail rack, and the trail bell crank.

When you set in trail, the top of the trail bell crank is pushed away from the sighthead. The lower part of the bell crank moves inward toward the sight and pushes the concentric stud and disc back on the dovetail.

As you set up drift the stabilizer turns under the sighthead. This causes the concentric stud and disc to move sideways in relation to the sighthead. The concentric stud and disc fits in a slot in the bottom of the crosstrail carriage and the crosstrail carriage is connected through a linkage to the telescope cradle. Accordingly the combination of trail and drift causes the optics to tilt sideways.

The angle of lateral tilt given the optics by the crosstrail mechanism subtends crosstrail distance on the ground. Thus by keeping the crosshairs on the target you fly the airplane upwind of the target a distance equal to crosstrail.

APPARENT PRECESSION

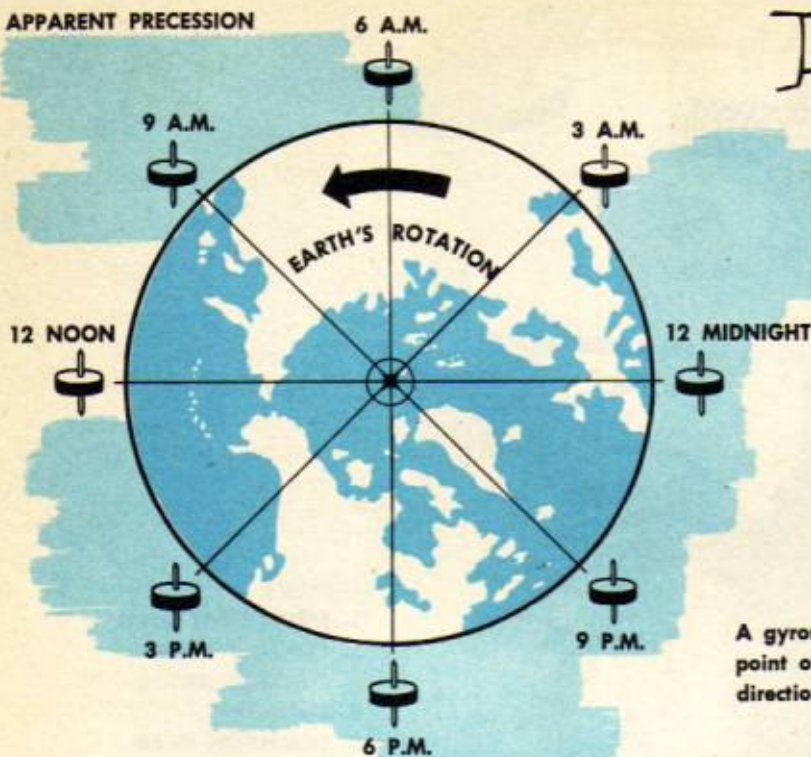

Bombsight Gyroscopes

The directional gyro in the stabilizer and the vertical gyro in the sighthead hold the optics in a steady fixed position relative to the earth. These gyros are simply flywheels, or rotors, spinning at the rate of about 7800 rpm. The main characteristics of gyroscopes are rigidity and precession.

A gyroscope tends to hold a fixed position in space. The strength or amount of this **rigidity** can be increased by increasing the weight of the rotor. It can also be increased by distributing the weight of the rotor as far from the spin axis as possible. In operating the bombsight, however, the main thing to remember is that rigidity increases as the speed of the rotor increases. This means that if either of your gyros runs slowly due to low voltage or for any other reason, the gyro loses some of its stability.

Rigidity causes the spin axis of a gyro to remain pointed in a fixed direction. However, as the earth turns under the gyro the axis of the gyro **appears** to tilt.

Suppose you have a gyro at the equator. At noon its spin axis is horizontal. At 6 p.m. the axis is vertical, and by midnight the gyro is upside down from its noon position. It appears that the gyro has turned

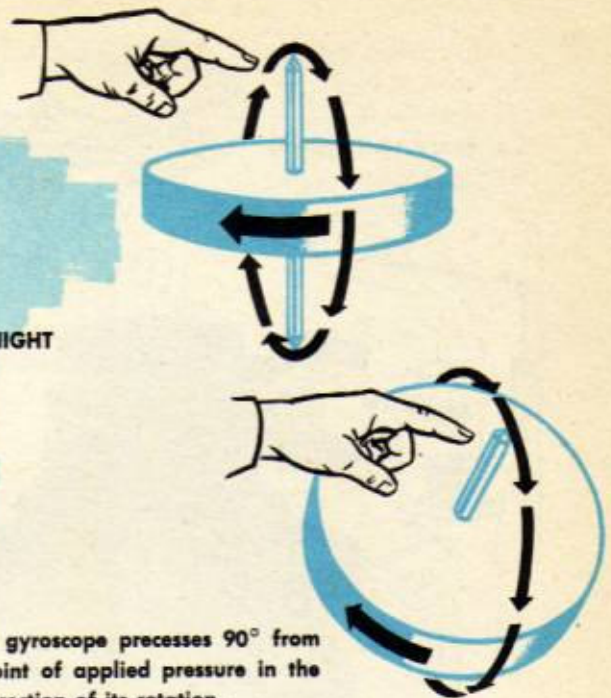

A gyroscope precesses 90° from point of applied pressure in the direction of its rotation.

INDUCED PRECESSION

over. Actually it is the earth that has turned. This movement of the earth in relation to the gyro is called **apparent precession**.

The greatest amount of apparent precession is at the equator. There, a gyro apparently precesses 1° , or 17.45 mils, in 4 minutes. You can calculate the amount of apparent precession that takes place in 4 minutes at any latitude by multiplying 17.45 mils by the cosine of the latitude.

To change the position of a gyro you apply force to overpower its rigidity. The resulting motion of the gyro is called **induced precession**. The gyro's spin axis does not move in the direction of the applied force, as you would expect. Instead it moves at a right angle to the applied force and in the direction of the gyro's rotation. This is known as the **law of precession**.

Suppose you have a gyro that is spinning clockwise. If you push the top of the spin axis toward the 3 o'clock position the top of the gyro tilts toward the 6 o'clock position.

When you use the **leveling knobs** on the sighthead you apply force to the gyro and thus use the law of precession. Similarly the **torque unit** in the stabilizer uses induced precession to keep the directional gyro in position.

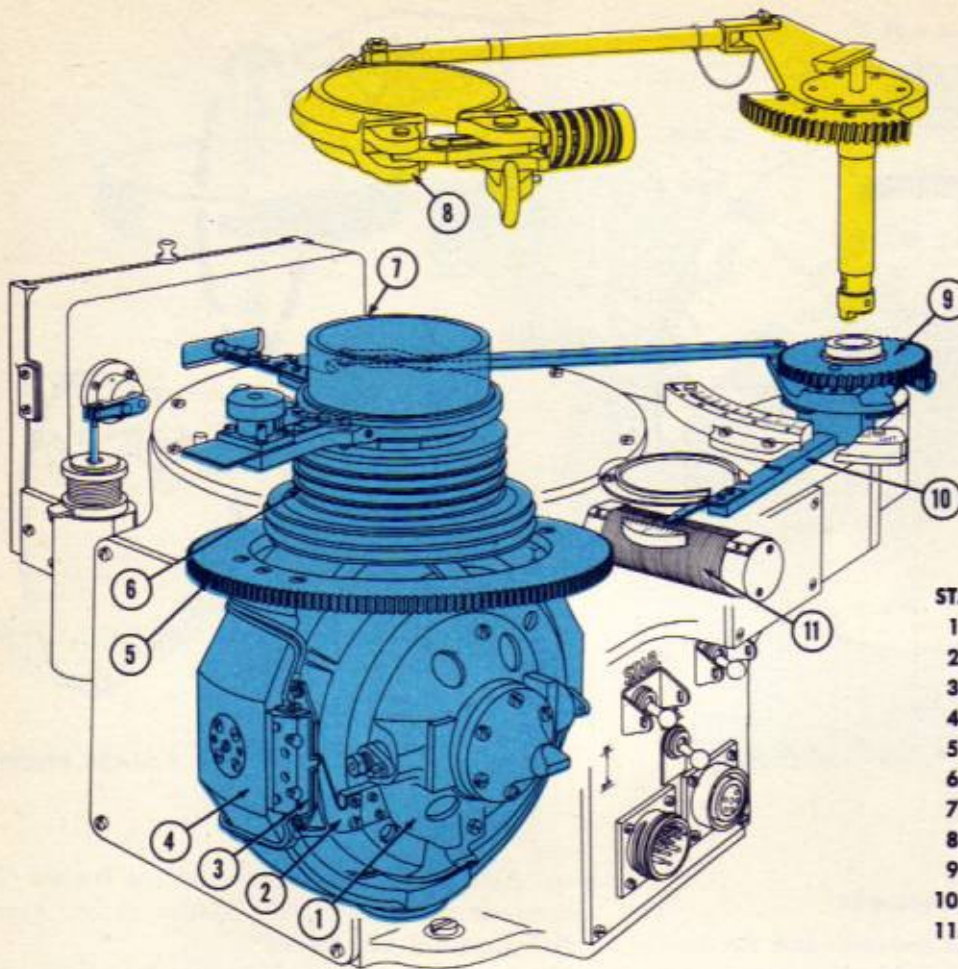

STABILIZER

- 1. DIRECTIONAL GYRO
- 2. CONTACT BRUSH
- 3. CONTACT SECTOR
- 4. CARDAN
- 5. PRECESSION GEAR
- 6. SLIP RING ASSEMBLY
- 7. BOMBSIGHT CLUTCH DRUM
- 8. BOMBSIGHT CLUTCH COLLAR
- 9. DRIFT GEAR CLUTCH
- 10. PDI BRUSH
- 11. PDI COIL

TORQUE UNIT

- 1. TORQUE MOTOR
- 2. CLAPPER MAGNETS
- 3. CLAPPER ARMS
- 4. PIVOT PINS
- 5. CLUTCH DISCS
- 6. CORK FACINGS
- 7. CLUTCH DRIVE GEARS

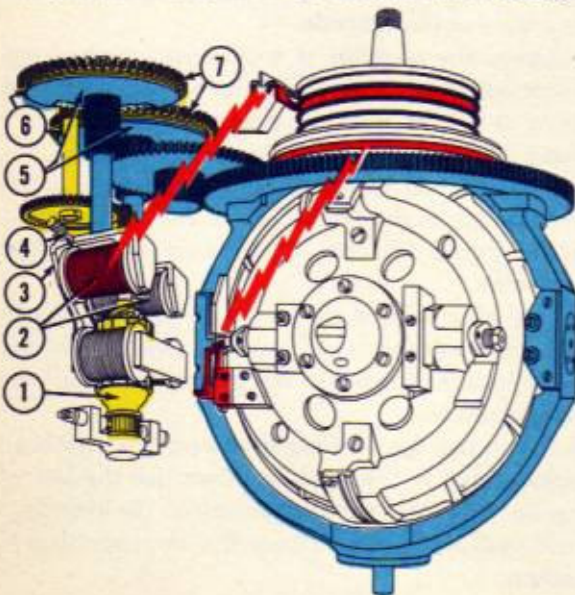

Directional Gyro

The directional gyro is mounted in its housing in such a way that its spin axis is horizontal. The housing pivots in a metal ring called the **cardan**. The cardan is mounted in the stabilizer case on vertical gudgeon bearings.

The upper cardan gudgeon extends up through the stabilizer case. The clutch drums fit on this extension.

The motor in the directional gyro is series wound. When first turned on it throws an exceptionally high load on the electrical system. Current to it is controlled by the switch marked STAB. Always allow 3 minutes after turning this switch ON before turning on any others.

Torque Unit

When the directional gyro tilts out of the horizontal it loses some of its stability in yaw. The function of the torque unit is to keep the gyro horizontal. When the gyro axis moves so that it is not parallel to the bottom of the stabilizer case a signal goes to

the torque unit. The torque motor then applies force to the **precession gear** on the gyro cardan. This force precesses the gyro back to its correct position.

The torque motor runs all the time that the switch marked **SERVO** is ON. However it is only when the gyro is out of the horizontal that the motor transmits force to the precession gear.

If you turn on the **SERVO** switch before the directional gyro is running up to speed, the torque unit may precess the gyro violently and thus damage it.

SOLVING FOR RANGE

The bombsight solves for the point of release by computing the dropping angle. Three factors are involved in the computation—disc speed, trail, and groundspeed.

Disc speed and trail you set in the sight before the bombing run. You get values for both of these from your bombing tables. The disc speeds in the tables were obtained by dividing the bombsight constant, 5300, by ATF. You solve for the third factor, groundspeed, when you synchronize for rate.

The parts of the sighthead used in solving for range are the **optical system**, the **vertical gyro**, and the **rate end**. The rate end contains the disc drive, rate, trail, and mirror drive systems.

Optical System

The optical system consists of the **telescope** and the **mirror** mounted in the telescope cradle. The mirror pivots on lateral bearings. As you approach the target the mirror rotates. When you are synchronized this rotation of the mirror is the exact amount needed to keep your line of sight on the target.

CROSSHAIR LIGHTING

1. RHEOSTAT
2. RHEOSTAT KNOB
3. BULB
4. MIRROR AND ADJUSTING ARM
5. CROSSHAIRS

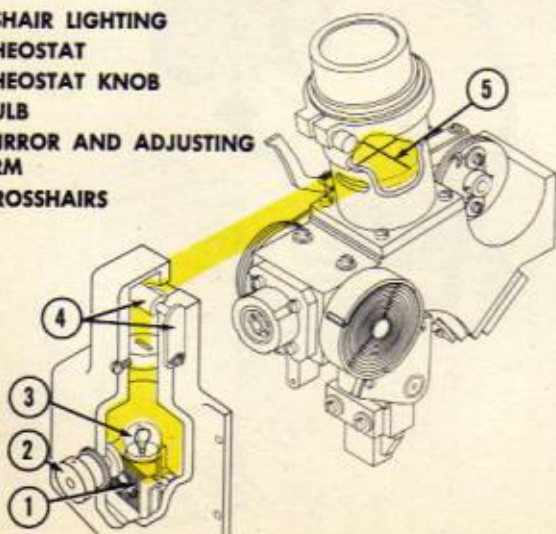

Crosshairs are etched on one of the lenses of the telescope. A small bulb lights them indirectly. You use the **crosshair rheostat** on the rear of the sighthead to control the brightness of the light.

Vertical Gyro

The vertical gyro stabilizes the optics in roll and pitch. It also furnishes the vertical reference the bombsight must have to calculate the release point accurately. When the bubbles in the 2 levels on the gyro housing are centered the spin axis is vertical. By means of the leveling knobs you can apply force to gyro to precess it either laterally or fore and aft.

Each leveling knob is actually 2 knurled knobs mounted on the same shaft. The small outer knob delivers to the gyro the full force of applied pressure and torque. You use this knob for large, fast corrections. The large inner knob applies its force to the gyro through the small coil spring inside the knob. This spring limits the force the inner knob delivers to the gyro. Accordingly, you use the inner knob for small corrections. The second and larger spring inside the inner leveling knob pushes the knobs away from the gyro when you are not using them.

Always pull the leveling knobs out after using them. If they remain in they may cause continued precession.

When you are not on a bombing run it is necessary to keep the gyro caged. This prevents it from tumbling and being damaged. To cage the gyro, push down with steady pressure on the **caging knob** at the top of the sighthead. An inverted cone on the lower end of the caging knob shaft then catches and holds the **gyro locking pin** which extends upward from the gyro housing.

GYRO LEVELING

1. FORE AND AFT LEVELING KNOB
2. FRICTION DISC
3. GYRO HOUSING
4. LATERAL LEVELING KNOB
5. FRICTION CONE DISC
6. CARDAN

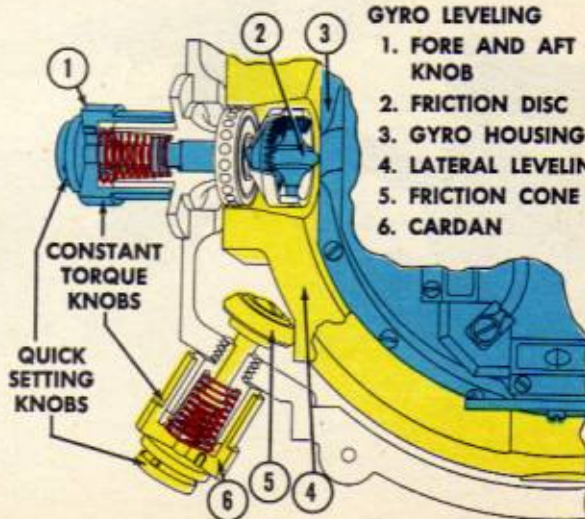

Disc Drive System

The disc is driven by the rate motor. To change its speed you turn the disc speed drum.

Current to the motor passes through a pair of breaker points. A governor on the motor shaft tends to pull these points apart as the speed of the motor increases. Coil springs inside the disc speed drum tend to hold the points together. When you set in disc speed you adjust the tension on the springs so that they hold the points together until the motor just reaches the required speed. At that speed the governor forces the points apart and breaks the circuit. As the motor slows below the required speed, the points come together and the circuit is restored. This action is so rapid that it holds the disc speed within $\frac{1}{10}$ rpm of the desired speed.

The tension the disc speed drum springs exert varies at different temperatures and under different conditions of wear. Accordingly you cannot depend on the scales marked on the disc speed drum. It is always necessary to check the disc speed by using tachometer or stop watch after reaching your bombing altitude.

The rate motor drives the disc through a set of gears that delivers either of 2 ranges of speed. You set the disc speed gear shift to the front for disc speeds of from 102 to 245 rpm, and to the rear for disc speeds of from 245 to 590 rpm.

Rate System

A roller with its edge against the disc picks up drive from the disc and transmits it through the mirror drive system to the mirror.

When you turn the rate knob, you do 3 things:

1. Position roller on disc.
2. Position dropping angle index.
3. Position automatic release points.

When the roller is near the center of the disc it turns slowly. As it is moved farther from the center it turns more rapidly. When you synchronize you move the roller and place it on the disc at just the point where it will keep the lateral crosshair on the target. At that point the roller turns at a speed proportional to groundspeed and its distance from the center of the disc is proportional to whole range.

The roller is in a carriage which moves up or down on the spindle screw. Turning the rate knob

DISC DRIVE SYSTEM

1. RATE MOTOR SWITCH
2. RATE MOTOR
3. GOVERNOR
4. DISC SPEED DRUM
5. DISC SPEED DRUM SPRINGS

6. BREAKER ARM
7. BREAKER POINTS
8. DISC SPEED GEAR SHIFT
9. CLUTCH
10. DISC
11. TACHOMETER ADAPTER

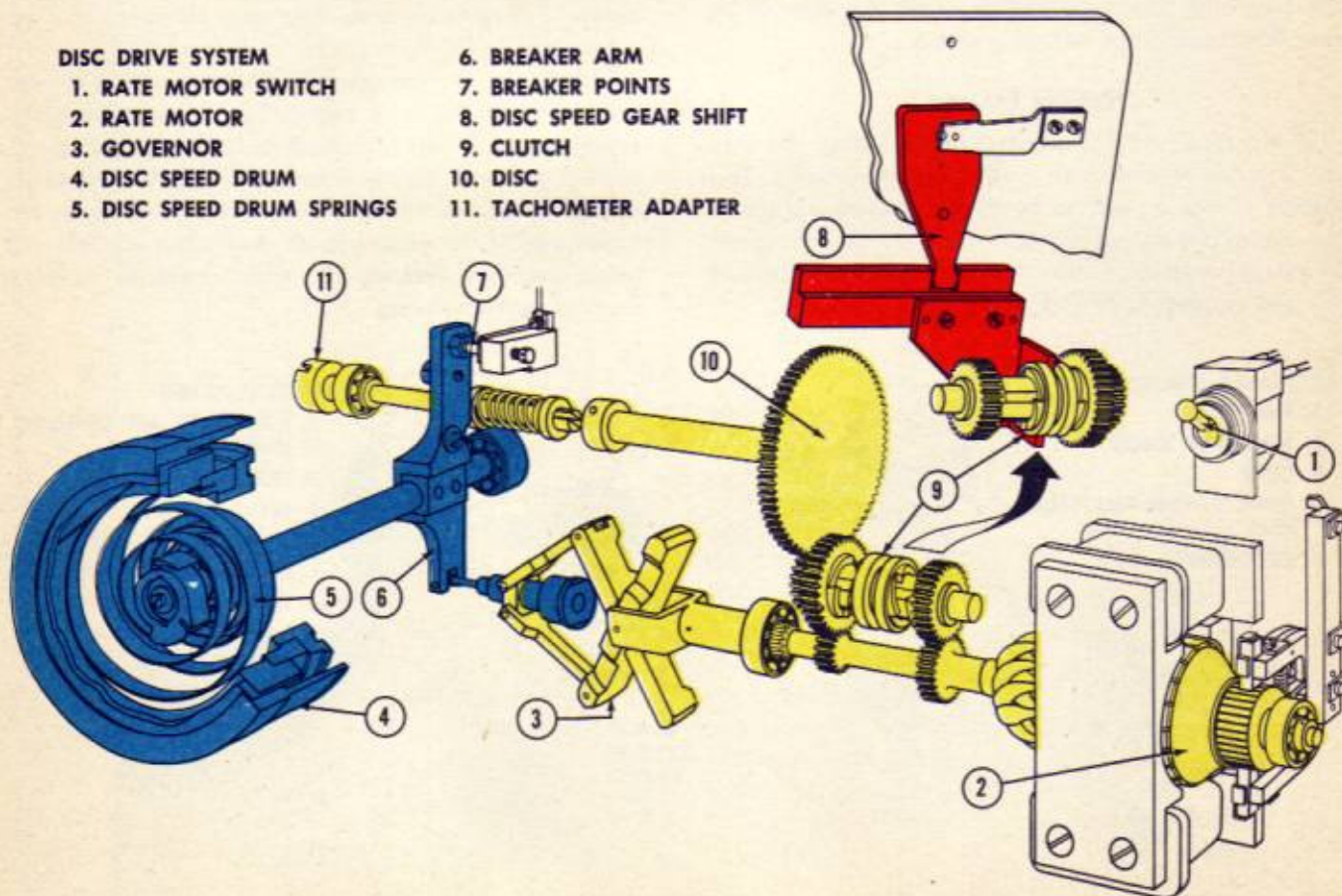

turns this spindle screw, thus moving the **roller carriage** up or down, and at the same time rotates the **rate quadrant**. The **dropping angle index** is on the rate quadrant. You see the dropping angle index in the right side of the index window, next to the **tangent scale**. On the scale you read the tangent of the dropping angle.

The **automatic release points** are also on the rate quadrant. As the sighting angle index comes to coincide with the dropping angle index, a notch in the mirror drive quadrant allows the points to come together provided the **release lever** is raised. This completes an electrical circuit to the bomb racks and a bomb is released. When the release lever is down it prevents the automatic release points from coming together.

Trail System

When you move the **trail arm** you turn the **nut gear** that works up and down on a threaded bearing block. The spindle screw is free to slide up or down inside this block. When you set in trail you lift the entire roller carriage and spindle screw assembly without turning it and thus **without moving the rate quadrant**. This moves the roller up from the center of the disc a distance proportional to trail. Accordingly this distance is subtracted from any distance you might later move the roller from the center of the disc. Thus trail is subtracted from any whole range you synchronize for.

Consequently, when you synchronize with the rate knob, you position the roller a distance from the center of the disc proportional to whole range, but you rotate the rate quadrant only through the actual range angle. This rotation of the rate quadrant sets up a dropping angle that subtends, as it should, the actual range. In this manner you find the correct release point.

Never force the trail arm if it appears to be sticking. To do so may set in pre-set trail. With a large dropping angle in the sight the roller carriage may strike its upper limit before you have moved the trail arm through its full range.

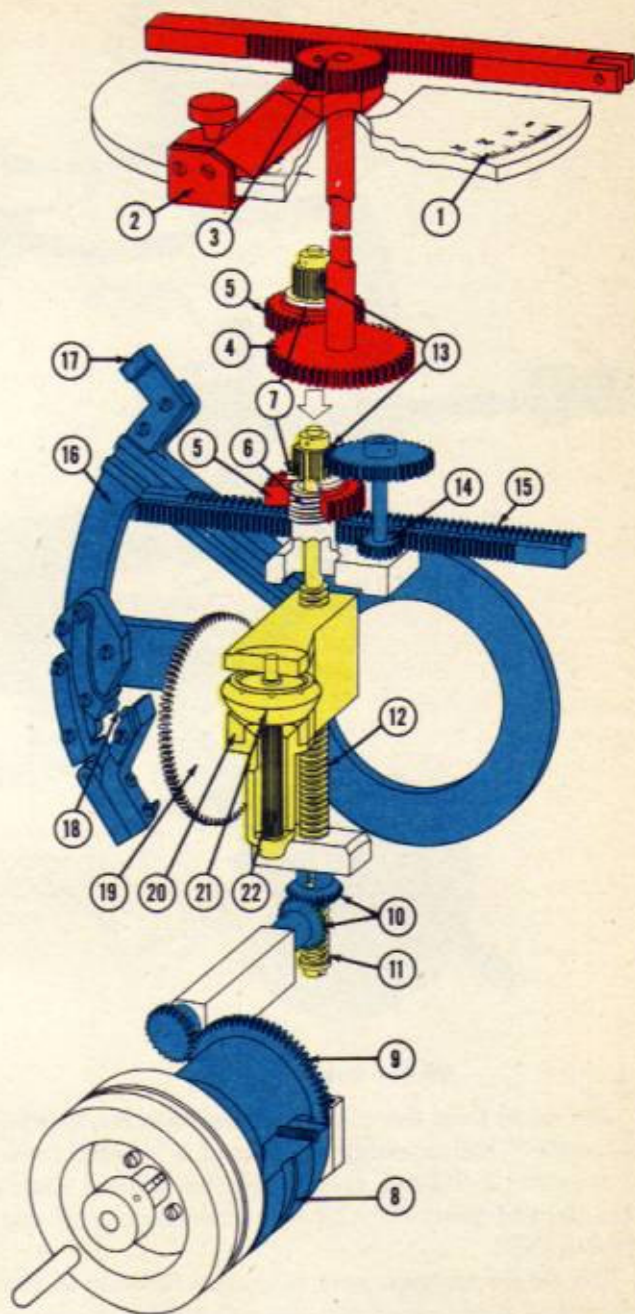

TRAIL SETTING SYSTEM

1. TRAIL PLATE
2. TRAIL ARM
3. TRAIL ARM PINION
4. TRAIL SETTING GEAR
5. NUT GEAR
6. THREADED BEARING BLOCK
7. THRUST WASHER

RATE SETTING SYSTEM

8. RATE KNOB
9. RATE KNOB GEAR
10. RATE BEVEL GEARS
11. THRUST SPRING
12. SPINDLE SCREW
13. SPINDLE SCREW PINION
14. RATE RACK PINION
15. RATE RACK

16. RATE QUADRANT

17. DROPPING ANGLE INDEX
18. AUTOMATIC RELEASE POINTS

DISC AND ROLLER ASSEMBLY

19. DISC
20. ROLLER CARRIAGE
21. ROLLER
22. SPLINE GEAR

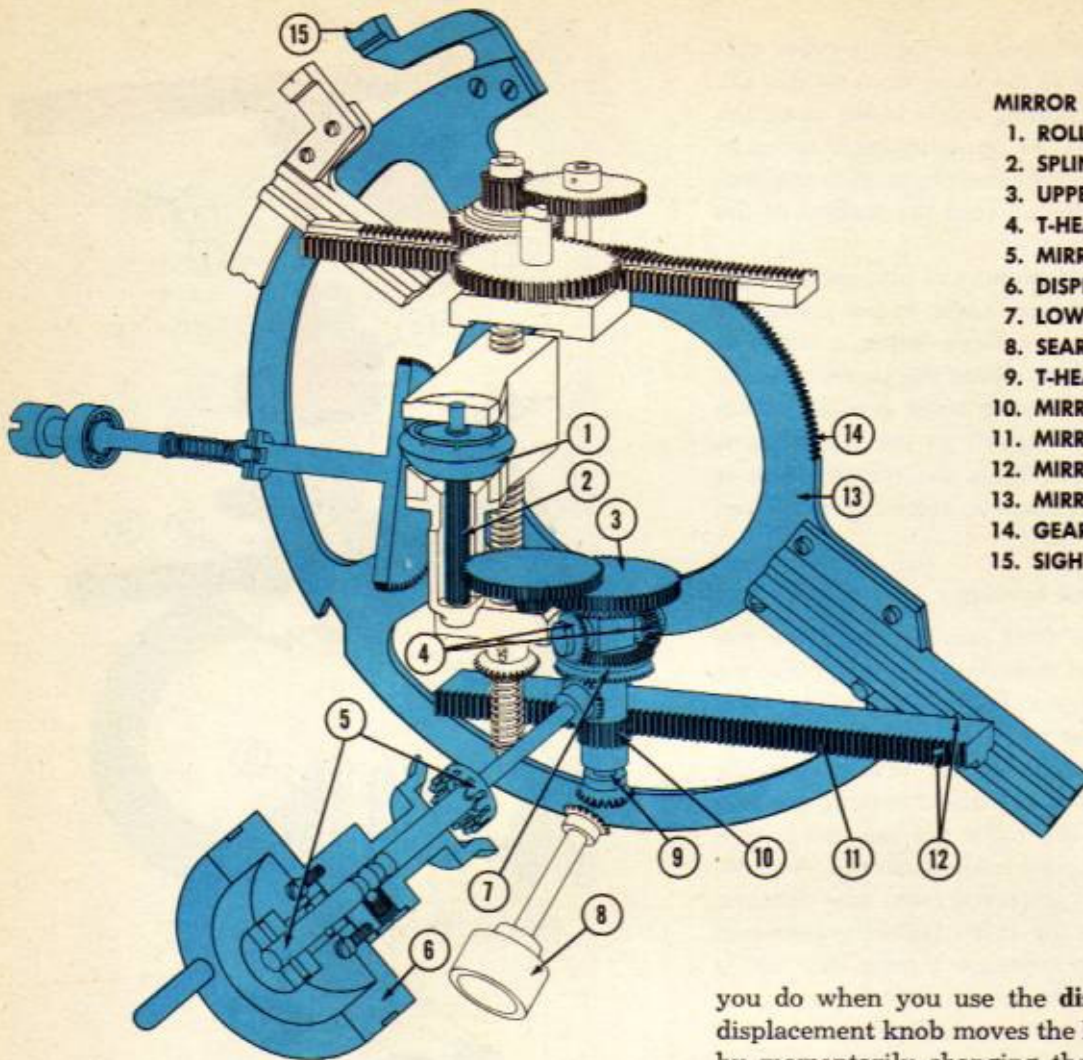

MIRROR DRIVE SYSTEM

1. ROLLER
2. SPLINE GEAR
3. UPPER TRACTION GEAR
4. T-HEAD GEARS
5. MIRROR DRIVE CLUTCH
6. DISPLACEMENT KNOB
7. LOWER TRACTION GEAR
8. SEARCH KNOB
9. T-HEAD SHAFT
10. MIRROR DRIVE RACK PINION
11. MIRROR DRIVE RACK
12. MIRROR DRIVE RACK STUD
13. MIRROR DRIVE QUADRANT
14. GEARED SECTOR
15. SIGHTING ANGLE INDEX

Mirror Drive System

The drive from the roller goes through the **T-head assembly**. This assembly consists of 2 beveled traction gears, 2 T-head gears, and the T-head shaft. The **T-head gears** idle on the crossmember of the **T-head shaft**.

The **upper traction gear** is geared directly to the roller and turns whenever the roller does. A pinion on the same shaft as the **mirror drive clutch** meshes with the **lower traction gear**. When you engage the mirror drive clutch you lock the lower traction gear so it cannot turn. **Always engage the mirror drive clutch by working the knob in**, not by forcing it in.

With the mirror drive clutch engaged the T-head gears are forced to walk around the lower traction gear. In this way the drive from the roller is transmitted to the T-head shaft.

You can speed up or slow down the T-head shaft by turning the lower traction gear. That is what

you do when you use the **displacement knob**. The displacement knob moves the line of sight fore or aft by momentarily changing the speed of the T-head shaft.

The **search knob** is geared directly to the bottom of the T-head shaft. It gives you rapid fore and aft displacement of the line of sight through the full 70° range. You can turn the search knob only when the mirror drive clutch is disengaged.

The **mirror drive rack pinion** on the T-head shaft drives the **mirror drive rack**. The stud at the end of the mirror drive rack slides in a slot in the **mirror drive quadrant**. As the rack moves, the movement of the stud rotates the mirror drive quadrant. At the same time the stud slides closer to the center of the quadrant. Accordingly it rotates the quadrant at the increasing rate needed to keep the line of sight on the target as you go down the run.

The **geared sector** on the mirror drive quadrant drives the **first sheave gear**. This turns the **first sheave**. As the first sheave turns, it winds the **mirror drive cable** on it. The resulting motion of the cable rotates the mirror on its axis.

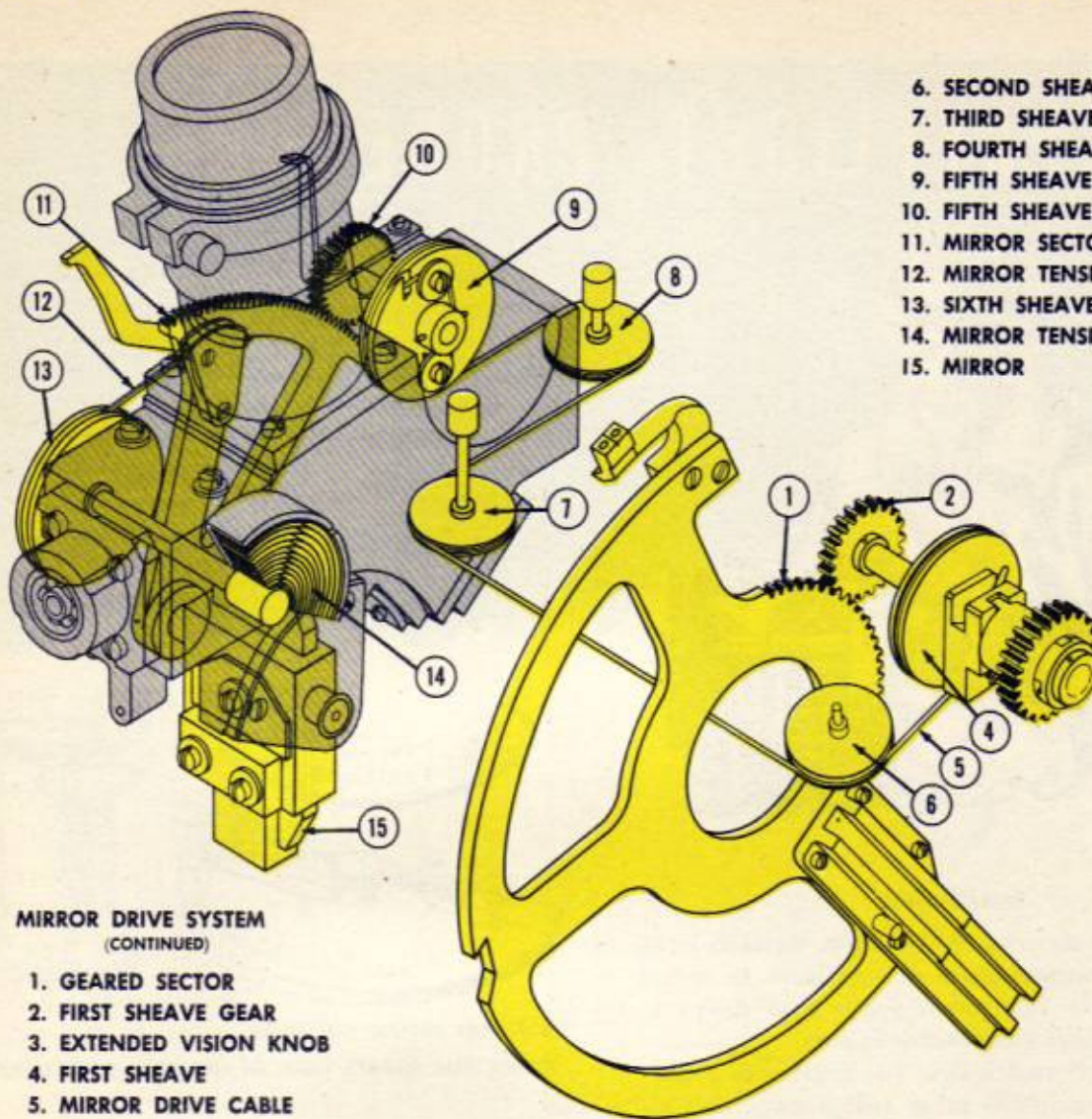

- 6. SECOND SHEAVE
- 7. THIRD SHEAVE
- 8. FOURTH SHEAVE
- 9. FIFTH SHEAVE
- 10. FIFTH SHEAVE GEAR
- 11. MIRROR SECTOR
- 12. MIRROR TENSION CABLE
- 13. SIXTH SHEAVE
- 14. MIRROR TENSION SPRING
- 15. MIRROR

**MIRROR DRIVE SYSTEM
(CONTINUED)**

- 1. GEARED SECTOR
- 2. FIRST SHEAVE GEAR
- 3. EXTENDED VISION KNOB
- 4. FIRST SHEAVE
- 5. MIRROR DRIVE CABLE

The sighting angle index is on the mirror drive quadrant. You see it in the left side of the index window, next to the degree scale. On this scale you can read the sighting angle at any time.

When the sighting angle index reaches its upper limit the pinion that drives the mirror drive rack begins to slip on the last tooth of the rack. As this slipping continues it causes unnecessary wear and puts extra strain on the mirror drive cable. Accordingly you should disengage the mirror drive clutch or turn the rate motor switch OFF before the sighting angle index reaches the upper end of its scale.

The extended vision knob enables you to get more than the normal 70° forward vision. When you push in on the extended vision knob you disengage the first sheave from the first sheave gear. Turning the knob counter-clockwise unwinds extra cable from the first sheave and allows you 20° additional for-

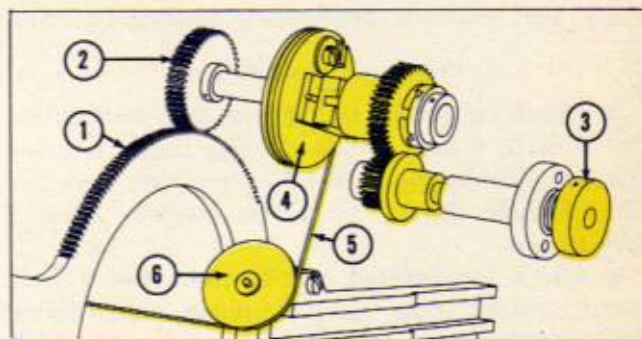

ward vision. Rolling in extended vision does not move the sighting angle index.

You cannot synchronize with extended vision in. If you use extended vision and forget to return the extended vision knob to its normal position your bomb will not be released at the proper point.

PREFLIGHT PROCEDURE



You must make a preflight inspection of the bombsight before every mission. Although the sight stands up well under normal conditions, malfunctions do occur. A careful preflight can make the difference between a mission's success and failure.

Call the maintenance department if you find a malfunction while making the preflight.

Installation

1. Check for security of clevis pin, dovetail locking pin, and cannon plugs. If you have to install sighthead, lower sight stem gently into sleeve to avoid burring drift worm and drift gear.

2. Turn STAB switch ON. You must wait 3 minutes before turning any other switches on. This allows directional gyro enough time to gain running speed and prevents overloading electrical circuit.

Crosstrail Mechanism

3. Check for pre-set trail in crosstrail mechanism. Set 0 drift, 0 trail, small sighting angle. Remove dovetail locking pin. Rotate dovetail shaft. Fore and aft crosshair should not move. Replace dovetail locking pin.

4. Check for dovetail misalignment. Set 0 drift, small sighting angle, small dropping angle. Swing trail arm through its entire range. Fore and aft crosshair should not move.

5. Check tilt of optics. Set maximum right drift, small sighting angle, small dropping angle. Swing trail arm through its entire range. Fore and aft crosshair should move to right.

Repeat operation with maximum left drift. Fore and aft crosshair should move to left.

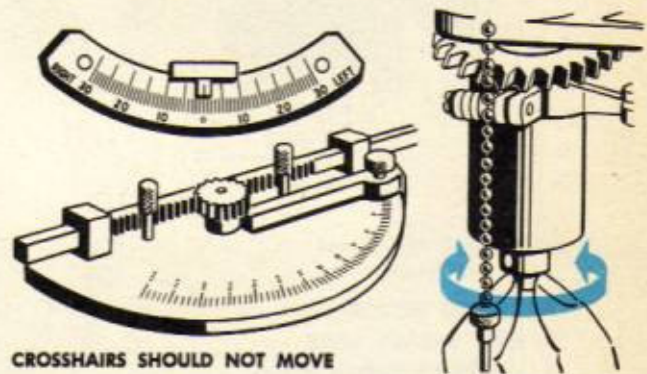

CROSSHAIRS SHOULD NOT MOVE

CHECK FOR PRE-SET TRAIL IN CROSSTRAIL MECHANISM

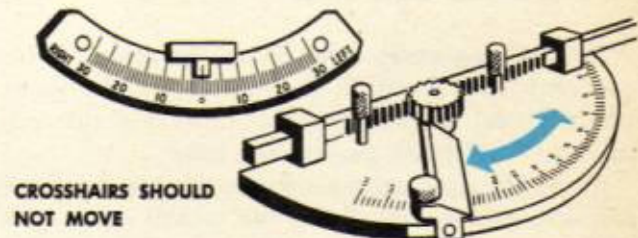

CROSSHAIRS SHOULD NOT MOVE

CHECK FOR DOVETAIL MISALIGNMENT

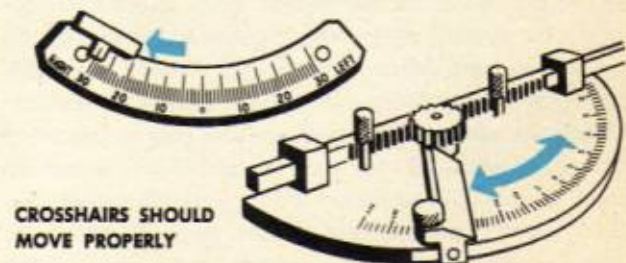

CROSSHAIRS SHOULD MOVE PROPERLY

CHECK TILT OF OPTICS

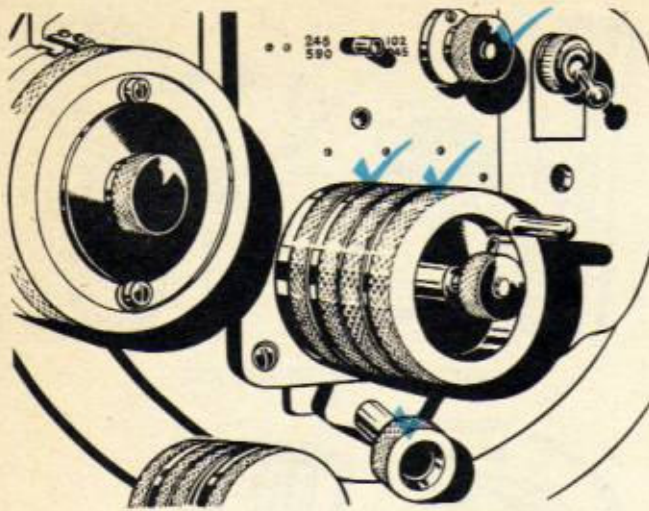

CHECK KNOBS ON RATE END

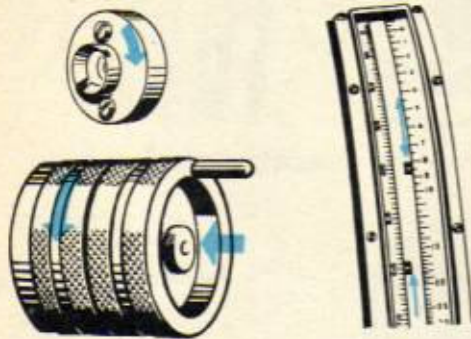

CHECK RATE MOTOR AND DRIVE OF OPTICS

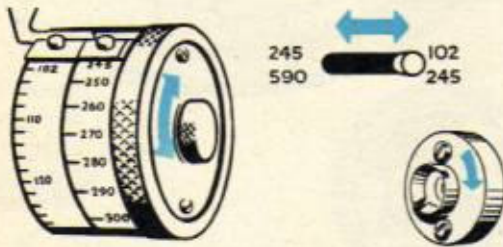

CHECK DISC SPEED DRUM AND GEAR SHIFT

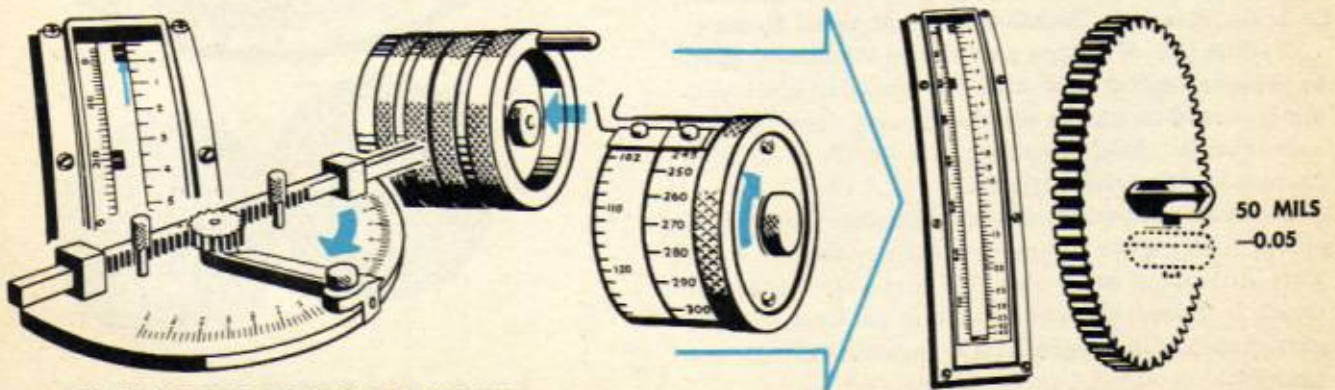

CHECK FOR PRE-SET TRAIL IN RATE END

Rate End

6. Turn BS switch ON. This switch completes circuit to vertical gyro, bubble light, crosshair rheostat, and rate motor switch.

7. Check knobs on rate end. Check action of rate, displacement, and search knobs for any binding in gears or shafts. Check extended vision knob for additional vision and make sure it can be locked in its normal position.

8. Check rate motor and drive of optics. Turn rate motor switch ON. Tachometer adapter should rotate. Engage mirror drive clutch. Optics should drive smoothly. Sighting angle index should move faster as you position dropping angle index at larger dropping angles.

9. Check disc speed drum and gear shift. Shift disc speed gear shift to test proper action of clutch. Turn disc speed drum through its entire range to test for proper action of springs within it.

10. Check for pre-set trail in rate end. Set dropping angle index at -0.05 , trail arm at 50 mils, maximum disc speed, small sighting angle. Engage mirror drive clutch and turn rate motor switch ON. Sighting angle index should not move.

When you set dropping angle index at -0.05 you position roller 50 mils below center of disc. Moving trail arm to 50 mils should bring roller back up to center of disc. In that position sighting angle index does not drive.

If you have to move trail arm less than 50 mils to stop movement of sighting angle index, positive pre-set trail is present. Negative pre-set trail exists if you have to move trail arm more than 50 mils to stop movement of sighting angle index. Amount of pre-set trail is difference between 50 mils and trail needed to stop movement of sighting angle index.

Move dropping angle index to medium setting as soon as you have completed check. This is to prevent excessive wear of disc and roller.

11. **Check for roller slippage.** Set 0 trail. From bombing tables, find probable ATF and DS for mission. Set disc speed into bombsight and check it by 3 successive tachometer readings. Readings should not vary more than $\frac{1}{2}$ rpm. In using tachometer hold it firmly against adapter but do not press too hard. Do not press button while pointer is turning. Always leave last reading on dial when through.

With stop watch, time travel of sighting angle index from coincidence with dropping angle index until it reaches 0° . Repeat this operation with dropping angle index at 3 different settings. For each setting, time of travel should equal ATF for disc speed used. Turn rate motor switch OFF when you have completed check.

12. **Check mirror drive cable length.** Set sighting angle index at 0° , with no extended vision. Look through eyepiece to see that coincidence pointers match. Pointers are forward and left of telescope.

Stabilizer and Course Knobs

13. **Turn SERVO switch ON.** This completes circuit to stabilizer torque unit.

14. **Check course knobs and pilot's PDI.** Engage bombsight clutch, turn PDI switch ON.

With turn knob, turn sighthead through its limits. You can tell by feel of knob whether or not turn worm and stabilized gear sector mesh properly.

With drift knob, move PDI brush through its range. Check for smooth action. After PDI brush reaches either limit, drift gear clutch should slip smoothly when you continue to turn drift knob. To check for loose drift gear clutch and for excessive play between drift worm and drift gear, hold autopilot clutch and test action of drift knob.

Have pilot check his PDI as you move your PDI brush to center, left, and right. His PDI needle should indicate right, when your PDI brush is to left, and vice versa.

15. **Check torque unit and bombsight clutch.** Engage bombsight clutch. Apply torque to sighthead in both directions. Sighthead should resist turning.

Malfunction of torque unit allows directional gyro to precess against case and lose stability after you apply steady torque to sighthead for a short time.

Bombsight clutch slips if clutch is too loose or if there is oil on clutch surfaces.

16. **Check autopilot clutch.** Disengage bombsight clutch and engage autopilot clutch with PDI at 0. Turn drift knob and watch PDI brush. It should not move. If it does, autopilot clutch is too loose or drift gear clutch is too tight. Leave autopilot clutch engaged and bombsight clutch disengaged.

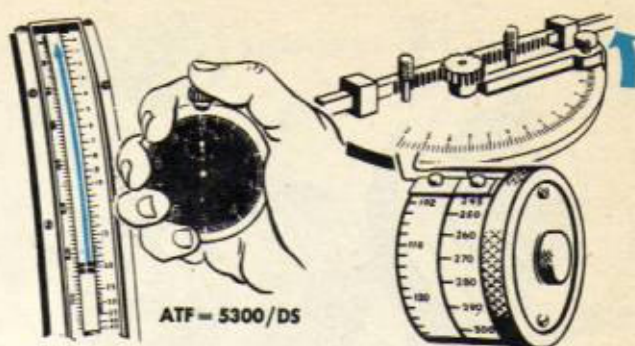

CHECK FOR ROLLER SLIPPAGE

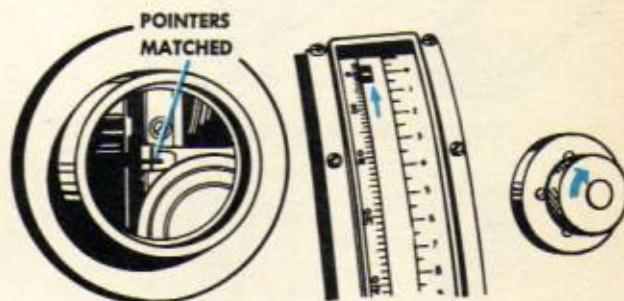

CHECK FOR MIRROR DRIVE CABLE LENGTH

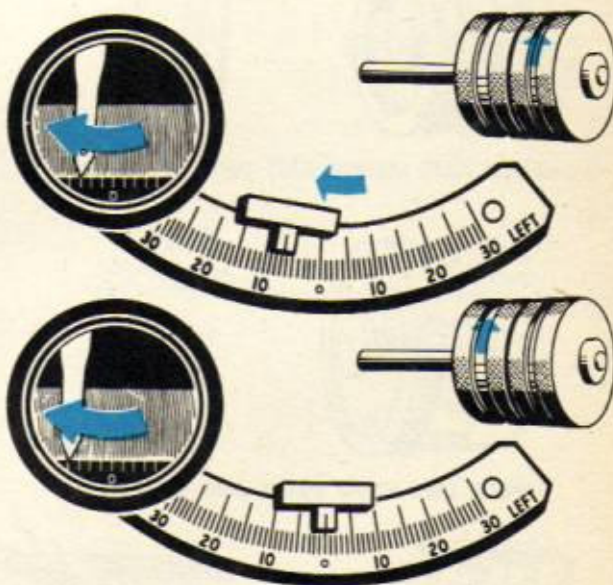

CHECK COURSE KNOBS AND PILOT'S PDI.

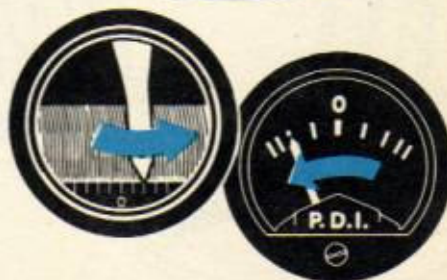

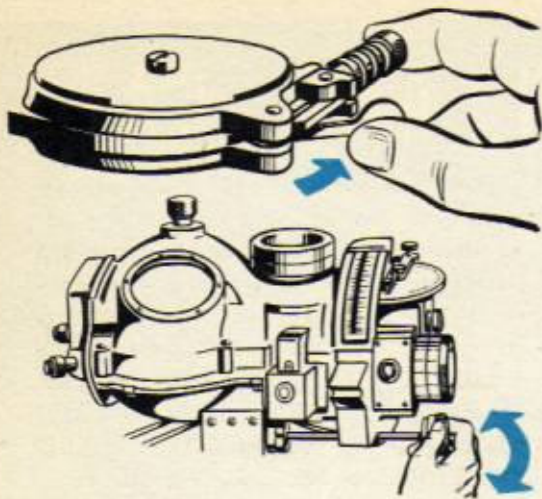

CHECK TORQUE UNIT AND BOMBSIGHT CLUTCH



CHECK AUTOPILOT CLUTCH



PDI BRUSH SHOULD NOT MOVE

Vertical Gyro and Lighting

17. Check vertical gyro and leveling knobs. Uncage gyro. It should hold its position. Use one leveling knob at a time to precess gyro. Bubbles should move in same direction you apply torque. Check to see that leveling knobs return to their normal position when released. Cage gyro.

18. Check bubble light and crosshair light. With BS switch ON bubbles should be lighted.

Turn crosshair rheostat knob full right. Cover lower bombsight window with bombsight cover and look into telescope. Crosshairs should be lighted. These checks are necessary for night missions only. On day missions and when sight is not in use turn rheostat knob full left.

CHECK VERTICAL GYRO AND LEVELING KNOBS

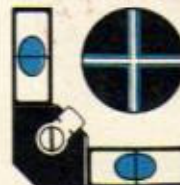
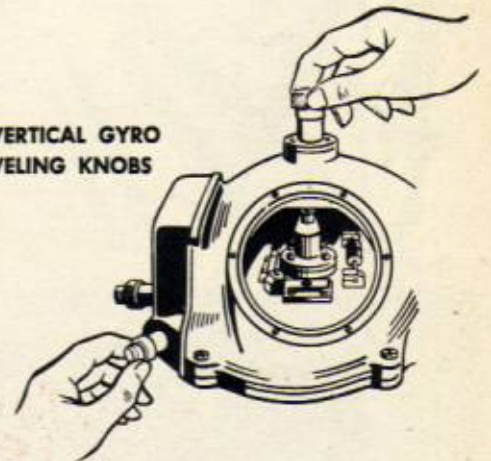

CHECK BUBBLE LIGHT AND CROSSHAIR LIGHT

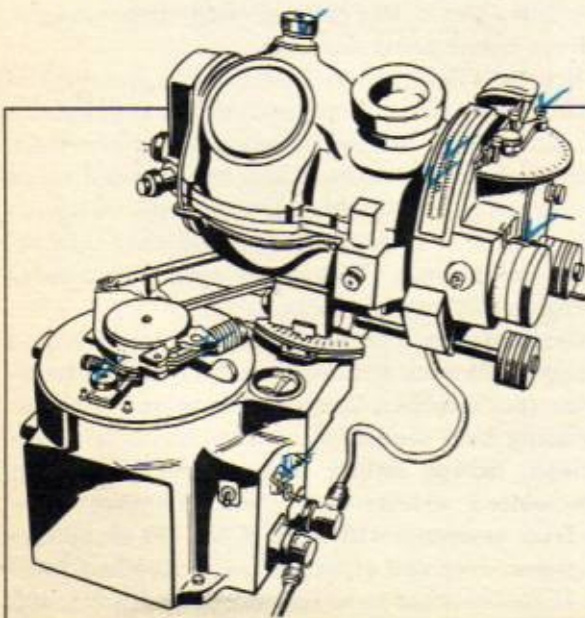

POST-FLIGHT PROCEDURE

Before you cover bombsight:

1. Cage gyro.
2. Set trail arm at 0.
3. Set dropping angle index at medium setting.
4. Set sighting angle index at 70°.
5. Set disc speed drum at lowest rpm.
6. Turn crosshair rheostat knob full left.
7. Engage all clutches.
8. Turn all switches OFF.

FIELD INSPECTION AND CARE



The more you know about your equipment the better you can do your job. Knowledge of inspections and trouble shooting helps you locate and report any malfunction that may be present. This saves maintenance experts time and trouble and allows them to keep your equipment in better condition. You should record accurately the running time of your bombsight so that inspections will be made at the proper time.

Cleaning

1. **Outer case inspection.** Always clean outside of bombsight before opening bombsight case. Check condition of paint. It may be peeling or chipping. Use fast drying, crackle finish lacquer on exterior. You may detect corrosion of magnesium alloy in bombsight as white powder or paste. Remove it completely by scraping it away from base metal. Polish spot with crocus cloth or hardwood stick and retouch with paint or rub in small amount of bombsight oil.

2. **Inner case inspection.** Remove all foreign matter from inside case. Remove dirt with cotton moistened by carbon tetrachloride. **Never stir up dust and dirt inside case.** Remove any corrosion and rust with acid-free kerosene and crocus cloth. Clean surface thoroughly with carbon tetrachloride and clean white cloth. **Never use colored cloth on bombsight.** Dye from it may cause damage.

3. **Brushes.** Before removing brushes, mark head of brush plug and measure amount it extends from brush tube. Mark brushes so you can replace them in same position as before. Clean brushes and tubes with carbon tetrachloride. Do not use benzine. Check sides of brushes for shiny spots; they indicate brushes are sticking. To correct this, polish sides with crocus cloth and re-clean.

4. **Commutators.** Place clean white cloth over end of orangewood stick and moisten with carbon tetrachloride (not alcohol). Clean commutators with this. Keep using new section of cloth until cloth comes out clean. Scrape lightly between segments with wedge-pointed orangewood stick. Remove wire edges from segments with strip of No. 400 aluminum oxide paper over end of wedge point. Re-clean with cloth. If commutator is rough, smooth with No. 400



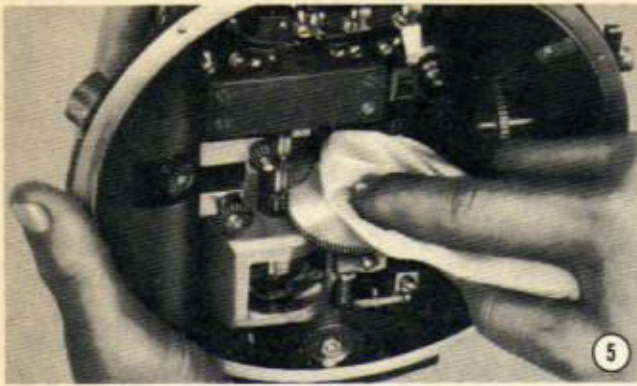

aluminum oxide paper. You must cut guide stick to fit commutator, but never use metal instrument for this purpose. Take care to avoid tapering or hollowing commutator. Brush must have at least 85% contact with commutator.

5. **Disc and roller.** Clean off any dirt, dust, or excess oil with carbon tetrachloride. After cleaning, rub in some light bombsight oil and wipe off excess with clean cloth. Spring tension on disc should be 2 lbs. **Never use abrasives on roller and disc.**

6. **Mirror.** Clean mirror and window with soft tissue paper. **Do not use rough cloth or paper.** This glass is easily scratched.

7. **Clutches.** Remove clutches. Clean drums and collars with carbon tetrachloride. Rub oil into surfaces and wipe off excess oil with dry clean cloth.

8. **Gears.** Clean gears with orangewood stick and carbon tetrachloride. Remove any burrs with Arkansas stone.

9. **Disc speed drum.** Remove cover. Clean springs with carbon tetrachloride, if necessary. After cleaning, rub small amount of light bombsight oil on springs to prevent rusting. Check to see that springs are secure around shaft.

10. **Breaker points.** Clean by pulling cigarette paper through closed points several times. Check to see that points have at least 30% contact. If contact surfaces are pitted or rough, re-surface with fine platinum point file. Polish contact surfaces with No. 400 aluminum oxide paper. Clean with dry white cloth. **Do not use carbon tetrachloride or crocus cloth.**

11. **Slip rings.** Check for rough spots and for faulty insulation between slip rings. Remove rough spots with No. 400 aluminum oxide paper. Clean rings with dry white cloth. Clean slip ring brush surfaces by inserting crocus cloth between slip ring and brush and pulling it through several times. Remove dirt with carbon tetrachloride.

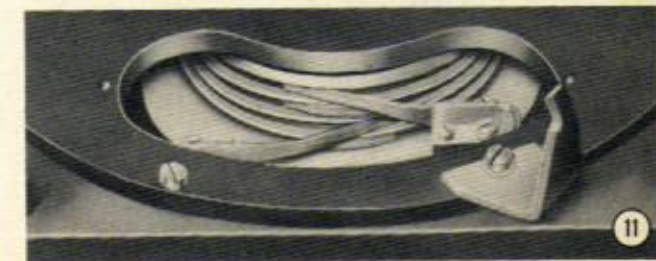
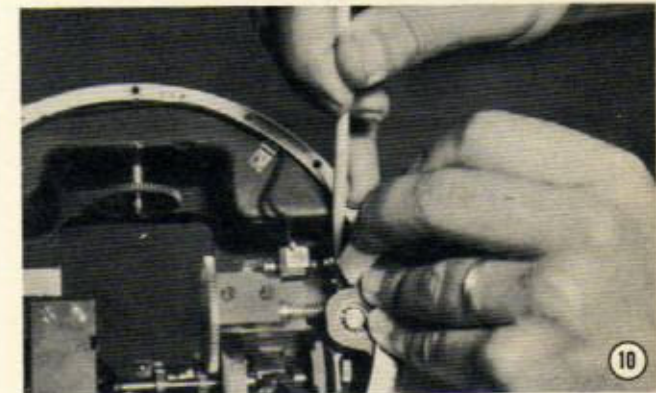
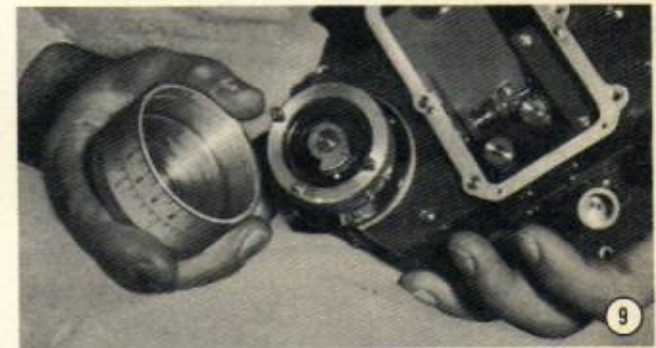
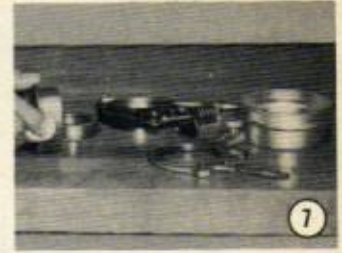

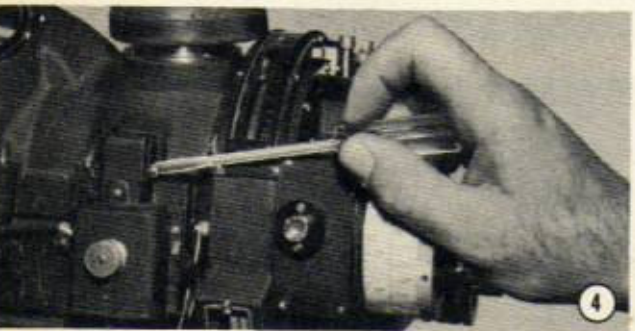
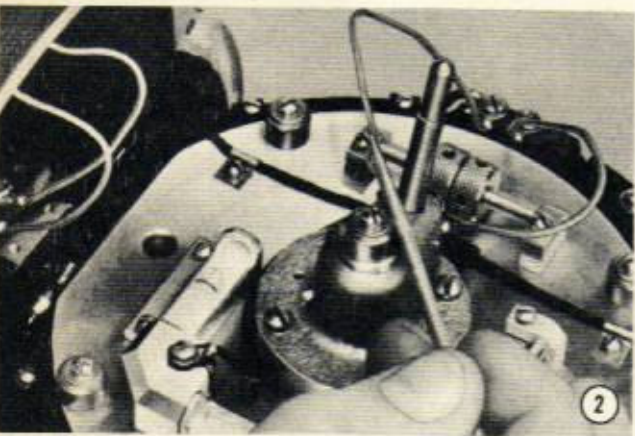
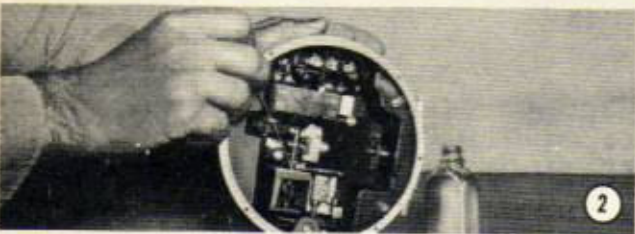
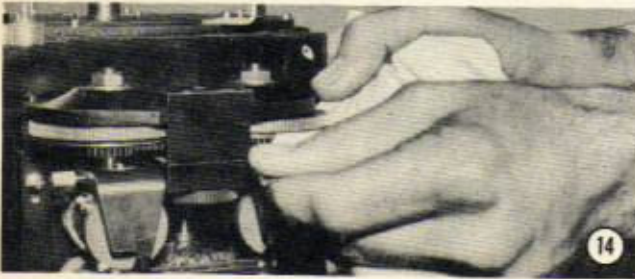
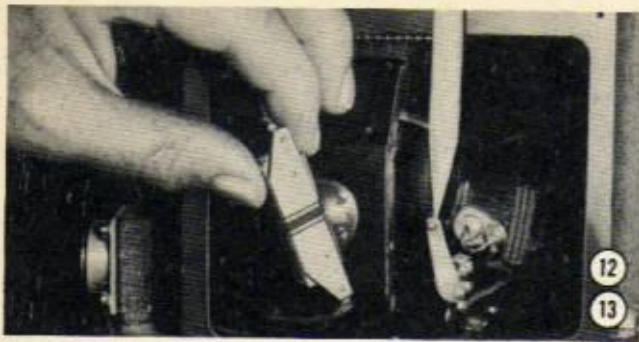

12. **Contact sector.** Inspect sector for arcing. Remove pits and burns with aluminum oxide paper. Lay paper on flat surface and rub sector across paper in alignment with brush movement. Wash sector with carbon tetrachloride and replace.

13. **Contact brush.** Clean brush surface with dry white cloth. There should be $\frac{1}{32}$ inch bevel on top and bottom of point. Obtain 100% contact between flat surface of point and sector. Brush should ride half way up on upper sector when gyro is cold.

14. **Torque clutches.** Clean torque clutches with clean white cloth. Place cloth between clutch disc and cork, wedge gyro, and turn torque motor switch ON. Be careful to hold cloth out of gear teeth and to keep clutch surfaces free of lint. Keep using new section of cloth until no oil or dirt appears on it. **Keep cork facings free of oil.** Oil causes clutch slippage.

Oiling

Never wait until a bearing becomes dry before oiling. Do not touch applicator to anything. After you've oiled the bearings run unit for at least 10 minutes. Then wipe off excess oil.

1. **High speed bearings.** Oil gyro rotor bearings, torque motor armature bearings, and rate motor shaft bearings with one drop of heavy bombsight oil when necessary. In most cases these bearings must be oiled every 15 to 25 hours.

2. **Low speed bearings.** Oil low speed bearings such as governor bearings, disc speed drum shaft bearing, and gudgeon bearings, with one drop of light bombsight oil when necessary.

3. **Disc, roller, clutch drums and collars, disc speed drum springs.** After cleaning, rub in light bombsight oil and wipe off excess oil with clean cloth.

Electrical Inspections

1. **Wiring.** Check for frayed or burned insulation, faulty terminals, and improper shaping. Check terminal screws for tightness, stripped threads, and bad screw driver slots. Make proper repairs and replacements. When necessary, check wiring throughout with continuity tester.

2. **Flexible leads.** Make sure that flexible leads on gyro do not touch case or each other regardless of gyro position. When flexible leads are re-shaped precession runs must be made. Shape them like question marks with orangewood stick. **Never use sharp-edged instrument for shaping leads.**

3. **Bubble light.** Check and replace if necessary.

4. **Crosshair light.** If bulb is lighted and crosshairs are not visible, move mirror adjusting arm until beam is on crosshairs.

Adjustment Inspections

1. **Automatic release mechanism and indices.** Automatic release points should close when sighting angle index and dropping angle index are perfectly matched.

2. **Extended vision.** Check to see that extended vision knob works smoothly and that spring pushes knob out. If it sticks, remove and clean with carbon tetrachloride.

3. **Mirror drive cable.** Test mirror drive cable for proper spring tension. Tension should be 8 ounces when sighting angle index is at 30°. Adjust tension by turning spring to new notch inside spring housing. You can make fine adjustments by turning spring housing 180°, then moving spring to new notch. Inspect cable for fraying.

4. **Course knobs.** Remove burrs from all gears. To adjust end play of turn knob shaft, first turn locking nuts all the way down. Then back off ½ turn and lock. You can check this play on end of shaft or between course knobs. Adjust backlash between turn worm and stabilized gear sector with shims. Always place more shims between turn worm housing and sight than are necessary to obtain clearance. Then remove .001 inch at a time to obtain minimum clearance without binding. Place same number of shims between drift knob shaft bracket and sight case as there are between turn worm housing and sight case. This prevents warping and binding of drift knob shaft. Turn knob through range of stabilized gear sector. Loosen set screw in drift worm housing and rotate housing until there is no binding or excess play. Tighten set screw. Drag should be equal on both knobs. To adjust clearance between knobs, loosen lock nut on drift knob shaft and turn drift knob until you get desired clearance. Then tighten lock nut.

5. Dovetail alignment.

Settings: Small sighting angle, small dropping angle.

Inspection: Swing trail arm through entire range. Fore and aft crosshair should not move. If it does move, dovetail is out of alignment with longitudinal axis of stabilizer.

Correction: Loosen 4 screws of dovetail locking bracket and turn bracket until motion of fore and aft crosshair stops when trail arm is moved. This adjustment is exceedingly fine; when you tighten screws do it slowly to make sure bracket does not move. Re-check after screws are tight.

6. Pre-set trail in crosstrail mechanism.

Settings: 0 drift, 0 trail, small sighting angle.

Inspection: Remove dovetail locking pins. Rotate

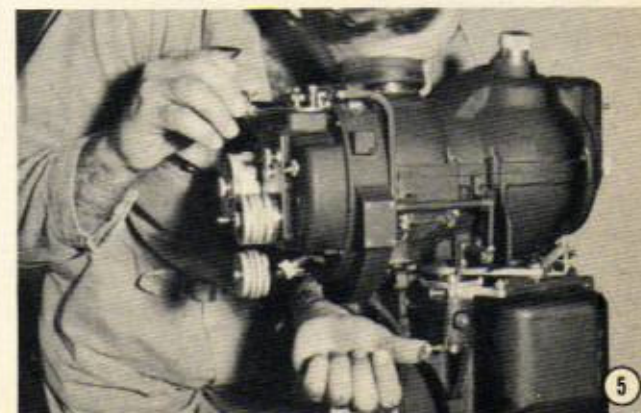
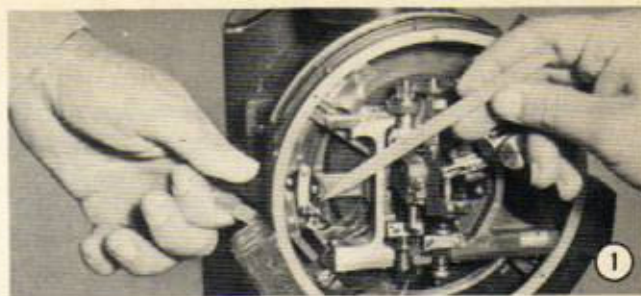

bottom of dovetail shaft. Fore and aft crosshair should not move. If it does move, there is pre-set trail in crosstrail mechanism.

Correction: Check to see that scribe mark on trail rack is opposite scribe mark on trail arm pinion when trail arm is at 0. If it is not, remove trail arm pinion and align scribe marks. If further adjustment is necessary change shims between sight case and trail bell crank.

7. Roller zeroed.

Settings: 0 trail, 0° dropping angle, maximum disc speed.

Inspection: Remove rate end inspection plate. If roller is moving, there is pre-set trail in sight.

Correction: Loosen trail arm clamp screw and turn trail setting gear until roller is below center of disc. Then center roller by turning trail setting gear until roller stops rotating. Tighten clamp screw and re-check. Displacing roller below center and bringing it back to center eliminates any backlash error. Don't keep roller at center of disc, except for test purposes; otherwise, it causes flat spot on roller and depression in center of disc.

8. Telescope vertical.

Settings: 0° sighting angle, bubbles level, gyro locked in position with wooden wedges or clamps.

Inspection: Place precision mirror directly beneath telescope and level it, or use bowl of mercury. Look through telescope into mirror. You should see 2 images or circles. Crosshairs should split or bisect the rear image.

Correction: If lateral crosshair is off, correct by turning eccentric screw on first sheave. Before you make this correction, again check sighting angle index and bubbles for correct positions. If fore and aft crosshair is off, correct by loosening turret head screw on crosstrail bell crank and gently tapping top of telescope in desired direction until fore and aft crosshair is centered. Then carefully tighten turret head screw in order not to disturb setting.

9. Roller slippage.

Settings: Disc speed, 265 rpm; 0 trail, tangent dropping angle, 1.5; mirror drive clutch engaged.

Inspection: With stop watch, time travel of sighting angle index from time indices meet until it reaches 0°. Time should be 20 seconds. Repeat this operation with dropping angle index at several different settings through range of tangent scale. If readings do not coincide, there is roller slippage.

Correction: Clean disc and roller. Check disc spring pressure and look for excessive friction in gear train.

10. **Torque unit bayonet springs.** Check adjustment of springs to make certain cork facing on

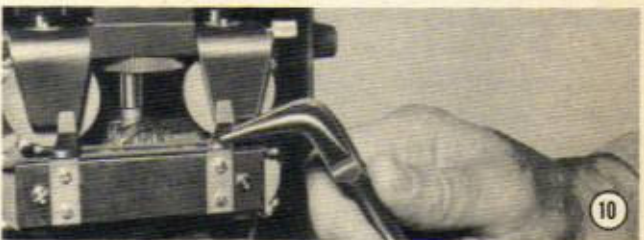
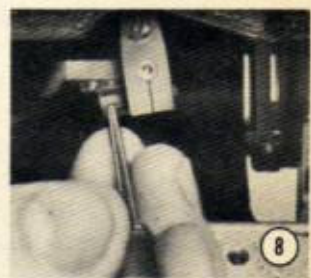
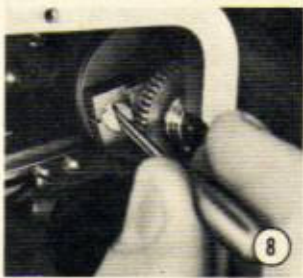
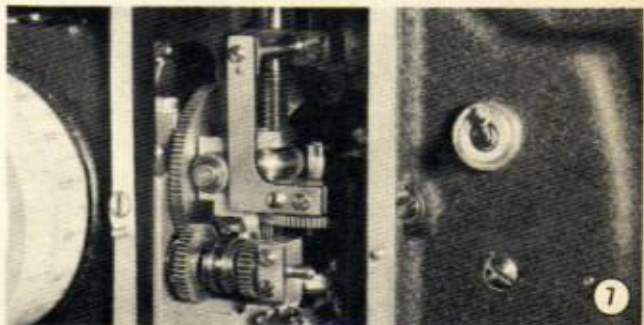
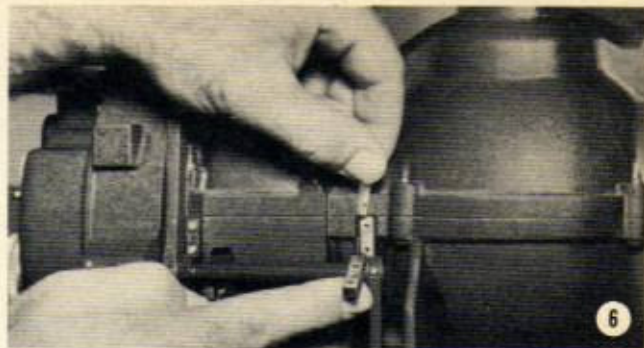

clutch plate is not contacting surface of clutch drive gear when clapper magnet is not energized.

11. **Torque unit clapper magnets.** Try to precess gyro manually while both stabilizer and torque mo-

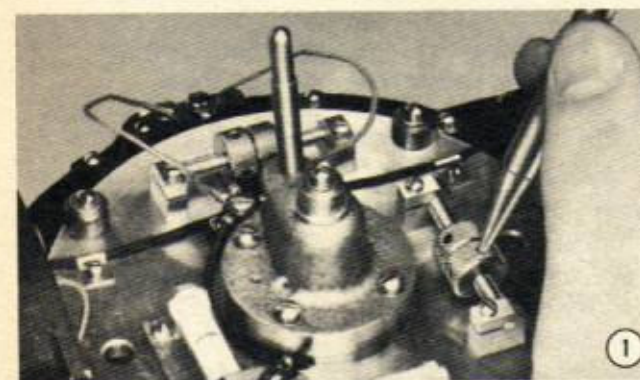
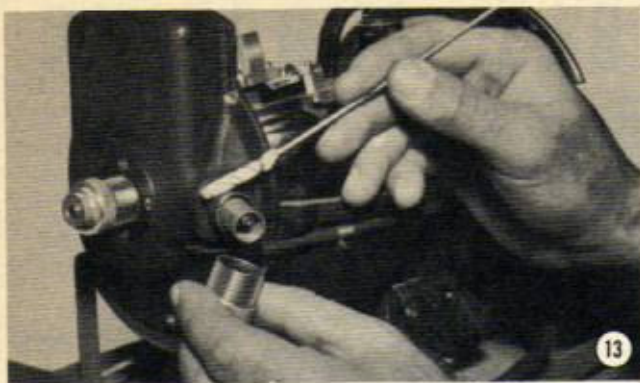

tor switches are ON. Check operation of clappers. Make sure counter-force applied by torque unit is steady and in right direction. Check clapper pins for freedom and security.

12. **Caging knob.** Check for rust, dirt, and binding. Disassemble, clean, and lubricate with light bomb-sight oil if necessary.

13. **Leveling knobs.** With gyro running, check for precession in proper direction as you use knobs. Bubbles should move in same direction top of knob is turned. Check for binding of shafts due to dirt or corrosion. Disassemble, clean, and oil if necessary.

14. **Clutch tensions.** Using spring scale, check and adjust tensions of clutches. Make adjustments with stabilizer and torque motor ON. Proper tensions and adjustments are:

Bombsight clutch (18-22 lbs). Attach spring scale to end of bombsight connecting rod and pull at 90° to clutch radius. Adjust tension by turning spring screw on clutch collar.

Autopilot clutch (10-14 lbs). Attach spring scale to autopilot connecting rod and pull at 90° to clutch radius. Adjust spring tension by turning turret head screw on clutch collar.

Drift gear clutch (6-8 lbs). Attach spring scale to stud on drift gear clutch arm and pull at 90° to clutch radius. Adjust tension by turning spring screw on collar below drift gear.

Precession Runs

1. **Vertical gyro.** Check flexible leads and let gyro run for at least 50 minutes to attain running temperature. Set 0 drift, 0° sighting angle. Place sight on north heading. Look through telescope and use leveling knobs to precess crosshairs to center of grid. After 2 minutes observe position of fore and aft crosshair and note amount and direction of precession. Repeat operation on opposite heading. Easterly precession should be equal on both headings and should not exceed 9 mils.

If precession is unequal you must move fore and aft precession weights mounted on top right hand side of gyro housing. To counteract precession to right, move weights forward. To counteract precession to left, move weights to rear.

Next, check for precession on east and west headings, and observe lateral crosshair. Use lateral weights to correct for unequal precession on these headings. If hair moves forward move weights to left and vice versa.

2. **Direction gyro.** Run stabilizer at least 15 minutes. Turn torque motor switch ON. Set PDI at exactly 0 and engage autopilot clutch. Directional gyro should not precess in 15 minutes. If it precesses clockwise, add weight to brush end of gyro housing or remove weight from other end. If precession is counter-clockwise reverse procedure.

TROUBLE SHOOTING

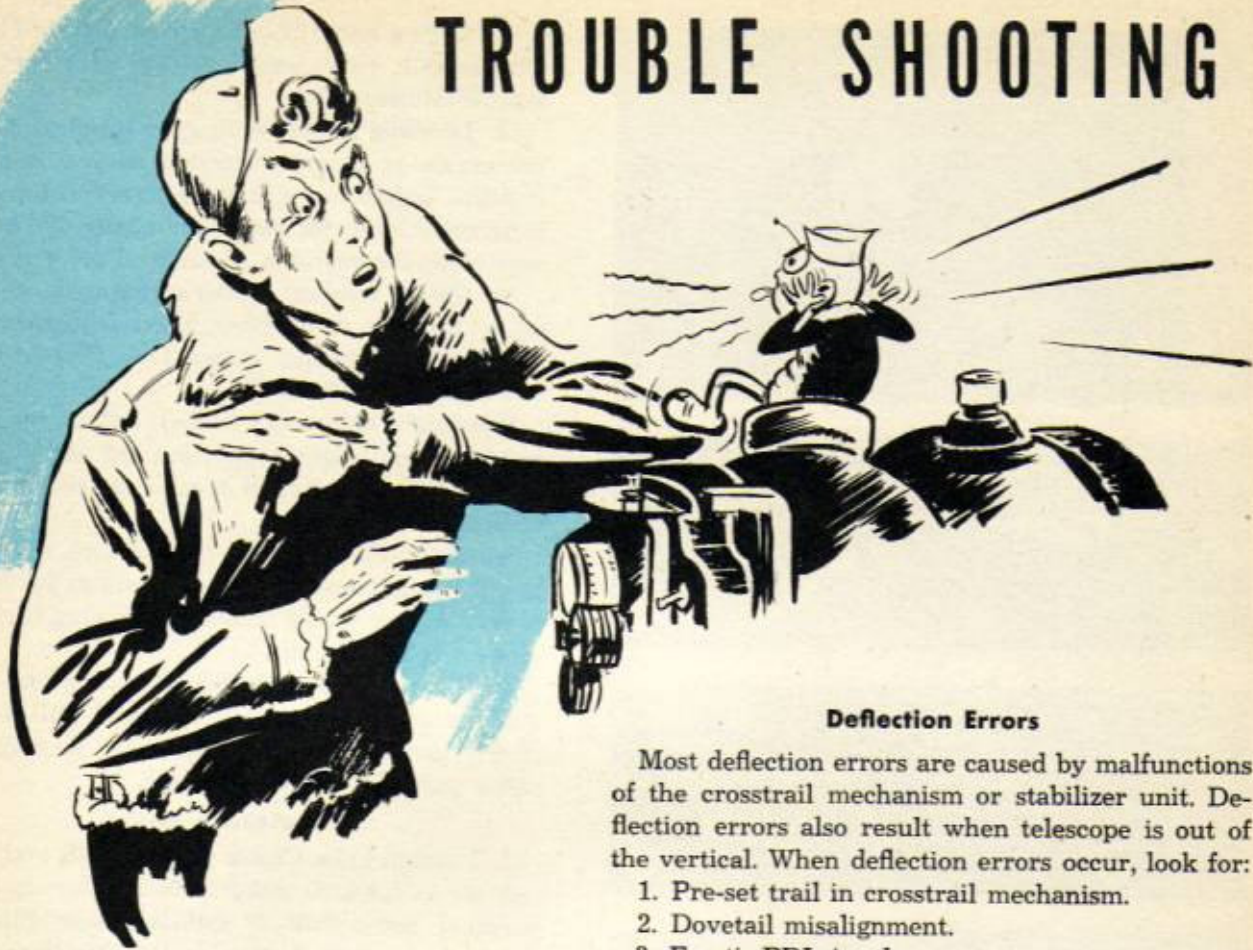

When bombing errors or apparent malfunctions occur, make following checks before submitting a malfunction report:

1. Make complete preflight inspection of all bombing equipment.
2. Check accuracy of bombing altitude and true airspeed computations.
3. Check correctness of bombing tables and target information.
4. Check correctness of data set in sight. Use tachometer properly.
5. Check all switches and controls for proper position.
6. Check extended vision knob for proper position.
7. Check leveling knobs for sticking.
8. Turn switches off and on several times when some unit fails to operate.
9. Check disc speed gear shift for proper position.
10. Check electrical fuses.
11. Check generators to see if switches are ON and if voltage output is sufficient.

Deflection Errors

Most deflection errors are caused by malfunctions of the crosstrail mechanism or stabilizer unit. Deflection errors also result when telescope is out of the vertical. When deflection errors occur, look for:

1. Pre-set trail in crosstrail mechanism.
2. Dovetail misalignment.
3. Erratic PDI signals.
4. Lateral leveling knob sticking.
5. Bombsight clutch slipping.
6. Drift gear clutch slipping.
7. Directional gyro failure.
8. Torque unit failure.
9. Course knobs sticking.
10. Telescope out of vertical.
11. Vertical gyro precessing or not running.
12. Autopilot clutch engaged or sticking.

Range Errors

Malfunctions in the rate end cause most range errors. When range errors occur, look for:

1. Pre-set trail in rate end.
2. Improper length of mirror drive cable.
3. Roller slipping.
4. Erratic disc speed.
5. Fore and aft leveling knob sticking.
6. Vertical gyro precessing or not running.
7. Automatic release mechanism failure.
8. Mirror drive clutch not engaged properly.
9. Rate knob binding.
10. Displacement knob binding or slipping.

COLD AND HOT WEATHER OPERATION

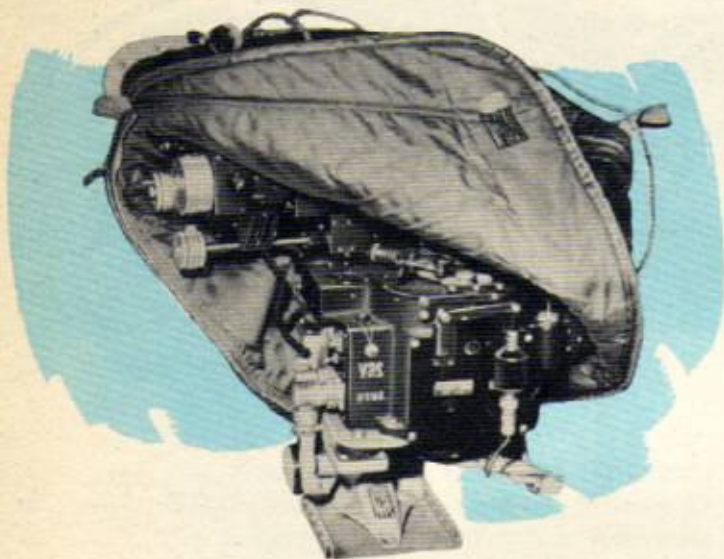

A-1 BOMBSIGHT COVER
(Electrically Heated)

Low Temperature Operation

Your bombsight does not operate efficiently if its temperature is below -20°C . Even above that limit you should always keep the bombsight warmer than the surrounding air so that moisture will not condense inside. Condensed moisture fogs the optics and may damage the working parts of the bombsight.

When the ground temperature is below -20°C , you should keep both sighthead and stabilizer in a warm, dry room between missions. If the bombsight is to be stored for any length of time put it in an individual box. Place $\frac{1}{2}$ lb. of silica gel in the box to keep the air dry.

Before taking your bombsight to the airplane in preparation for a mission at low temperatures, cover it with a heavy blanket and allow it to run for 2 hours. This should thoroughly warm all the parts. Install the bombsight in your airplane as short a time as possible before takeoff. Cover it again with the blanket and turn it on as soon as the engines are started. Leave it running, and keep it covered except when you are using it.

If you should allow the temperature of the bombsight to fall below -20°C while you are not using it, turn the switches on alternately for not more than 5 to 10 seconds each. Continue this until the units have generated enough heat to run smoothly. After the rest of the bombsight is running satisfactorily warm up the rate motor in the same way.

If it is available, always use the A-1 electrically heated bombsight cover at temperatures below freezing. This cover has a thermostatic control so that it keeps the bombsight at a minimum temperature of about -10°C . When you remove the cover you have to unplug the connecting cord. There is a pocket in the cover for your tachometer.

Fogging of Optics

The optics will not fog if you are careful to keep the bombsight warmer than the surrounding air. If the optics do fog, direct warm air from the nose heating tube against the lower window of the bombsight. Continue until the fogging clears up. If the heating equipment in the airplane is not such that you can do this, remove the lower window for a few minutes. If necessary remove the eyepiece also, to encourage circulation of air. Always replace the window and the eyepiece after a short time so that the bombsight will not lose too much heat.

Operation In Hot Dry Climates

In hot dry climates it is important that you take every precaution to keep sand, dirt, and excess oil out of your bombsight.

Use aircraft instrument sealing compound to seal around the index window and the windows over the vertical gyro and the PDI.

On every mission apply adhesive tape around the lower sighthead window before the airplane lands. Cover ventilating holes with adhesive tape before each landing. Always remove this tape after takeoff on the next mission.

Oiling of gyro rotor bearings and cleaning of commutators is particularly important in hot weather operation. You should see that the rotor bearings are inspected every 15 hours or every 15 days, whichever comes first, and oiled if necessary. If the bombsight is in an airplane parked in the hot sun for 2 hours or more the gyro rotor bearings should be inspected to see if oiling is needed.

REFERENCE: Technical Order 11-80-25

BOMBING WITH DEFECTIVE BOMBSIGHT

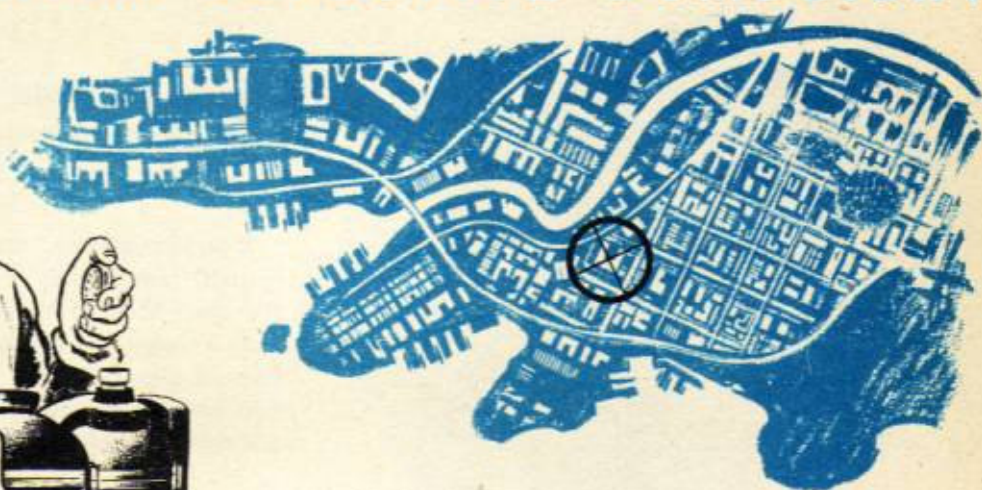

placing the PDI. You can solve the range problem as usual. If you pre-set the dropping angle you have more time to direct the pilot for course.

Failure of Vertical Gyro

If your vertical gyro loses its stability you must make your bombing run with the gyro caged. Before you go on course, ask the pilot for a level and adjust the stabilizer so that the fore and aft bubble is level. At the same time notice the position of the lateral bubble. If the lateral bubble is off center, offset the aiming point in the same direction. In this way you can compensate for the error caused by the incorrect vertical reference that the gyro gives you. **Remember: $\frac{1}{2}$ bubble length equals about 18 mils.**

Tachometer Inoperative; Setting up ATF with Stop Watch

If your tachometer does not work you can set up the DS with a stop watch. To set a DS in the sight with a stop watch, you must first be sure the trail arm is at 0. Determine the ATF to be used for your BA and TAS. You can find the ATF for your bomb from the bombing tables. Set the disc speed drum at the approximate DS. With the stop watch, time the travel of the sighting angle index from the instant it is opposite the dropping angle index until it is opposite 0° sighting angle. This time should be the same as the ATF of the bomb.

If the stop watch reading is too great, increase the rpm to get the desired ATF. If the stop watch reading is too small, decrease the rpm. Check again and readjust the disc speed drum until the ATF reading is correct.

Even though you have given your bombsight a thorough preflight, parts of it may become inoperative on a tactical bombing mission. In such an emergency you can usually complete the mission and drop your bombs with reasonable accuracy by making the necessary changes in procedure.

Rate Motor Inoperative

First, use the bombsight as a driftmeter to solve for the wind direction and speed. Then find the groundspeed for the heading on which you will make your bombing run. Now, from your bombing tables find the dropping angle for this heading and pre-set it into the bombsight. As the lateral crosshair approaches the target, turn the displacement knob to keep the crosshair on the target. In this way you do manually what the rate motor does mechanically. Otherwise the bombing procedure is the same as usual. If you have an accurate drift solution and solve for the correct dropping angle your error will be small.

Failure of Directional Gyro or Torque Unit

Use the bombsight as a driftmeter to solve for drift. Pre-set the drift angle on the bombsight and direct the airplane over the target. You can do this by directing your pilot on the interphone or by moving the autopilot clutch with your hand, thus dis-

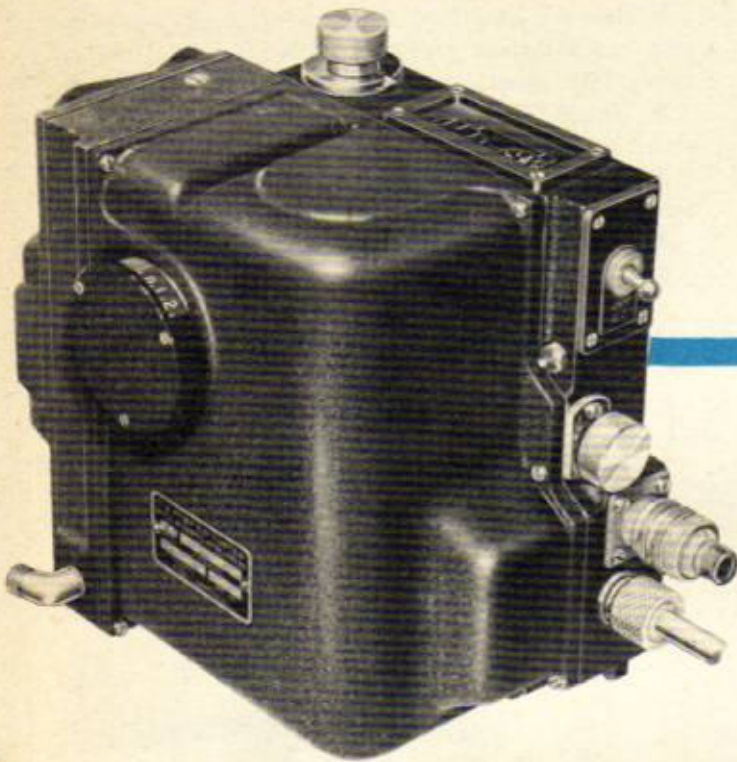

GLIDE BOMBING ATTACHMENT

The glide bombing attachment is an auxiliary instrument for use with the M-series bombsight. With it you can use the bombsight accurately in climbs and glides as well as in horizontal flight. The attachment greatly simplifies your problems even in horizontal flight. With it you can make all settings well in advance of the bombing run with small loss in accuracy.

The ATF of a bomb dropped during a climb or glide varies with the bombing altitude and the vertical velocity at the time of release. The GBA measures altitude and vertical velocity by means of a barometric element connected to the pitot-static system. It computes the disc speed required for that bombing altitude and vertical velocity, and drives the bombsight disc at the proper speed.

The vertical velocity is shown on the drum type scale to be seen through the window on the side of the main cover. The scale is graduated in feet per minute. On its right side you can read from 0 to 3000, for climbs; on its left side, from 0 to 9000, for glides. Each division on this scale is 200 ft/min.

You read the altitude scale through the window in the top of the computer case. The main scale indicates intervals of 1000 feet. The vernier reads from

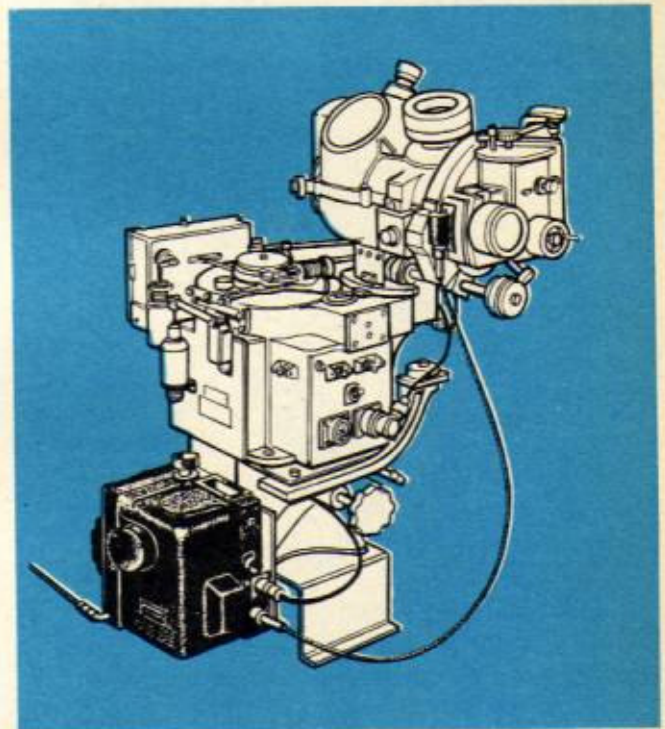

0 to 1000 feet, in intervals of 50 feet. This altitude scale indicates pressure altitude plus any correction you set in.

Use the altitude knob to set bombing altitude into the GBA. The instrument indicates pressure altitude until you make a correction for pressure and temperature variations. To make this correction pull out on altitude knob, turn it, then work it back in.

The GBA computes disc speed on the basis of the time it would take a bomb to fall in a vacuum (VTF). Therefore, you must put in a correction so that the disc speed in the bombsight will be based on ATF. Do this by turning the disc speed correction

knob at the left of the altitude scale. The amount of correction in rpm is indicated on the scale attached to the knob.

Power is supplied to the instrument through a cable connection on its right side, below the altitude knob.

The flexible drive shaft between bombsight and GBA connects with the attachment at the lower right side of the computer case. The other end of the shaft connects with the bombsight disc through a special tachometer shaft bracket that replaces the standard tachometer shaft bracket.

PREFLIGHT PROCEDURE

1. Check to see that all connections are secure.

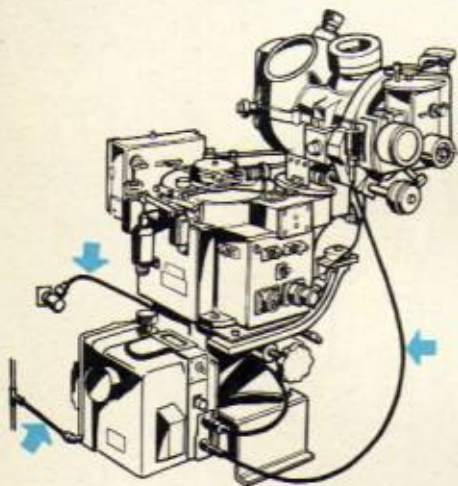

2. Put disc speed gear shift in neutral position, turn rate motor switch OFF, set disc speed drum at low rpm setting, and disengage mirror drive clutch.

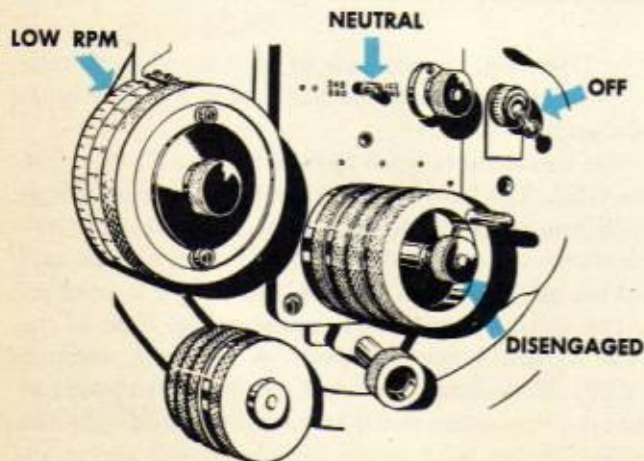

MOUNTING THE GBA

1. Remove standard tachometer shaft assembly and bracket from rate end of bombsight. Replace them with special assembly furnished with GBA.
2. Mount GBA on or near stabilizer so that it has shock mounting.
3. Connect flexible shaft from GBA to special tachometer shaft assembly on bombsight.
4. Connect tube from static line to GBA.
5. Connect power cable to GBA.

3. Turn GBA ON and let it run for at least 10 minutes.

4. Check vertical velocity scale to be sure it does not move from 0 more than 240 ft/min.

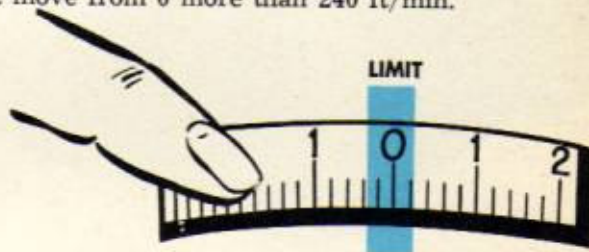

5. Check to see that altitude scale indication remains constant or within 20 feet.

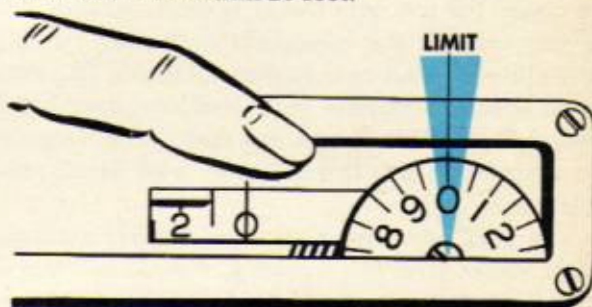

6. Check disc speed. To do this, set disc speed correction knob at 0 and set altitude scale, for instance, at 6000 feet. Disc speed should be: $\frac{21250}{\sqrt{BA}}$ or,

in the case of 6000 feet, 274.3 rpm. Check disc speed with tachometer. Indication should not vary more than 1 rpm from correct value. Check disc speed for 3 different altitude settings. Other convenient settings and disc speeds are: For 12,000 feet—194.0 rpm; for 18,000 ft.—158.4 rpm.

7. Set altitude scale on GBA so that at target elevation it would indicate approximately 0.

8. When preflight is complete, turn GBA OFF.

PROCEDURE AFTER TAKEOFF

1. Be sure disc speed gear shift is in neutral, rate motor switch is OFF, disc speed drum is at low rpm setting, and mirror drive clutch is disengaged.
2. Turn GBA switch ON and allow sufficient time for instrument to indicate correct altitude.
3. Level off at estimated pressure altitude of release, turn GBA OFF and compute your BA. Be sure that airplane is flying level at estimated pressure altitude of release, then set BA into instrument and turn GBA ON. After using altitude knob, be sure to work it back in.
4. From disc speed correction tables, find and set in your proper disc speed correction.
5. From your regular bombing tables, find and set in trail for estimated BA and TAS at which bombs will be released.

PROCEDURE FOR LEVEL BOMBING

If you use your GBA in level flight, use your regular procedure **except**: Put disc speed gear shift in neutral, leave rate motor OFF, set disc speed drum at low rpm, and engage mirror drive clutch when lateral crosshair intersects target.

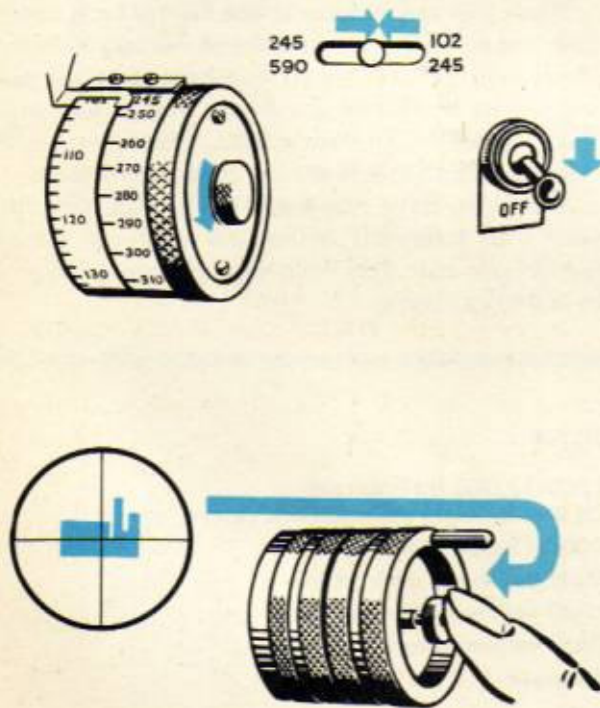

PROCEDURE FOR GLIDE BOMBING

1. Instruct pilot to climb to approach altitude for glide bombing and level off.
2. Uncage gyro and level bubbles while in level flight just prior to glide.

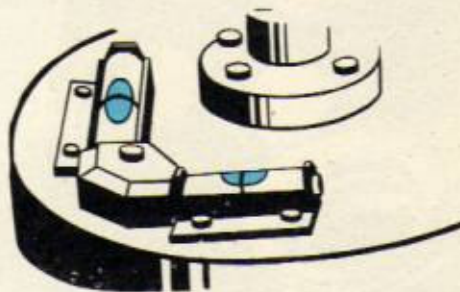

3. After glide is started loosen stabilizer mount and tilt bombsight until telescope is centered under eyepiece.



4. Set up course in usual manner.
5. Hold lateral crosshair on target by double gripping range knobs until bomb release. You have to adjust rate continually because in glide bombing you can have only momentary synchronization.

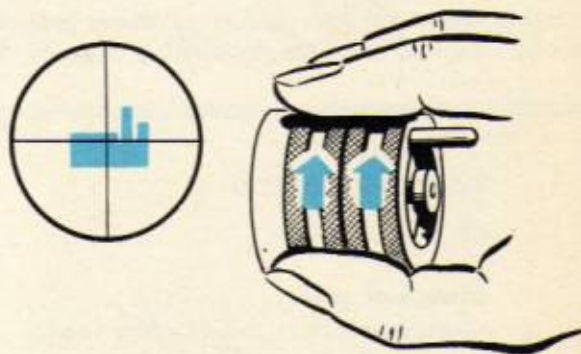

Caution:

Always be sure to check limits of GBA and angles of glide at which bombs may be safely released from your airplane.

MODIFICATIONS AND ATTACHMENTS

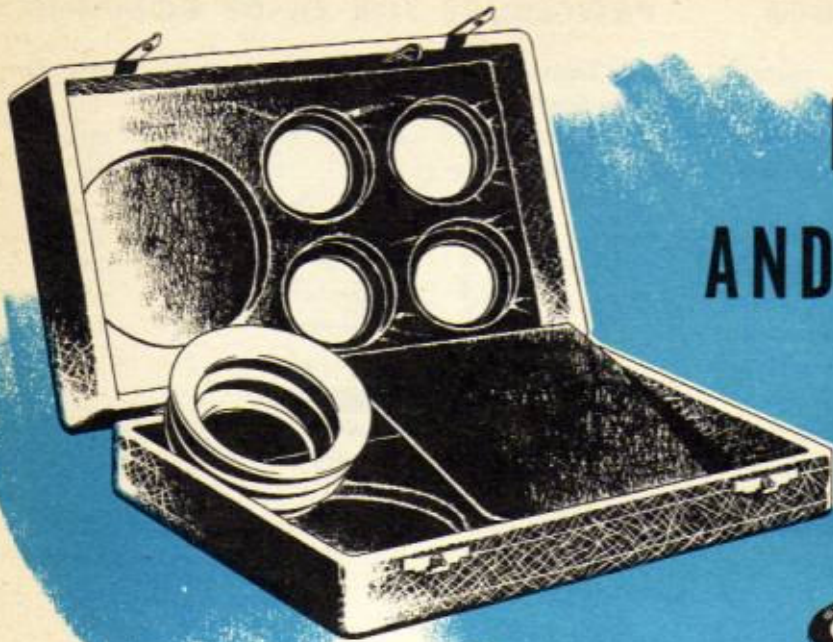

ANTI-GLARE LENSES

You can install a filter in your bombsight to help you when there is glare or when other conditions of poor visibility exist. Filters are issued in kits of 5 with an interchangeable rubber eyepiece.

To install a filter select the one you want to use and put it in the rubber eyepiece. Remove the regular eyepiece and put the filter eyepiece in the eyepiece sleeve of the sight.

The filter kit contains 2 uncolored polaroid filters. One of these cuts out about 60% of the light. The other you can adjust to cut out from 60% to all of the light. When you use either of these polaroid filters you have to twist the entire filter assembly in

its seat until the glare is reduced to a minimum. You control the amount of light the filter transmits by rotating the inner ring of the filter assembly.

When you are not using the filters, keep them in their case. The case should not be left where the filters will get too warm, for heat damages them. Do not let the filters get damp, and do not expose them needlessly to strong light. Clean them with a clean soft cloth and moisture from your breath.

After you have had experience with the filters, your own judgment is the best basis for selecting the proper one. The following table will help you in making a choice:

VISUAL CONDITION	FILTER
Glare from water.....	1000-12,000 ft.: Polaroid 20,000 ft.: Light yellow, dark yellow, or red
Glare from snow.....	1000-12,000 ft.: Polaroid
Glare from sandy soil or white sand.....	Light yellow or dark yellow
Heading into sun.....	Light yellow or dark yellow
Haze, fog, overcast, or shadows.....	Dark yellow or red
Searchlight glare.....	Polaroid

REFERENCE: Technical Order 11-30-35

DISC SPEED AND TRAIL MODIFICATIONS

As ordinarily constructed, the M-series bombsight provides for a maximum trail value of 150 mils and a minimum disc speed of 102 rpm. These limits do not give sufficient range when you are bombing at exceptionally high altitudes and airspeeds.

The M-9 bombsight can be modified to permit trail and disc speed settings needed for bombing at altitudes up to 50,000 feet and airspeeds as high as 500 mph. Sights with trail modification only are designated M-9A. Sights with both disc speed and trail modifications are M-9B.

Disc Speed Modification

The disc speed modification gives you disc speeds of from 77 rpm to 186.5 rpm with the disc speed gear shift in low disc speed position. With the disc speed gear shift in high disc speed position you get

disc speeds of from 186.5 to 450 rpm. These new speeds are obtained by changing the size of the gears on the rate motor shaft and the size of the idling gears in the disc speed change assembly.

Trail Modification

The trail modification permits you to set in trail values up to 230 mils. To obtain this greater range, the arc through which the trail arm swings is increased and the gear ratio between the trail arm and the nut gear is changed. An additional device is installed so that not more than 150 mils of trail can be set in the crosstrail mechanism.

TRAIL SPOTTING DEVICE

The trail spotting device permits you to reduce trail setting in the rate end without introducing an error in crosstrail. You use it in train bombing to get the center bomb, and thus the **mean point of impact**, of the train on the target. You can also use it when you want to reduce trail to compensate for RCCT error.

To put the MPI of a train of bombs on the target, use these steps:

1. Set trail spotting plate at 0 and lock.
2. With trail arm, set in correct amount of trail for your BA, TAS, and type of bomb. Lock trail arm.
3. Calculate how much you need to reduce trail to get center bomb on target, just as you would do if you did not have trail spotting device.

$$\text{Mils to reduce trail} = 500 \times \frac{(\text{No. in Train} - 1) (\text{Bomb Interval in ft.})}{\text{Bombing Altitude}}$$

4. Set and lock trail spotting plate at number of mils by which you want to reduce trail.

For single releases always set and lock trail spotting plate at 0.

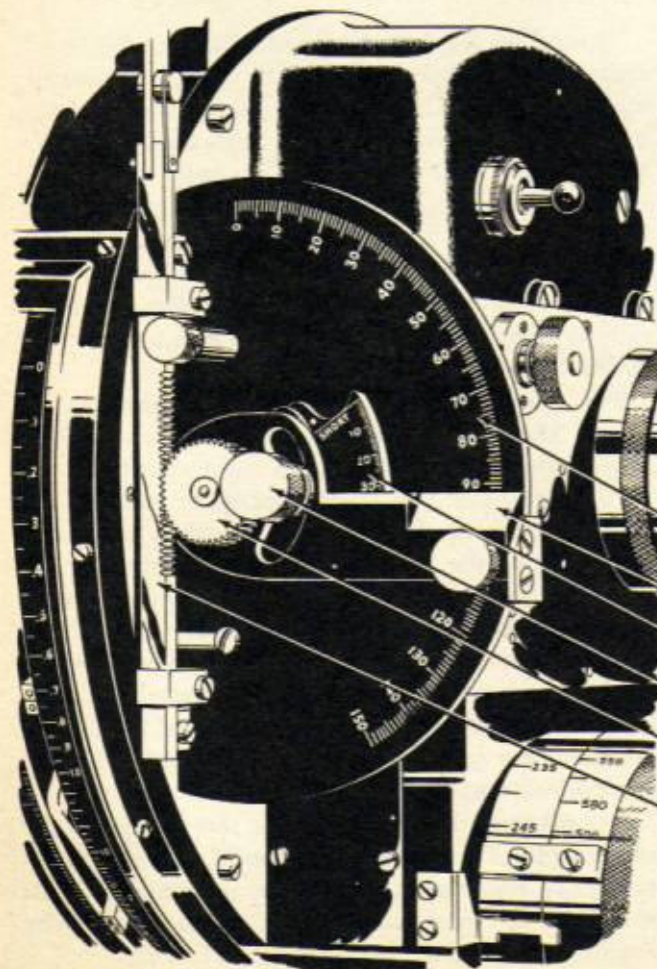

TRAIL SPOTTING DEVICE

1. TRAIL PLATE
2. TRAIL ARM
3. TRAIL SPOTTING PLATE
4. TRAIL SPOTTING KNOB
5. TRAIL ARM PINION
6. TRAIL RACK

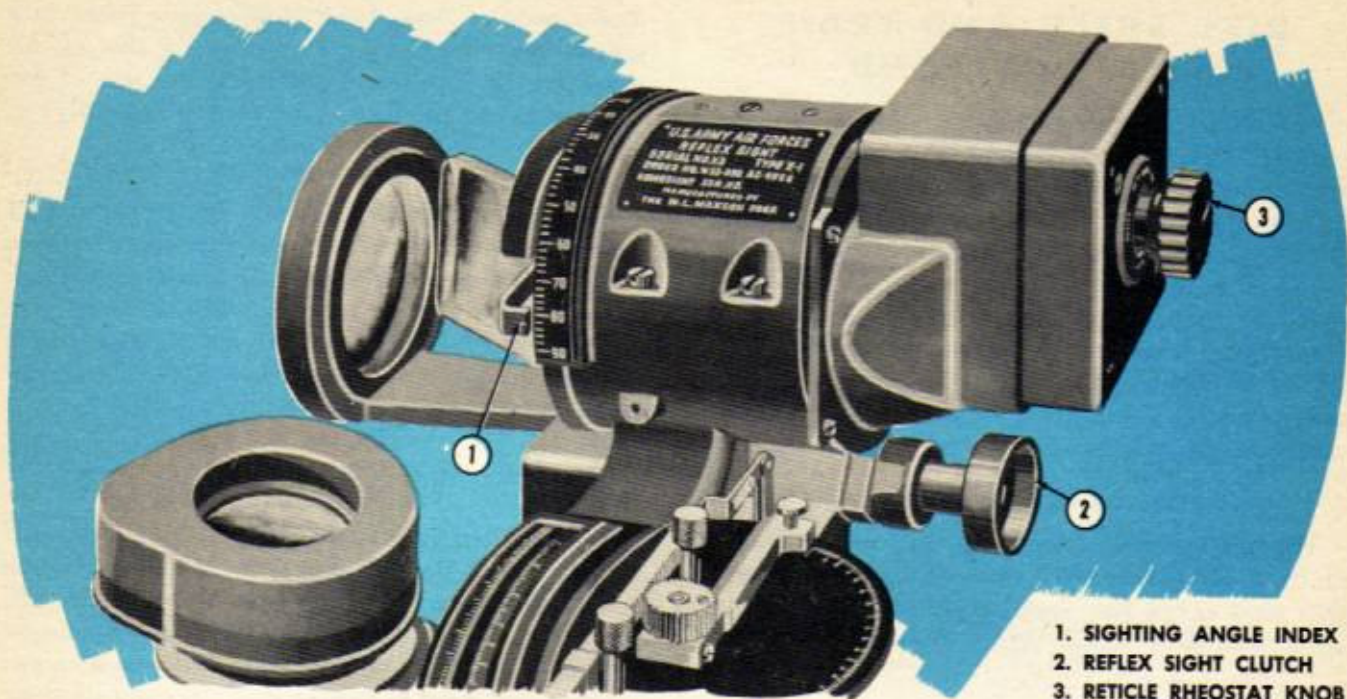

1. SIGHTING ANGLE INDEX
2. REFLEX SIGHT CLUTCH
3. RETICLE RHEOSTAT KNOB

X-1 REFLEX SIGHT

The reflex sight is an auxiliary sighting device for the M-series bombsight. It provides you with a greater field of vision and enables you to make your initial alignment of the bombsight crosshairs on the target in a minimum amount of time. However, you should use the reflex sight only to establish your initial course and range synchronization.

There is a minimum loss of light transmission through the optics of the reflex sight. Thus it is particularly adaptable for bombing at night and at extremely high altitudes when visibility is limited.

The optics of the reflex sight is mechanically geared to the bombsight mirror drive quadrant. Therefore, when you properly engage the optics, the sighting angles indicated by both the reflex sight and the bombsight are identical.

To align the sighting angle indices:

Pull reflex sight clutch to right.

Rotate sighting angle index of reflex sight to same angle as sighting angle index of bombsight.

Engage clutch.

The additional drag of the reflex sight optics on the bombsight's mirror drive mechanism is not enough to cause roller slippage. Therefore you may normally leave the reflex sight clutch engaged after properly aligning sighting angle indices. Make sure indices coincide before you use reflex sight.

The reflex sight is rigidly attached to the bomb-sight housing and the optics is not gyroscopically stabilized. Accordingly, when you align the sighting angle indices, always make certain that the bomb-sight is level after the airplane has been trimmed for normal flight. Cage the vertical gyro and use the leveling bubbles as a reference for adjusting the stabilizer mount. The reflex sight now has the same vertical reference as the bombsight. The crosshairs of both will coincide on an object which is more than 2000 feet away.

The reflex sight does not have a crosstrail mechanism. Therefore if the bombsight is set at any drift angle other than 0° , the reflex sight crosshairs will be in lateral error an amount equal to crosstrail.

The center of the reflex sight optics is several inches above the center of the bombsight optics. In some airplanes, therefore, part of the airplane structure interrupts the line of sight, limiting the sighting angle. Otherwise, the reflex sight may be used for dropping angles up to 70° when engaged with the bombsight. You may obtain an additional 20° by disengaging the reflex sight optics and setting them at the desired angle manually.

A 2-filament lamp illuminates the reticle of the reflex sight. You control the amount of light by rotating the rheostat in either direction from OFF. If one filament burns out, you may utilize the other by rotating rheostat in the opposite direction.



SECTION

7

ARMAMENT . . .

The bombardment airplane is one of the world's most effective offensive weapons. Bombing disrupts and demoralizes enemy forces in the field. It ruins the enemy's industrial front, cripples his communications, and undermines his civilian morale.

As a bombardier your principal task is to control the powerful offensive armament of a bomber. In fact, in many outfits, the bombardier is also his airplane's armament officer. You must know the types of bombs and fuzes required to attack any kind of target with maximum effectiveness. You must know how to inspect, fuze, and load all types of bombs. It is also your responsibility to understand the installation, preflight, and operation of bomb racks and controls and know what to do in case they fail to work properly. This knowledge is necessary to insure successful missions and the safety of the crew.

Because the bomber is such a formidable offensive weapon it has become a target itself and thus needs a defense. Caliber .50 machine guns and gun turrets make up the usual defensive armament. You must know how to load, preflight, and operate them effectively. You must keep them in good condition in order to protect as completely as possible the bomber's striking power.

BOMBS

The aim of any bombardment is to destroy ground installations, personnel, or material; frequently, all three. High explosive bombs usually accomplish this destruction. If you are bombing buildings of substantial construction you drop bombs carrying a heavy charge of explosives. The explosions are timed to occur some feet below ground. The earth shock from this type of explosion does the greatest amount of damage. On the other hand, if the target should be parked airplanes, vehicles, personnel, or insubstantial structures, you want the bomb to explode above or on the surface of the ground.

High explosive bombs require a detonating wave to start their rapid decomposition. This detonating wave is usually started with a primer, made from a highly sensitive but not too powerful explosive. The wave is built up by additional explosive charges of increasing power and decreasing sensitivity. The result is a strong detonating wave setting off a powerful but relatively insensitive bursting charge. The detonating wave is produced by successive action of primer, delay (when used), detonator, booster, and burster charges. Use of delay element is optional.

High Explosives

High explosives generally used in bombs and fuzes: **TNT**, used mainly as a bursting charge in bombs and in high explosive cannon shells. It is an extremely powerful explosive relatively insensitive to heat, shock, and stab action.

Amatol, a mixture of ammonium nitrate and TNT. It is used as a bursting charge for bombs in 50/50 or 80/20 mixtures. The first figure of each mixture represents the percentage of ammonium nitrate used.

Explosive D, used as a bursting charge in armor-piercing bombs and cannon shells. A detonating wave is the only means of igniting it.

Composition B (RDX), used in percentage in all general purpose bombs. It explodes faster and more violently than TNT.

Torpex, used in depth bombs. It is a powerful explosive especially well suited for underwater use.

Tetryl, used as a booster and a burster in chemical bombs. It is the most powerful military explosive.

Mercury Fulminate, used in detonators for bombs and shells. It is the most sensitive but least powerful military explosive. Highly sensitive to heat, shock, stab action, or friction, it is an ideal detonator.

Lead Azide, sometimes used in place of mercury fulminate. It has the same characteristics but is not quite so sensitive to stab action.

Primer Mixture, composed of ground glass mixed with a sensitive explosive. It produces an explosive flash that insures ignition of the detonator.

AN-M56A1 4000-LB.
LIGHT CASE BOMB

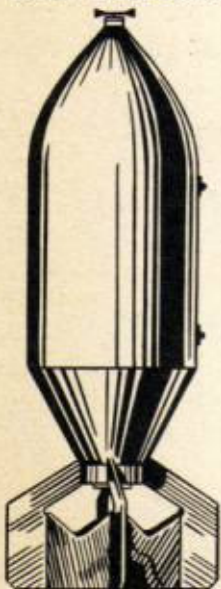

AN-M66A1
2000-LB. GP BOMB

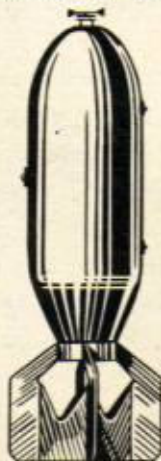

AN-M65A1
1000-LB. GP BOMB



AN-M64A1
500-LB. GP BOMB



AN-M57A1
250-LB. GP BOMB



AN-M30A1
100-LB. GP BOMB



Classification

Bombs are normally classified or typed according to the purpose for which they are designed and the type of filler used.

General Purpose bombs cause destruction by blast and vacuum pressures when they explode above ground, by earth shock when they explode below ground. These bombs are of the AN-M series and resemble each other closely. They differ mainly in size, weight, and weight of explosives.

Light Case bombs, as the name implies, have such light cases that about 80% of the total weight is explosive. The 4000-lb. block buster is a light case bomb and is used to raze areas equal to a city block or more.

Armor-Piercing bombs are used against heavily armored battleships, and against structures of stone or reinforced concrete. They have an extra heavy case and a sharp nose. High explosive comprises about 5 to 15% of their weight.

In order to penetrate the deck armor of modern battleships, armor-piercing bombs must be dropped from a bombing altitude of at least 15,000 feet.

AN-M65A1
1000-LB. GP BOMB

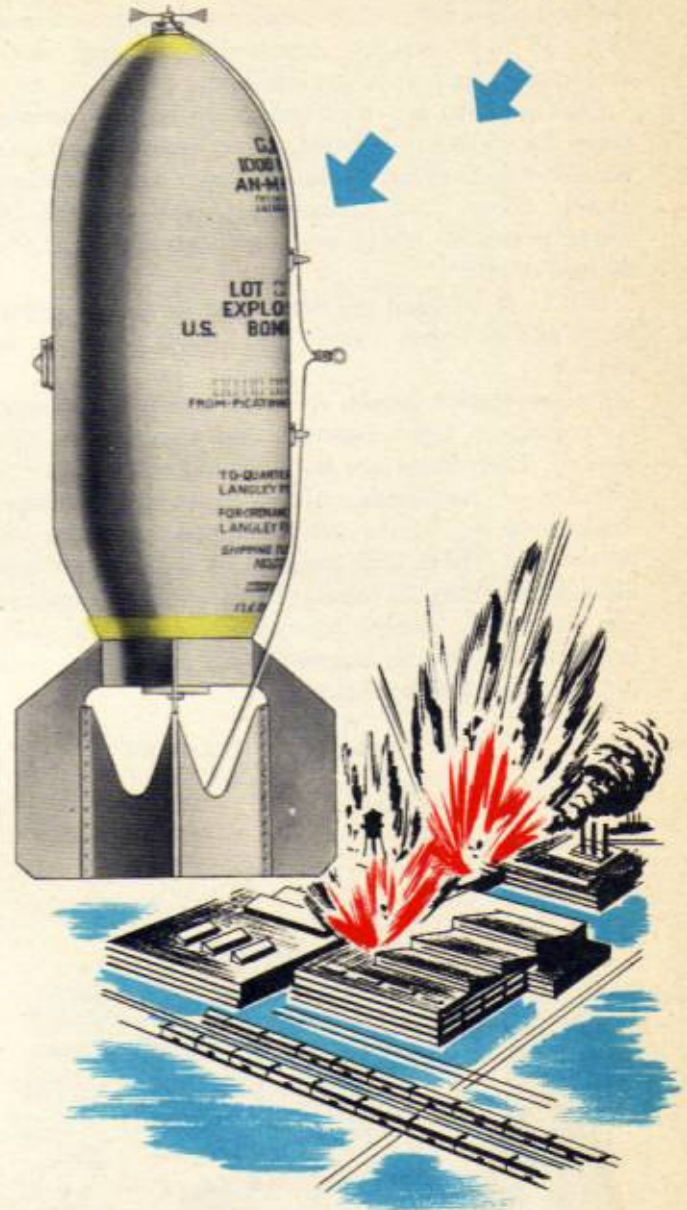

AN-Mk1
1600-LB. AP BOMB

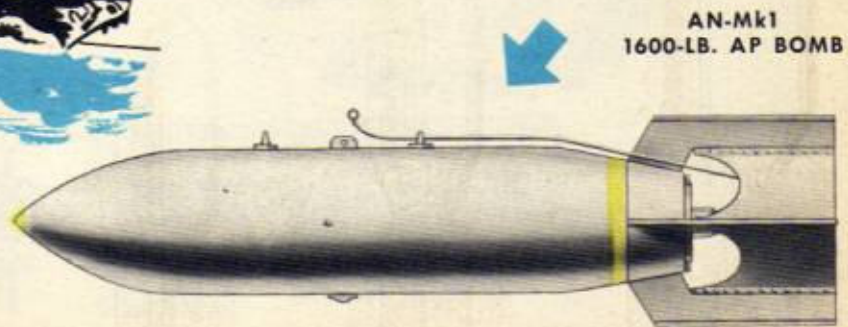

Semi-Armor-Piercing bombs are similar to armor-piercing bombs but cannot penetrate such heavy armor or concrete. High explosive comprises about 30% of their weight. Armor-piercing and semi-armor-piercing bombs use a tail fuze only.

Depth bombs are used primarily against submarines. Exploding under water they create a pressure which tends to crush the hulls of undersea or surface vessels. They have hydrostatic fuzes operated by water pressure, which produces detonation at the desired depth.

If it is to be used for demolition effect the depth bomb is fitted with a nose fuze which functions on impact.

Fragmentation bombs are used chiefly for attacks on personnel, light materiel, and airplanes on the ground. Their cases are built to shatter into a large number of fragments, which cause the damage. Fragmentation bombs are equipped with fins or parachutes. Those with parachutes are used for low altitude bombing, to retard action until the airplane has cleared the danger zone of the bomb. For more concentrated attacks fragmentation bombs are used in 100-lb. and 500 lb. clusters.

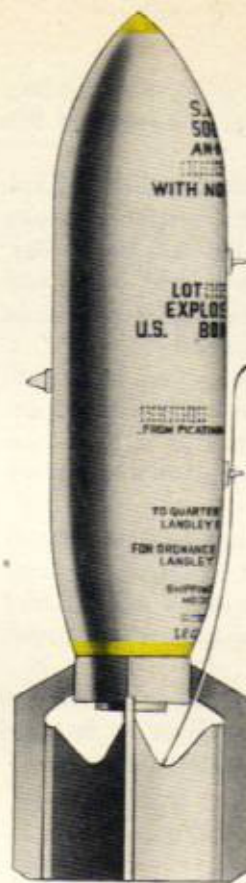

**AN-M58A1
500-LB. SAP BOMB**

**AN-Mk47
350-LB. DEPTH BOMB**

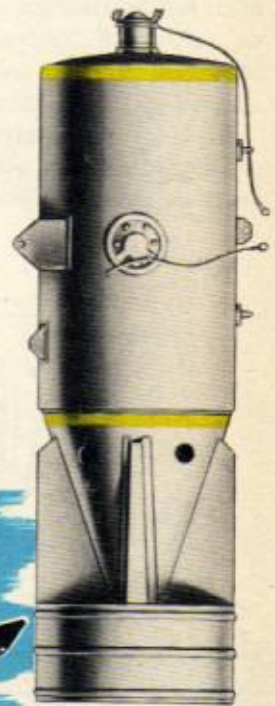

**AN-M40
23-LB. FRAGMENTATION BOMB**

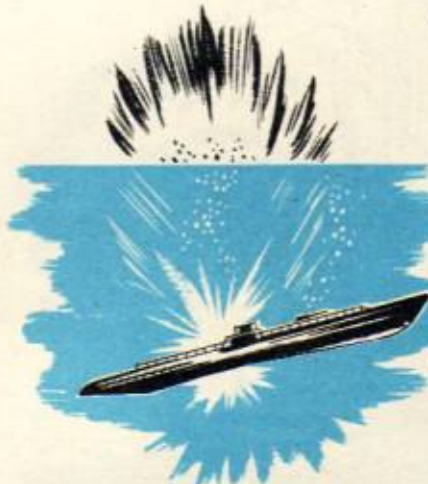

M1A1 100-LB. FRAGMENTATION CLUSTER

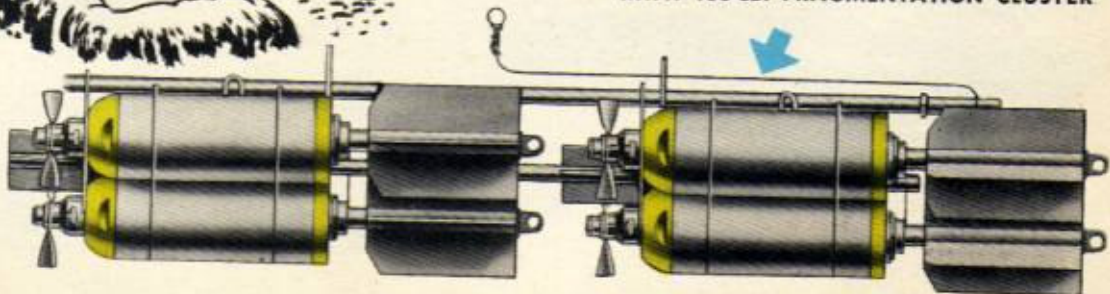

Chemical bombs (gas or smoke) produce irritating or toxic gases or a screening smoke. The gas bombs are classified as persistent or non-persistent. Their contents must be released and mixed with air to become effective. The smoke bombs are filled with white phosphorous or HC mixture.

Incendiary bombs are the most common type of chemical bomb. They contain thermite, magnesium, jelled gasoline, or a combination of thermite and magnesium. They range in size from small bombs of 2, 4, 6, and 10 lbs. to 100-lb. and 500-lb. bombs. The small bombs are used in clusters weighing 100 or 500 lbs. After a cluster is released it breaks open before impact and thus scatters the individual bombs. Incendiary bombs act on impact; a bursting charge of black powder or high explosive scatters the flaming particles.

Inert bombs are used in training. The practice bomb, M38A2, is a 100-lb. bomb filled with sand. It contains a 2.6-lb. spotting charge: M1A1 for photographic or triangulation scoring, M3 for snow-covered targets, or M4 for sonic scoring. Standard inert bombs are called drill bombs, for they are used in training men to assemble, fuze, and unfuze bombs.



M47A2
100-LB. SMOKE BOMB (Phosphorous)

M70
115-LB. GAS BOMB (Persistent)

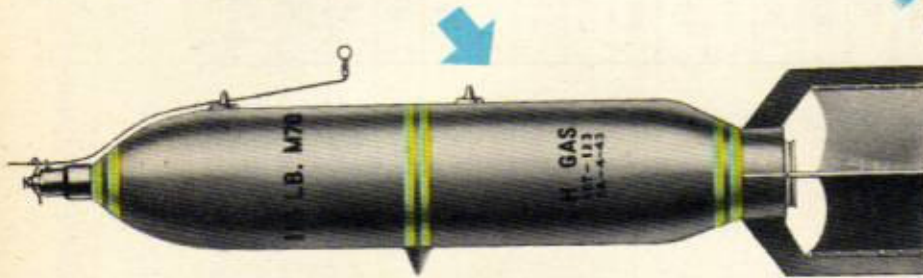

AN-M12
100-LB. INCENDIARY CLUSTER

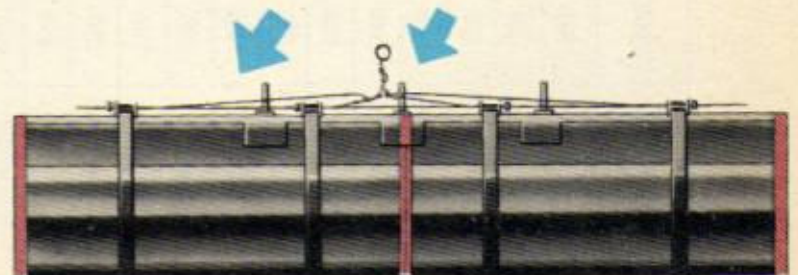

AERIAL BOMBS

CLASSIFICATION	WEIGHT	NOMEN- CLATURE	COLOR MARKINGS		HE WEIGHT	FUZES		SHACK- LES	MINIMUM SAFE BA	TARGETS AND REMARKS
			BODY	BANDS		NOSE	TAIL			
GENERAL PURPOSE	100	AN-M30	LUSTERLESS	(1") YELLOW BAND AROUND NOSE AND TAIL	54	AN-M1003 or M118	AN-M100A2 or M112A1 or AN-M101A2 or M113A1	B-7 or B-10	1500 2000 2500	Railroad equipment, trackage, small buildings, ammunition dumps, planes on ground, hangars Railroad equipment, trackage, RR terminals, ammunition dumps, destroyers, subs, transports Steel railroad bridges, subways, concrete docks, light cruisers
	250	AN-M57			123	M119	AN-M102A2 or M114A1			
	500	AN-M64			262	AN-M103	AN-M102A2			
	1000	AN-M65			530	AN-M103	AN-M102A2	3000	3000	Reinforced concrete bridges, steel RR bridges, piers, approach spans, medium cruisers Massive reinforced concrete and suspension bridges, heavy cruisers, battleships, dams
	2000	AN-M66			1061	AN-M103	AN-M102A2			
	LIGHT CASE	4000			AN-M56			3245	AN-M103	AN-M102A2
SEMI-ARMOR- PIERCING	500	AN-M58A1			145	STEEL PLUG	AN-M101A2	B-7 or B-10		Armor plate, lightly armored vessels, reinforced concrete
	1000	AN-M59			303	AN-M102A2	AN-M102A2			
ARMOR- PIERCING	1000	AN-Mk33			144	NONE	AN-Mk228	B-10		Heavily armored naval vessels
	1600	AN-Mk1			215					
DEPTH	350	AN-Mk47			252	AN-Mk219 or AN-M103	AN-Mk224 AN-Mk234 (LATERAL)	B-7 or B-10		Submarines and surface craft
	650	AN-Mk29			464					
FRAG PARACHUTE	23	AN-M40			2.7	AN-M120A1	NONE	N-3	80	Personnel—if detonated at proper angle, almost 100% casualties over 120 ft. radius Tanks—Running gear, 60-90 ft.; light tank, direct hit Planes—Motor, 60 ft.; wings and tanks perforated, 200 ft.; structural damage, 3-4 ft. Telephone wires—100 ft., some cut by side spray
	20	AN-M41			2.7	AN-M110A1				
	500	M26				M111A2				
CHEMICAL MULTI-PURPOSE	100	M47A2	GRAY	*See Below	68	M108	BURSTER M4	B-7 or B-10		Irritating physiological effect on personnel, neu- tralize areas, contaminate material HS produces irritating physiological effect WP produces screening smoke or incendiary effect Usually in 5 bomb clusters; includes 1 AN-M50XA1 (150 gr. BP burster charge)
	115	M70			64	AN-M110A1	BURSTER M10			
INCENDIARY	4	AN-M50A1		1 PURPLE	1.8	NONE	STRIKER UNIT			
PRACTICE	100	M38A2	BLUE		2.6	NONE	MIA1			Training—22 gage, light sheet metal body, filled with about 80 lbs. of dry sand. Actual weight, 98 lbs.
FLARES (PARACHUTE)	44	M24	GRAY	BLUE		NONE	FRICTION IGNITER	4000-25,000		Target lighting; dropping rate, 11.6 ft./sec.; burns 3-3.5 min.; yellowish tint, 1,000,000 candle power Target lighting; dropping rate, 11.6 ft./sec.; burns 3-3.5 min.; 800,000 candle power
	53	AN-M26								
	16	M8A1								
TORPEDO	2100	Mk13-2			600	EXPLODER MECHANISM	NONE			Emergency landings; can be used for bombing. Burns 3 min.; soft yellow, 400,000 candle power Effective range, 6000 yds.; speed about 40 mph; has 93-98 hp steam and gas turbine engine

*BANDS: (NOSE, TAIL AND CENTER) 1 GREEN, NON-PERSISTENT; 2 GREEN, PERSISTENT; 1 PURPLE, INCENDIARY; 1 YELLOW, SMOKE; 1 RED, IRRITANT SMOKE (Vomiting Gas)

FUZES

A fuze is a mechanical device which sets off a bomb at the desired instant. It starts the explosive train which detonates the burster charge on impact.

There are nose, tail, and lateral fuzes. Lateral fuzes are used in depth bombs only.

Safety requires that a bomb must be incapable of exploding until it is clear of the airplane. Thus fuzes are equipped with an arming device, **vane** or **pin**. The arming vane fuze has a metal vane which the air rotates as the bomb falls. When the vane has rotated a certain number of times it falls from the fuze. This allows the fuze to be armed. The arming pin fuze has a small metal pin which is ejected from the fuze upon release of the bomb or shortly after. The ejection of the pin allows the fuze to be armed.

Incorporated in the explosive train of some fuzes is the delay element. This controls the interval in time between impact and detonation. The time interval ranges from instantaneous to 6 days.

PRECAUTIONS IN HANDLING FUZES

A fuze is dangerous if mishandled. Moreover, mishandling or tampering with a fuze may make it inoperative and cause the bomb to be a dud.

- Never tamper with or try to disassemble a fuze.
- Never force a fuze into the bomb case.
- Never use tools to tighten a fuze.
- Discard all fuzes that are rusted or corroded.
- Never apply pressure to blades of the vane.
- Never hold a fuze by its detonator.

Arming Vane Tail Fuzes (AN-M100A2, AN-M101A2, AN-M102A2)

These fuzes have 4 interchangeable primer detonators: for delays of .025, .01, and .10 seconds and for non-delay. AN-M100A2 is used with 100 and 250-lb. GP bombs and the 260-lb. fragmentation bomb. AN-M101A2 is used with 500-lb. GP, SAP, chemical and incendiary bombs. AN-M102A2 is used with 1000-lb. GP, SAP, and chemical bombs; 2000-lb. GP and chemical bombs, and the 4000-lb. light case bomb. These 3 fuzes differ only in size.

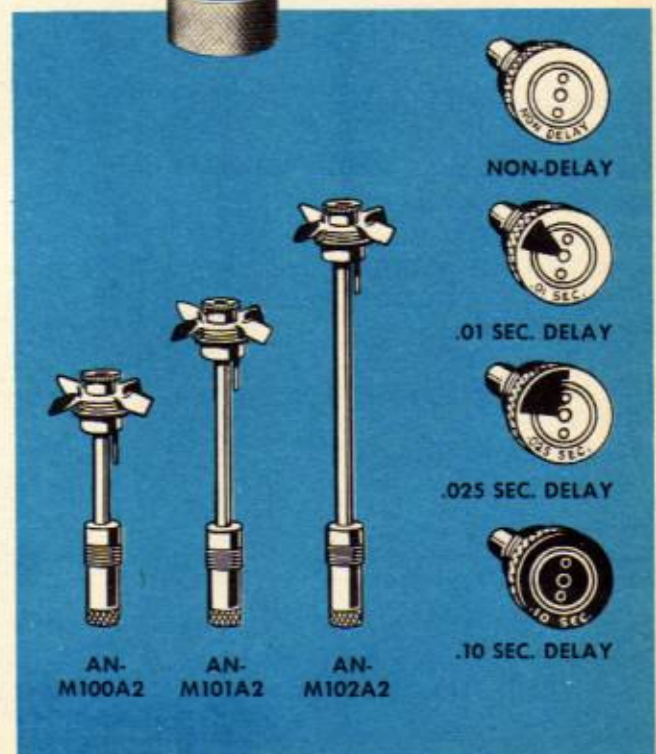
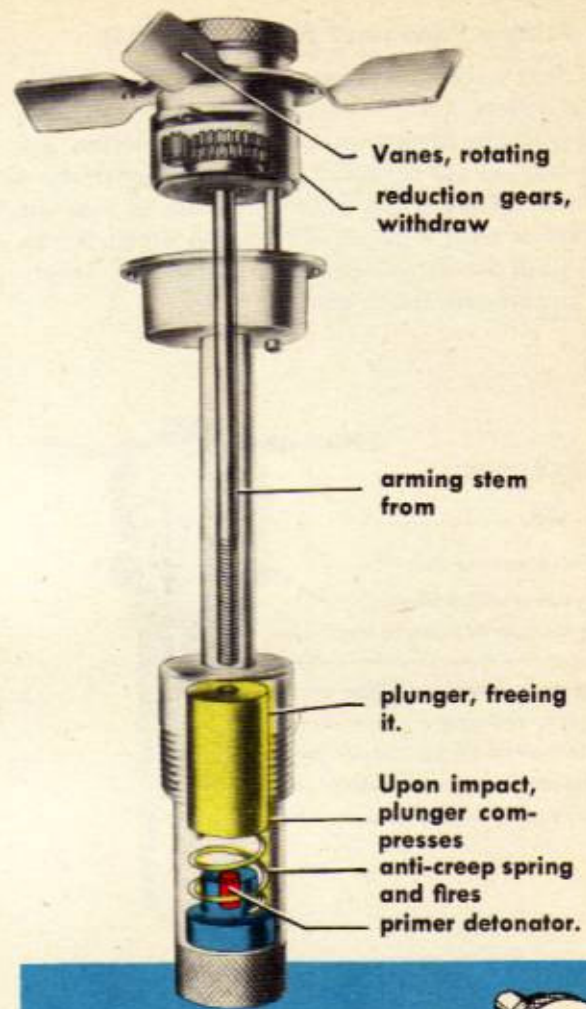

Arming Vane Nose Fuze (AN-M103)

This fuze permits a delay of .1 second or instantaneous action. These 2 settings are made with the setting pin. For instantaneous action the setting pin is pulled as far out of its slot as possible. For delayed action the setting pin is as far in its slot as possible. This fuze is used with all GP bombs, depth bombs (when used for demolition effect), chemical, incendiary, and fragmentation bombs.

DELAYED ACTION

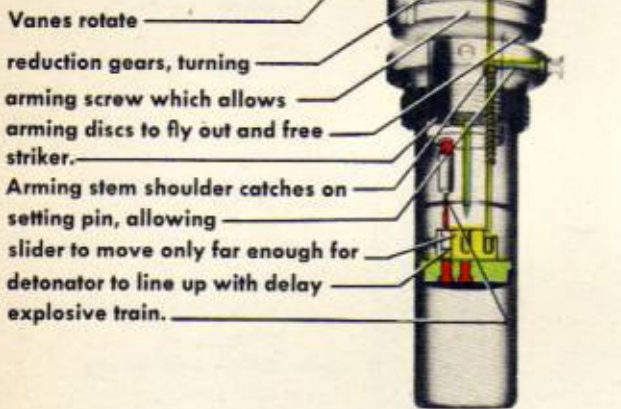

INSTANTANEOUS ACTION

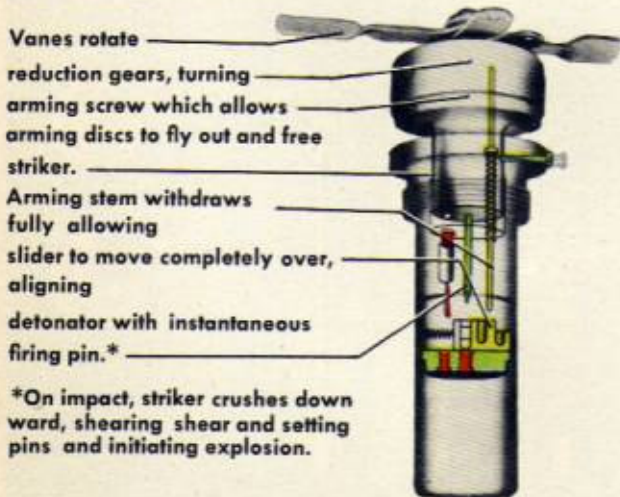

*On impact, striker crushes down ward, shearing shear and setting pins and initiating explosion.

Arming Pin Nose Fuze (AN-M120A1)

This fuze has instantaneous action only and replaces the AN-M104. It has a mechanical arming delay of about 1.9 seconds. It is used on the AN-M40A1 and M72A1 parachute fragmentation bombs (23-lb.).

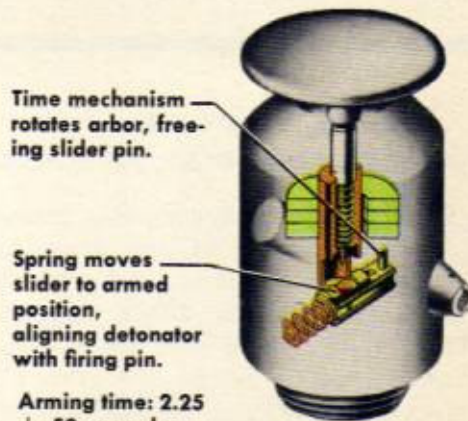
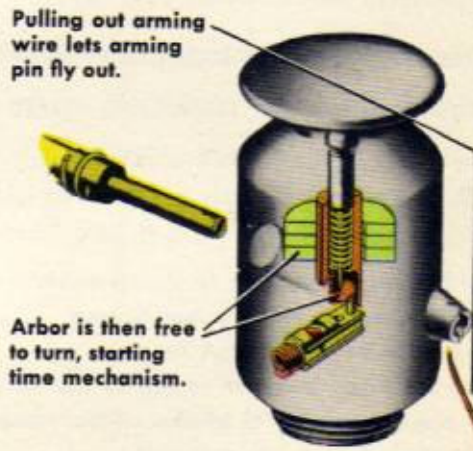
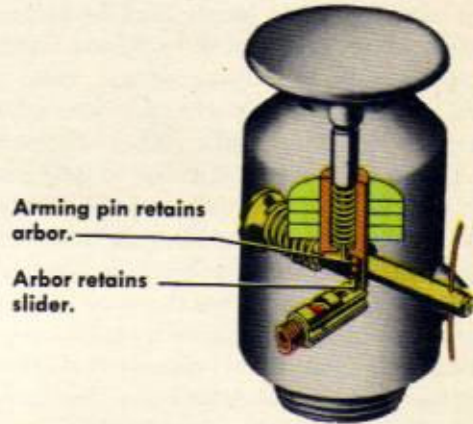

Arming time: 2.25 + .50 seconds.

**Arming Vane Tail Fuzes
(M123A1, M124A1, M125A1)**

These fuzes provide for delayed action of from 1 to 144 hours. The time delay is stamped on the fuze and cannot be seen after the fuze is in the bomb. **Caution: Never unscrew one of these fuzes, for the slightest attempt to do so detonates the bomb.**

The M123A1 fuze is used on 100 and 250-lb. GP bombs. The M124A1 fuze is used on 500-lb. GP and SAP bombs. The M125A1 fuze is used on 1000-lb. GP and SAP bombs and 2000-lb. GP bombs. These 3 fuzes differ only in size.

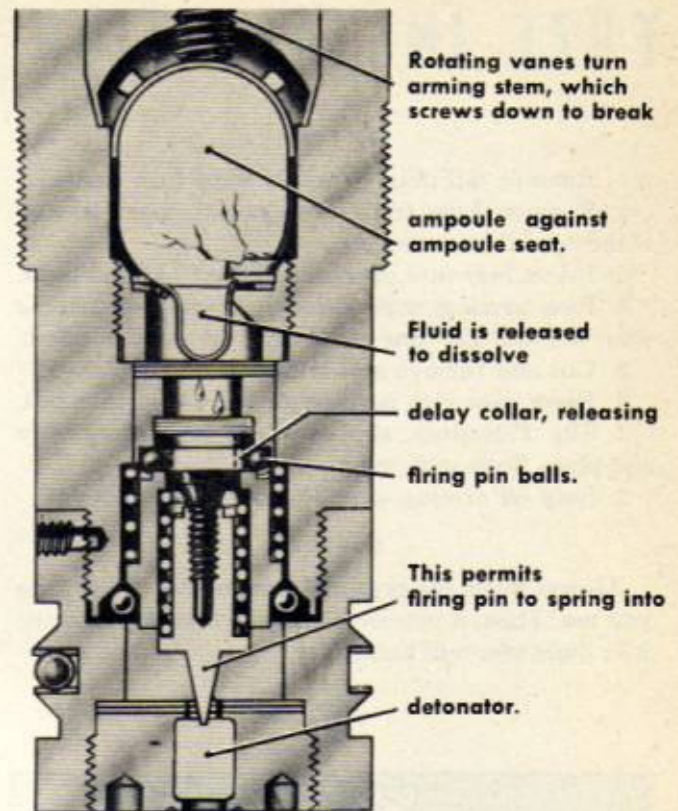
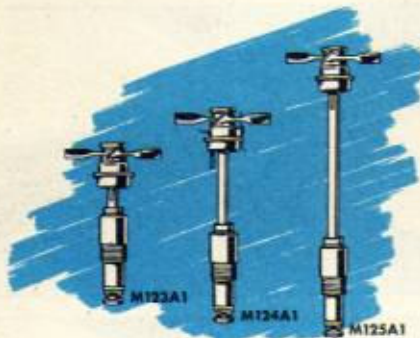

BOMB FUZES

CLASSIFICATION	ARMING	FUNCTIONING	BOMBS USED WITH:
AN-M103	VANE	Selective: instantaneous or .1 sec. delay	All GP, light case, and depth bombs
M108	PIN	Instantaneous	100-lb. M47A2 chemical bomb
AN-M110A1	VANE	Instantaneous	20-lb. FRAG. bomb and 115-lb. M70 gas bomb
M111A2	VANE	5-93 sec. mechanical delay	M46 flare bomb
M118	VANE	4-5 sec. delay	All GP bombs
M119	VANE	8-11 sec. delay	All GP and depth bombs
AN-M120A1	PIN	Instantaneous	23-lb. AN-M40 and 23-lb. M72A1 FRAG. bombs
AN-M126A1	VANE	Instantaneous	100-lb. M47A2 gas bomb
AN-Mk219	VANE	Instantaneous	All depth bombs
AN-M100A2	VANE	Interchangeable primer detonators for non-delay, .01 sec., .025 sec., or .10 sec. delay	100-lb. and 250-lb. GP bombs
AN-M101A2	VANE		500-lb. GP and SAP bombs
AN-M102A2	VANE		1000-lb. GP and SAP, 2000-lb. GP, 4000-lb. light case bombs
M112A1	VANE	Interchangeable primer detonators for 8-11 sec. or 4-5 sec. delay	100-lb. and 250-lb. GP bombs
M113A1	VANE		500-lb. GP and SAP bombs
M114A1	VANE		1000-lb. GP and SAP bombs, 2000-lb. GP bombs
M115A1	VANE	Interchangeable primer detonators for 8-11 sec. or 4-5 sec. delay	100-lb. and 250-lb. GP bombs
M116A1	VANE		500-lb. GP and SAP bombs
M117A1	VANE		1000-lb. GP and SAP, 2000-lb. GP bombs
M123A1	VANE	Marked for delay action of 1, 2, 6, 12, 24, 36, 72 or 144 hours	100-lb. and 250-lb. GP bombs
M124A1	VANE		500-lb. GP and SAP bombs
M125A1	VANE		1000-lb. GP and SAP, 2000-lb. GP bombs
AN-Mk228	VANE	.08 sec. delay	1000-lb., 1600-lb. AP bombs
AN-Mk229	VANE	Hydrostatic; selective depth setting of 25,	500-lb., 1000-lb. GP; light case, and 650-lb. depth bombs
AN-Mk230	VANE	50, 75, 100, or 125 ft.	
M1A1	PIN	Instantaneous	500-lb., 1000-lb., and 2000-lb. GP bombs
AN-Mk224	LATERAL	Hydrostatic; interchangeable firing pin springs *See below	100-lb. M38A2 practice bomb
AN-Mk234			

* For depths of 25 (yellow), 50 (black), 75 (black and green), 100 (yellow and red), and 125 (black and red) feet.

FUZE INSTALLATION

Tail Fuze

1. Remove tail plug; carefully wipe fuze cavity.
2. Remove fuze from container, inspect it, and withdraw safety cotter pin.
3. Insert fuze into cavity and screw in hand tight.
4. Pass arming wire through eyelets of arming wire holder. The fins must now be on the bomb.
5. Cut and remove seal wire.
6. Press vane into position and screw on vane nut.
7. Slip Fahnstock clip over end of arming wire and place flush with vane nut.
8. Snip off arming wire $2\frac{1}{2}$ inches beyond clip.

Caution

Always know the type and functioning of any fuze you use. Then, if you have to make it safe or remove it in flight you will know how.

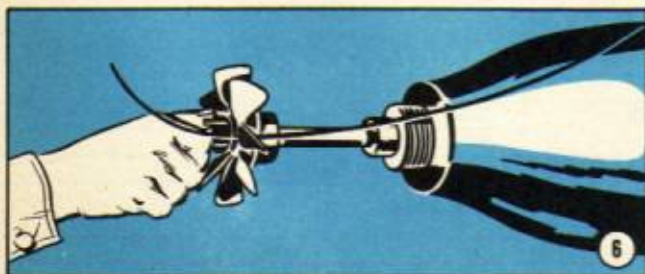

Nose Fuze

1. Remove nose plug and carefully wipe fuze cavity. Make sure no grit or dirt remains in threads.
2. Remove fuze from container and inspect it.
3. Insert fuze into cavity and screw in hand tight. Don't bump detonator against side of cavity.
4. Cut and remove seal wire.
5. Pass arming wire through eyelets of vane stop.
6. Slip Fahnstock clip over end of arming wire and place flush with vane stop.
7. Hold arming vane by hub, press it into position.
8. Snip off arming wire $2\frac{1}{2}$ inches beyond clip.

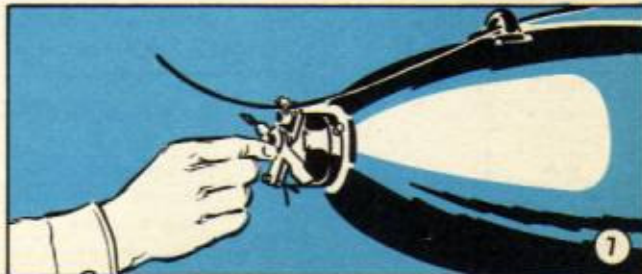

BOMB RACKS AND CONTROLS

The B-17 is widely used on bombing missions in all combat theaters. Typical of all bombers, it has been selected for the following explanation of how bomb racks and their controls operate. B-17 bomb racks and controls are not exactly like those of all other bombers but when you know how they operate you should understand the general operation of others.

The B-17 has both internal and external bomb racks. The internal racks have 42 stations and carry bombs ranging in weight from 100 lbs. to 2000 lbs. Each of the 42 stations is marked to show what weight bombs it can carry. There are 2 external bomb racks, one under each wing. Each can carry one bomb weighing from 1000 to 4000 lbs.

There are 2 kinds of bomb rack control systems, mechanical-electrical and all-electrical.



In bombers which have the mechanical-electrical system you lock the racks, set up the A-2 release mechanisms for normal release, and salvo the bombs manually by means of control handles.

The all-electrical system is the newest type. When you are using it you do not operate the A-4 release mechanisms manually. You make an emergency release (salvo) electrically. All manual controls have been eliminated.

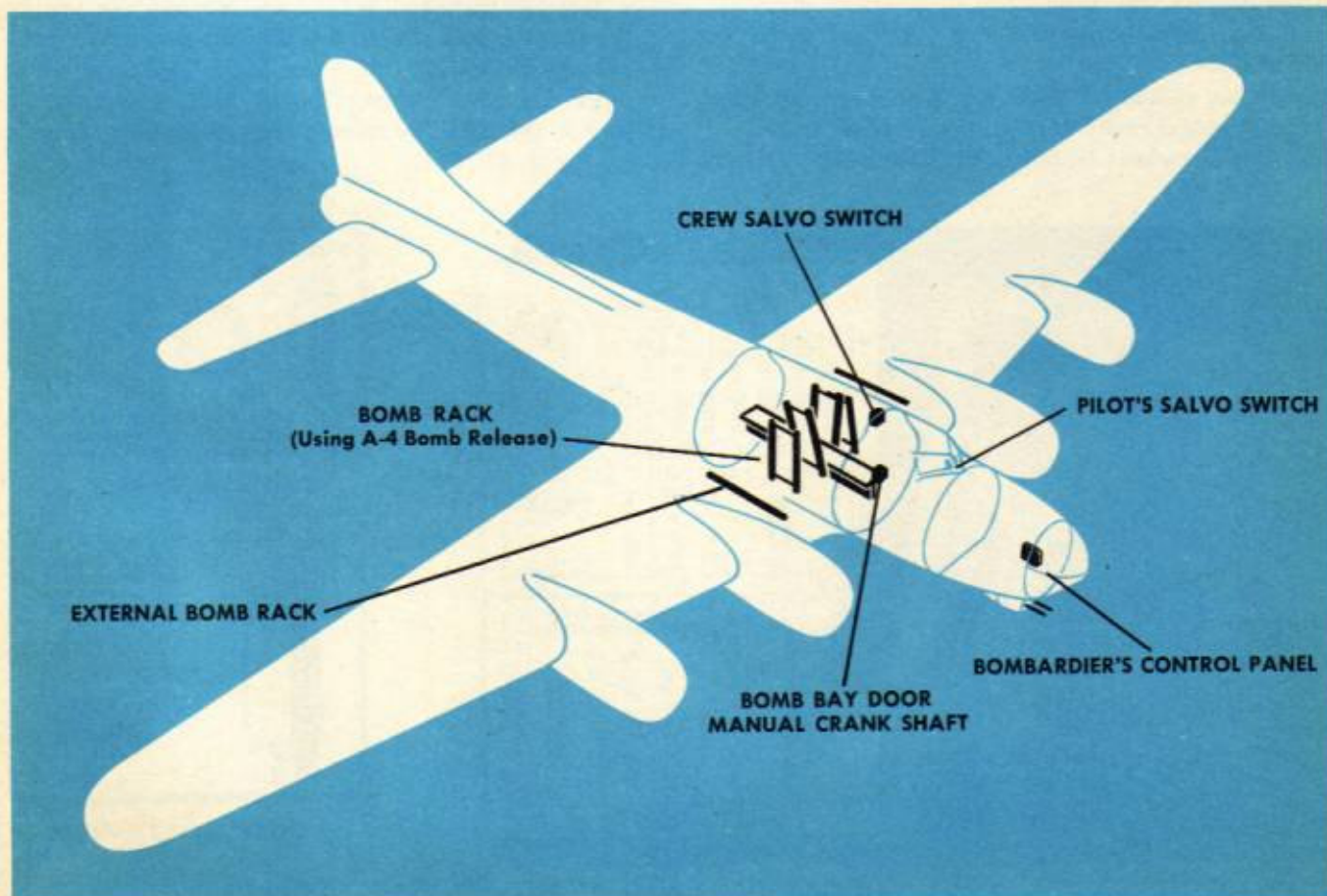

Bombardier's Control Panel

The control panel in the bombardier's compartment contains the necessary switches for bomb release control, the bomb indicator lights, and the intervalometer. This panel is the electrical control center for releasing bombs. You must know every switch and how and when to use it.

The indicator light panel contains one light for each station on the bomb racks. To find out whether all indicator lights are operating, momentarily place the lamp test switch at MOM. All indicator lights should flash on. You can tell at a glance what stations in the bomb bay are loaded by turning the bomb indicator light switch ON for an instant. An indicator light shows for each A-4 bomb release mechanism that is cocked.

Normal Bomb Release (Train)

In train bombing, when you are using the all-electrical control system, make these necessary switch settings:

Master switch ON.

Bomb bay doors OPEN.

Desired rack selector switches ON. When bombs are released they then drop in proper sequence.

Bomb indicator light switch OFF and lamp test switch ON.

Arming switch ARMED, if you wish to drop bomb from external racks with an armed nose fuze.

Intervalometer train-select switch at TRAIN.

When the bombsight automatic release mechanism or bomb release switch completes the electrical circuit an impulse is sent to the intervalometer. The intervalometer in turn sends out one impulse for each bomb to be released. As each release mechanism receives an impulse it operates the bomb shackle. The bomb is released armed.

To release bombs select, you must place the intervalometer train-select switch at SELECT. Set all other switches as you would for train bombing.

Emergency Release (Salvo)

You can release all internal and external bombs safe by placing any one of the 3 salvo switches at SALVO. The light beside each switch indicates that one or more of the salvo switches are closed. The closing of any one switch opens the bomb bay doors electrically in about 12 seconds. When the doors are completely open, an electrical impulse goes to the A-4 release mechanisms on the bomb racks. They operate the bomb shackles which salvo the bombs. The entire operation takes about 15 seconds. In the event of an electrical failure you must open the bomb bay doors by means of a hand crank and release each bomb manually and individually.

The two external bombs are salvoed the instant the salvo switch closes. It is obvious that these racks are not dependent upon the bomb bay door being open. To salvo external bombs safe, place arming switch at SAFE. To salvo them armed, place arming switch at ARMED.

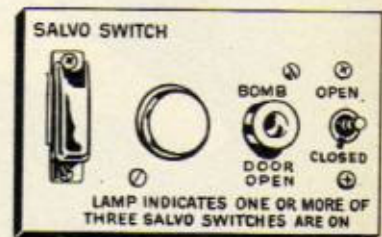
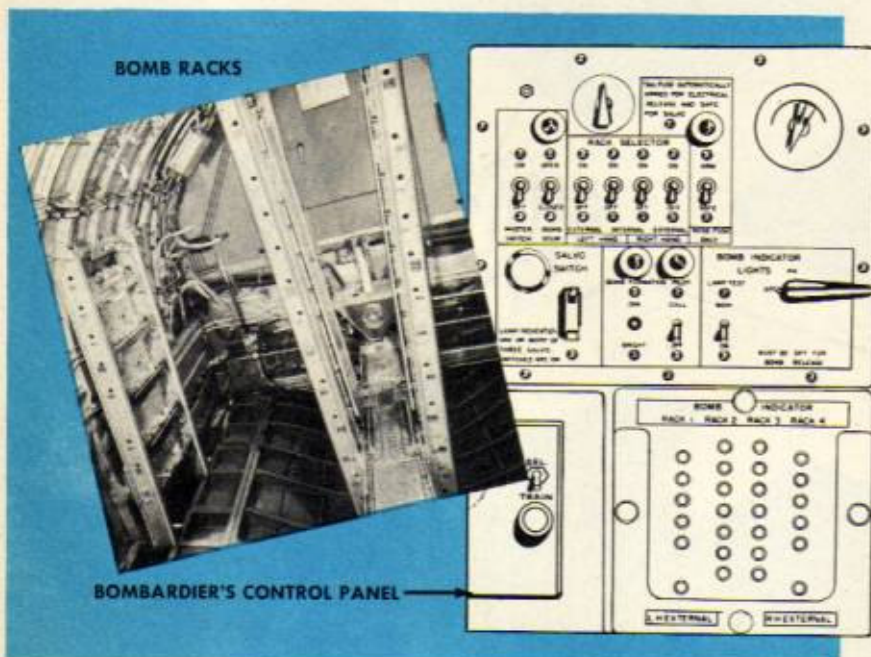

PILOT'S SALVO SWITCH

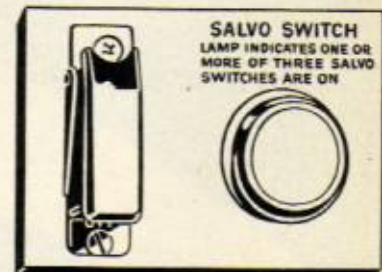

CREW SALVO SWITCH

BOMB RELEASE MECHANISMS

The bomb release mechanism is an electrically operated mechanical device designed to cause the bomb shackle to release and arm a bomb.

A-4 Bomb Release

In order to release bombs select or in train the bombardier's master switch must be ON, bomb bay doors OPEN, and the rack selection made. The electrical impulse from the bomb release switch or the bombsight automatic release mechanism energizes the rotary solenoid inside the A-4. The solenoid rotates to the select position; this trips the release lever and the arming lever.

Bombs are salvoed electrically, not manually. To salvo bombs place the salvo switch at SALVO. The solenoid rotates to the salvo position and only the release lever is tripped.

To operate the A-4 manually, turn the trip screw (marked TRIP) on the front of the A-4 in the direction indicated. This affects the rotary solenoid like an electrical impulse, tripping both release lever and arming lever. When an A-4 has been cocked by mistake the trip screw permits tripping.

The fork of the release lever has one hinged ear. You can release bombs by prying the bomb shackle

release lever over the hinged ear. This method of releasing a bomb safe is used when the A-4 is jammed, preventing normal operation.

Caution

The indicator light switch must be OFF while bombs are being released. If it is ON, a partial salvo results.

When release is tripped manually, trip screw should always be returned to vertical position or it will be impossible to cock release.

Do not apply current to solenoid continuously for more than 30 seconds.

A-2 Bomb Release

This bomb release has the same purpose as the A-4. In order to release bombs the bombardier's master switch must be ON, bomb bay doors open, rack selection made, and release handle placed at SELECT. The electrical impulse operates the solenoid which first causes the arming lever and then the release lever to be tripped.

When using the A-2, you salvo the bombs manually. Place the release handle in your compartment at SALVO. This mechanically operates the release.

The A-2, like the A-4, has a trip screw on the front and a hinged ear on the release lever.

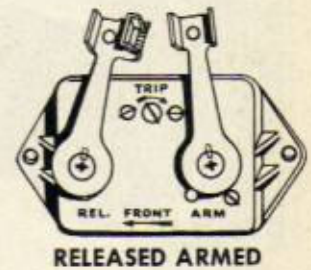

BOMB SHACKLES

Bomb shackles carry, arm, and release bombs. They are attached to the bomb and hung on the shackle suspension hooks of the bomb rack. If this is done correctly, arming lever and release lever are properly positioned in bomb release mechanism.

B-7 bomb shackles carry bombs ranging in weight from 100 to 1100 lbs. They are designed for internal bomb racks but can be used externally with specially constructed adapters.

The word **FRONT** is marked on the frame as a guide to correct installation of the shackle in the bomb station. In the reverse position the shackle will not fit on most bomb racks. Special care must be taken in the B-17F and B-29 for their bomb racks are symmetrical and it is possible to install shackles backwards in them.

The shackle release lever has 2 positions, **COCKED** and **RELEASED**. When it is cocked the carrying hooks cannot open. When it is released the locking mechanism of the shackle disengages, allowing the bomb to pull the carrying hooks open.

The shackle arming lever also has 2 positions, **SAFE** and **ARMED**. When the arming lever is safe,

the release of a bomb pulls the arming wire out of the shackle. When the arming lever is armed, the arming wire is locked so that it cannot leave the shackle; upon bomb release the arming wire is pulled from the fuze.

B-10 bomb shackles are similar in operation to the B-7. They are used interchangeably, except that the B-10 must be used to carry 1600-lb. bombs.

D-6 and D-7 bomb shackles carry 2000 and 4000-lb. bombs and are similar in operation. However, they are not entirely interchangeable. Whenever a D-6 or D-7 is to be used, check the airplane T.O. to make sure that the correct shackle is chosen for the bomb and bomb station being loaded. If you use a D-6 to carry a 4000-lb. bomb when the airplane T.O. calls for a D-7, it will place too much stress on the D-6 shackle. The D-7 cannot be hung satisfactorily on racks designed for the D-6.

B-9 bomb shackles are used to carry bombs with one lug. These bombs may weigh up to and including 1000 lbs. The B-9 operates quite like the B-7.

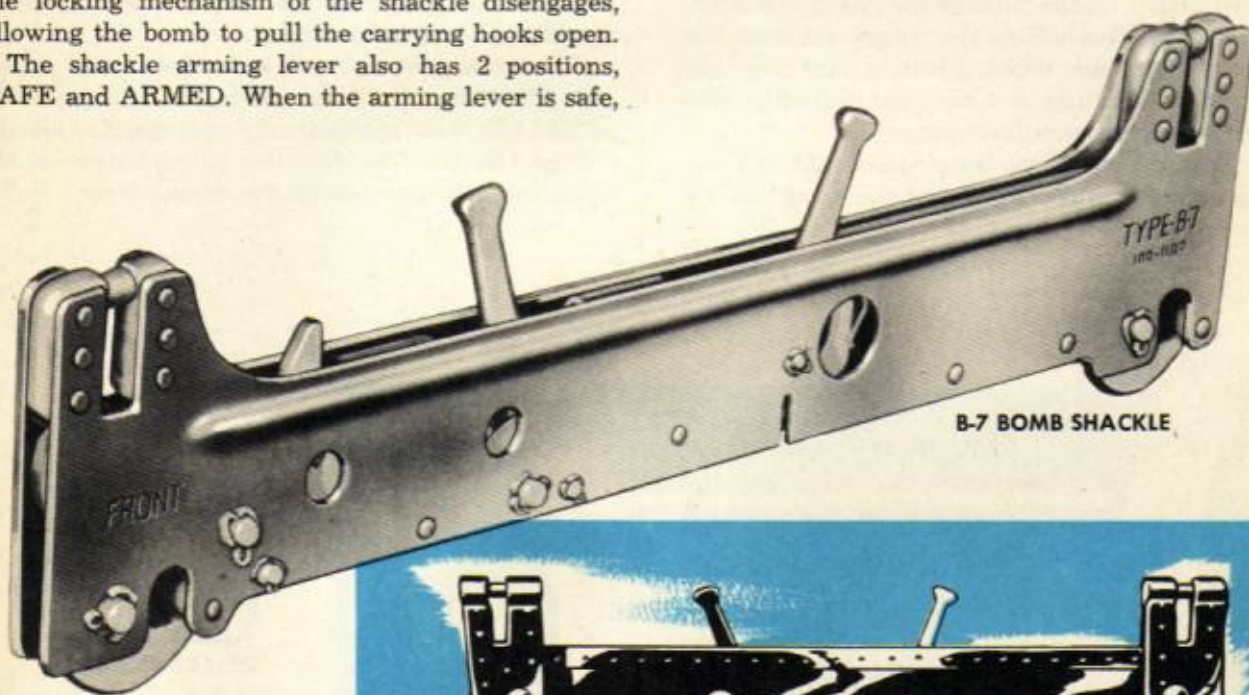

B-7 BOMB SHACKLE



B-10 BOMB SHACKLE



D-6 BOMB SHACKLE

BOMB ARMING CONTROLS

A-2 bomb arming controls provide selective arming of bombs. They are attached to the bomb racks, operated by an arming switch in your compartment, and enable you to salvo bombs armed or safe.

Two arming wires are used, one for the nose fuze and one for the tail fuze. The nose fuze arming wire loop is placed in a catch on the arming control. The tail fuze arming wire loop is inserted in the bomb shackle. The tail fuze is always armed by the bomb shackle for selective and train releases and made safe for salvo release.



A-2 BOMB ARMING CONTROL

To salvo bombs armed, place arming switch at ARMED. Upon bomb release the arming control holds the nose fuze arming wire; thus it is pulled from the nose fuze as the bomb falls. The nose fuze then is armed; the tail fuze remains safe.

To salvo bombs safe, place arming switch at SAFE. Upon bomb release the nose fuze arming wire is pulled from the arming control and falls with the bomb. Both nose and tail fuzes are safe.

CARE OF BOMB RACKS AND CONTROLS

The care of bomb racks and equipment pertaining to them consists principally of keeping them free of dirt and grit. It also includes replacement of any parts of equipment found to be in faulty or questionable condition.

Never use grease or oil on bomb racks or controls. Such products congeal at the low temperatures of high altitudes. This causes equipment to work sluggishly and may result in operational failure. Clean bomb racks and shackles with kerosene. Clean all corroded parts with emery cloth.

The release mechanisms are designed to operate without periodic lubrication. Clean all internal parts with a clean dry cloth. Never use kerosene on any internal part of the A-4 bomb release. It is injurious to the electrical solenoids.

BOMB HOIST

The C-3A bomb hoist assembly consists of 2 separate hoists which operate together. It hoists a bomb into position and rolls it slightly to assist in attaching shackles to the bomb rack.

This bomb hoist can be operated either manually or electrically. It is a part of the standard bombing equipment of A-26, B-17, B-24, and B-29 airplanes. It is designed to be used in hoisting bombs weighing as much as 2000 lbs. Two C-3A bomb hoist assemblies are required to hoist 4000-lb. bombs.

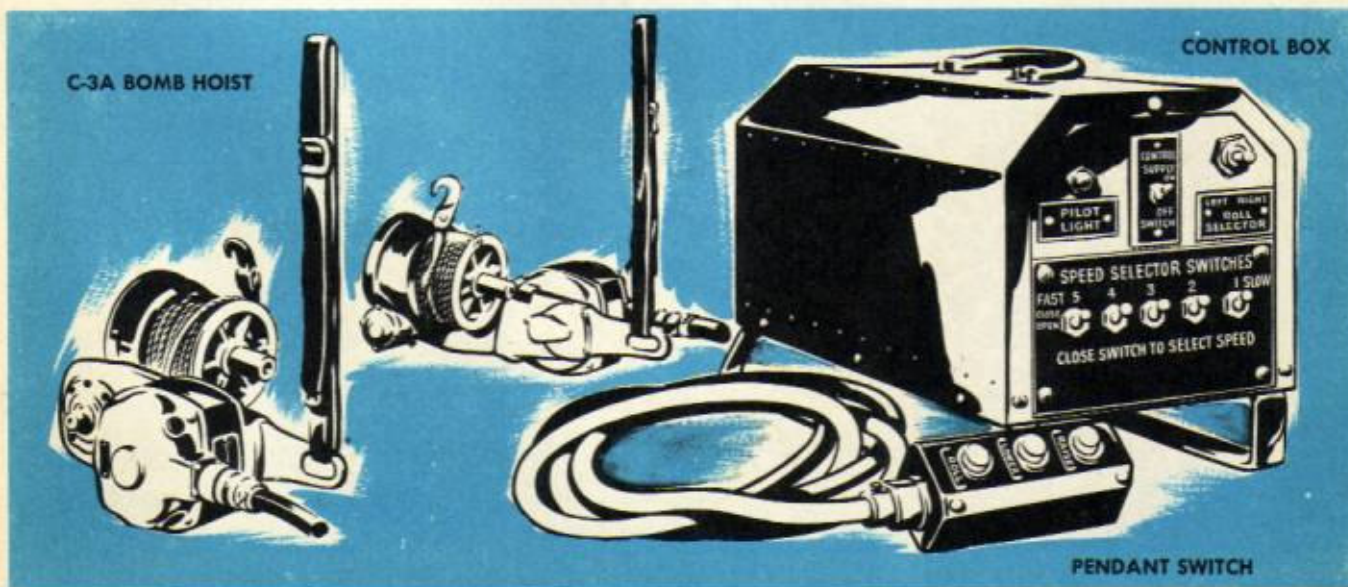

C-3A BOMB HOIST

CONTROL BOX

PENDANT SWITCH

INTERVALOMETER

The intervalometer provides a method of releasing in train a predetermined number of bombs with a predetermined space interval between successive impacts. The space interval in feet between bomb impacts depends on the groundspeed of the airplane and the time lapse between bomb releases. The number of bombs to be released depends upon the target.

In train bombing, the first bomb impact should be placed so that the center of the train of bombs will hit the center of the target. The train bombing equation converts to mils the number of feet by which the first bomb must hit short of the target. Either by reducing the trail or DS you can place the first impact the desired number of feet short.

Reducing the trail causes an appreciable cross-trail error, unless your bombsight is equipped with a trail spotting device.

To find how much to reduce the DS:

Double the GS and divide it by 100.

Divide the result into the number of mils needed to place the first bomb impact the proper distance short of the target.

The answer is the number of rpm to decrease DS.

Operation

When train bombing, set train-select switch at TRAIN and set counter knob pointer at number of

bombs desired in train. Determine GS you expect to have over the target and set it opposite desired bomb spacing. Do all this before reaching IP. After releasing a train of bombs the counter knob pointer is at 0 and the intervalometer is OFF.

For selective release put train-select switch at SELECT. To turn intervalometer OFF, set counter knob pointer at 0 and train-select switch at TRAIN.

Calibration

Set train-select switch at TRAIN and counter knob pointer at 50. Set 500 mph on groundspeed dial opposite 750 feet on interval dial. Allow at least one minute for intervalometer to reach operating temperature. Determine time required for counter knob pointer to reach 0 after you push bomb release switch. It should take from 45 to 55 seconds. If it takes more than 55 seconds, turn calibration screw on back of intervalometer clockwise. Turn screw counter-clockwise if it requires less than 45 seconds for counter knob pointer to reach 0.

Caution

At least one minute prior to release, set train-select switch at TRAIN and counter knob pointer at required number of bombs.

Turn intervalometer OFF when not in use.

Make sure intervalometer is calibrated accurately before takeoff.

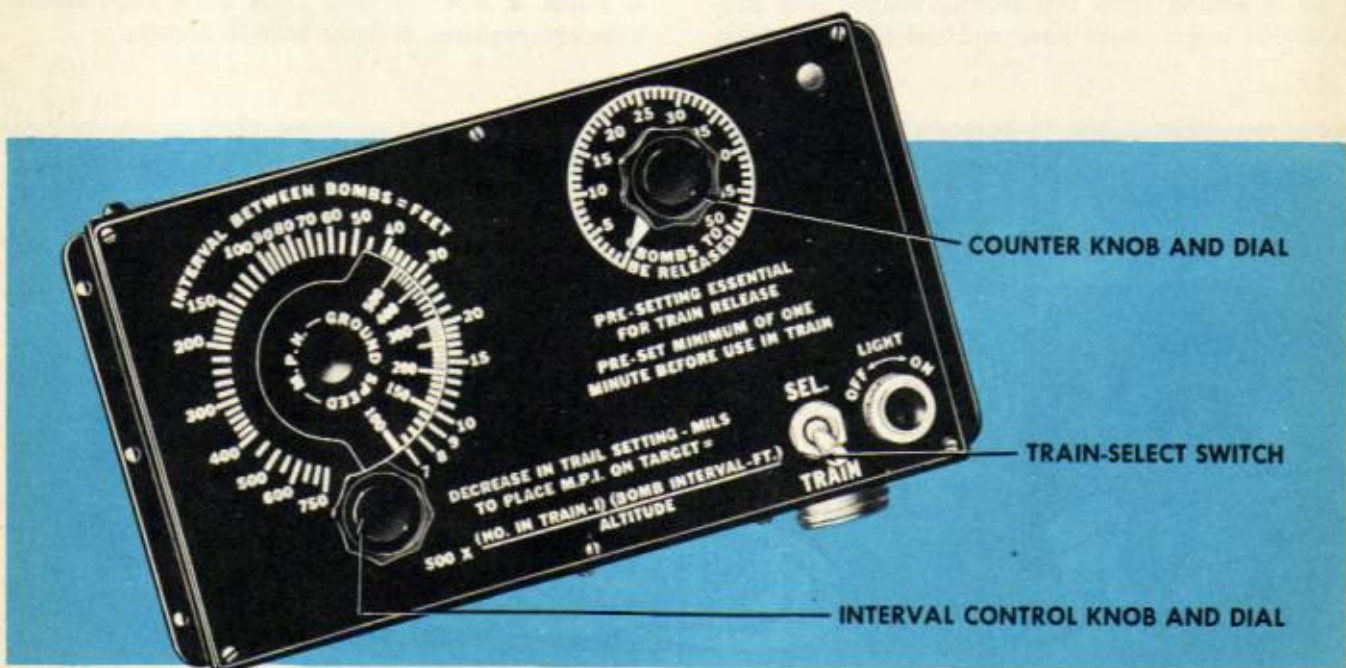

PREFLIGHT PROCEDURE



Before Loading Bombs

1. Turn main line switches and bombardier's master switch ON.
2. Check operation of bomb bay doors and bomb bay door safety switches. Also see that excessive grease is off bomb bay door screws.
3. Check to see that all bomb bay switches are at proper positions.
4. Turn rack selector switches ON.
5. Cock all bomb releases and check for their proper attachment and cleanliness.
6. Make sure that all indicator lights are ON.
7. Check to see that indicator light is ON when intervalometer is set up for SELECT or TRAIN.
8. Check release of all stations with bomb release switch and bombsight release mechanism. Indicator lights should go out in proper order.
9. Cock all stations and release stations with intervalometer at TRAIN. Make sure that it is properly calibrated.
10. Cock all stations again and check operation of emergency salvo.
11. Recock only stations to be loaded with bombs.
12. Turn all switches OFF and make sure racks are locked.
13. Make sure shackles operate properly before attaching to bombs; when on bombs see that they are attached properly.
14. Check to see that there are no kinks or bends in arming wire.
15. Make sure that there are no bad dents in bombs or fins and that fin is attached firmly to bomb.
16. Check cotter pins in nose and tail fuzes.
17. Make sure that arming wire extends 2 to 3 inches from end of fuzes and that Fahnstock clip is securely attached and flush with fuzes.
18. Check for security of bomb hoists to rack and see that hoisting cables are free from frays.
19. Make sure that proper sling is used in hoisting bombs and that it is in good condition.

After Loading Bombs

1. Check bombs and shackles to see if they are properly loaded.
2. Check to see if proper stations are loaded.
3. Make sure that release mechanisms on unloaded stations are not cocked.
4. Check to see if bomb indicator lights correspond to stations loaded.
5. Make sure that all switches are OFF.

B-24

BOMB RACKS AND CONTROLS



AUXILIARY BOMB BAY DOOR RELEASE HANDLE

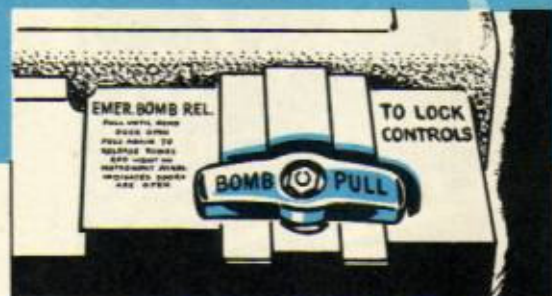

PILOT'S EMERGENCY BOMB RELEASE

MECHANICAL-ELECTRICAL BOMB RACK CONTROL SYSTEM

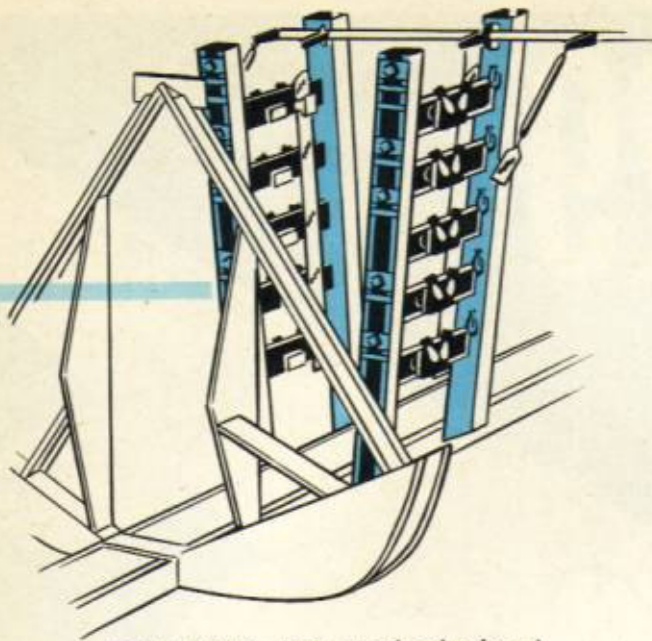

BOMB RACKS (Using A-2 bomb release)

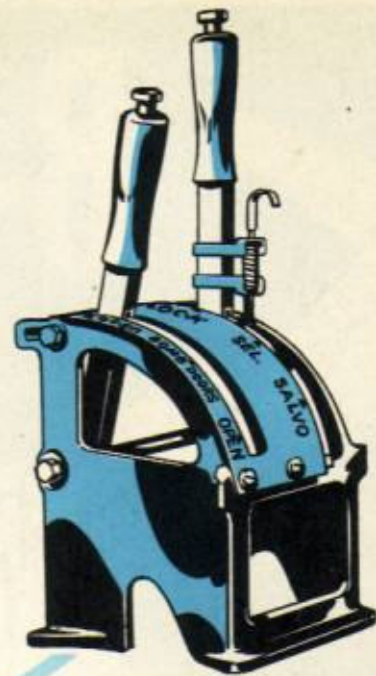

BOMBARDIER'S CONTROL STAND

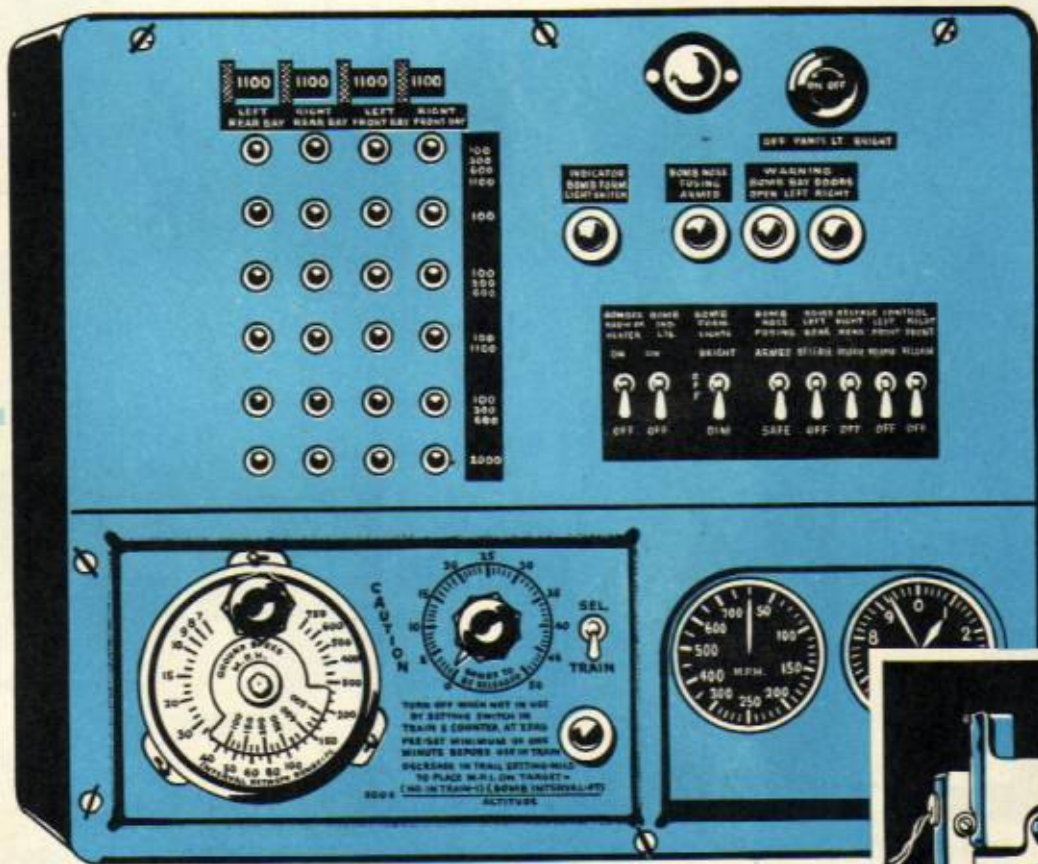

BOMBARDIER'S CONTROL PANEL AND BOMB RELEASE SWITCH

B-29

BOMB RACKS AND CONTROLS



CREW SALVO SWITCH

BOMB BAY DOOR CATCH
(Operated by manual
bomb bay door release)



BOMB HOIST



PILOT'S SALVO SWITCH



EMERGENCY BOMB BAY DOOR RELEASE

ALL-ELECTRICAL BOMB RACK CONTROL SYSTEM

BOMB RACKS (Using A-4 bomb release)

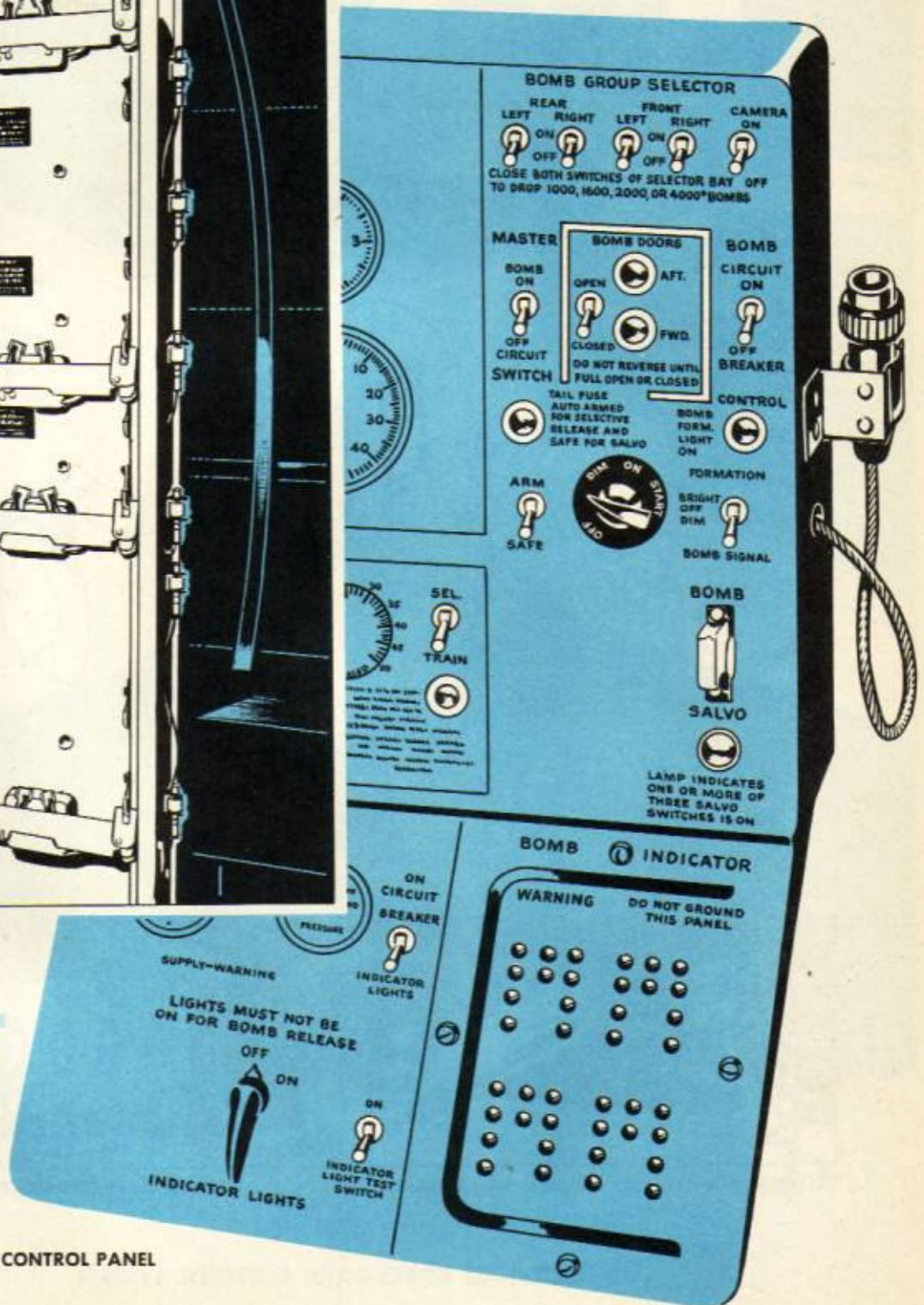
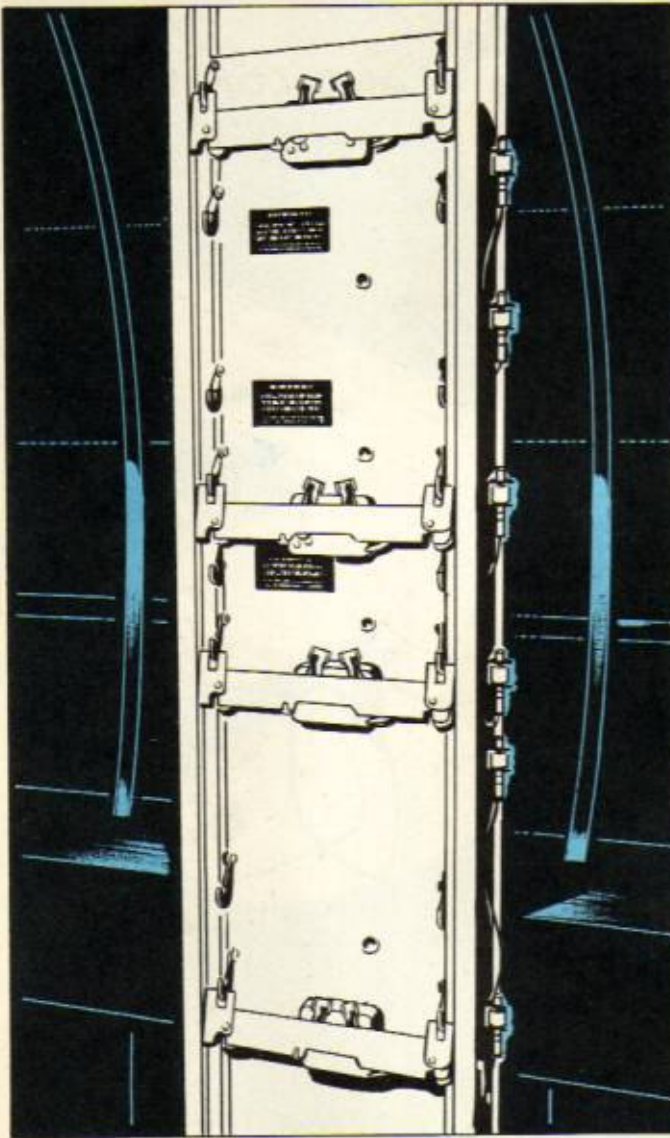

BOMBARDIER'S CONTROL PANEL

A-26

BOMB RACKS AND CONTROLS

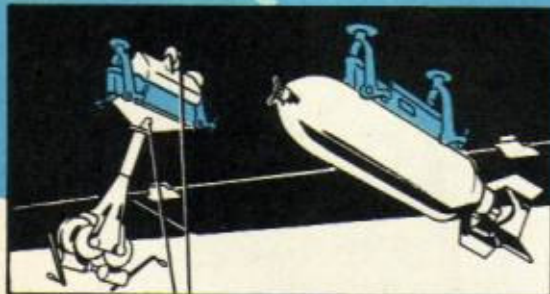

EXTERNAL BOMB RACKS (With bomb hoist type C-3)

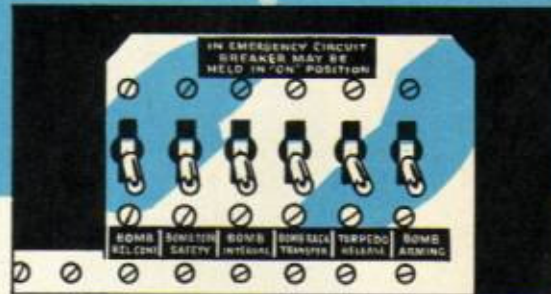

SECTION OF PILOT'S SWITCH PANEL

ALL-ELECTRICAL BOMB RACK CONTROL SYSTEM

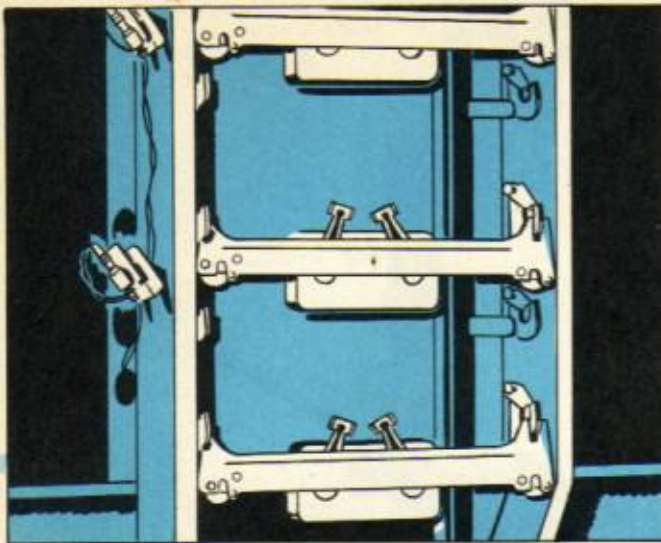

BOMB RACKS (Using A-4 bomb release)

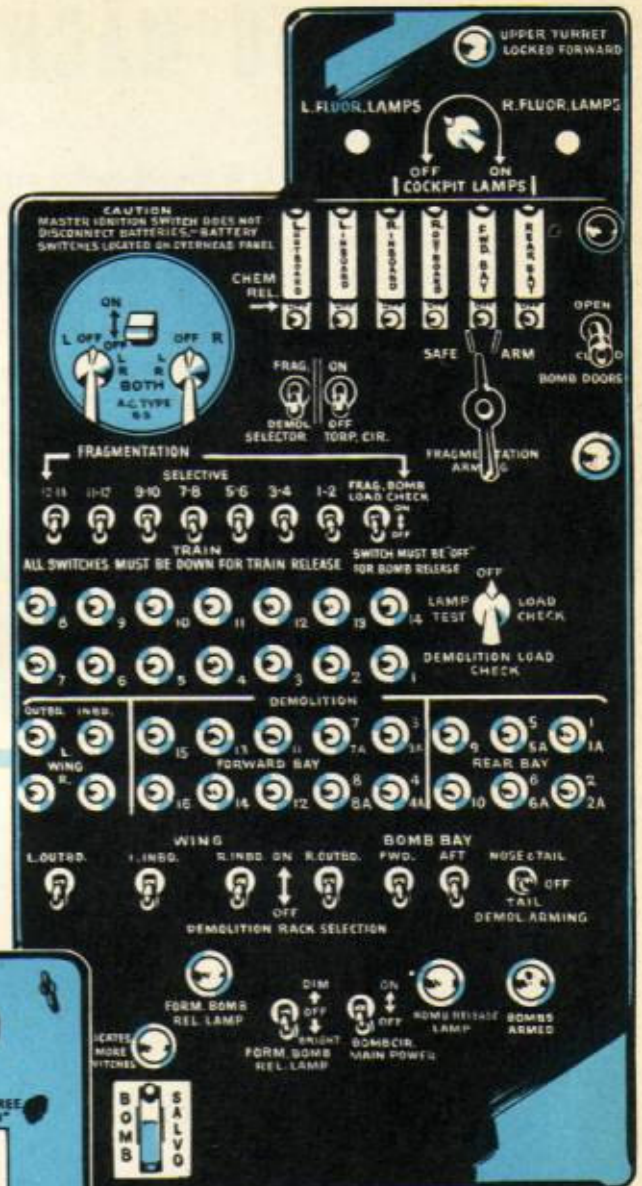

PILOT'S CONTROL PANEL

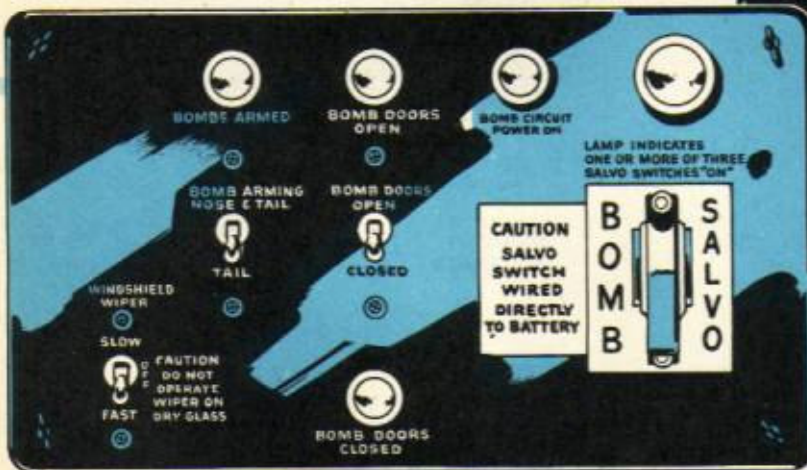

BOMBARDIER'S CONTROL PANEL



CALIBER .50 MACHINE GUN

The standard U.S. aerial gun is the air-cooled caliber .50 Browning machine gun. It fires 750 to 850 shots a minute at a muzzle velocity of 2900 feet a second. Given proper care and adjustment, this gun performs better than weapons of comparable caliber and weight used by any other nation. At least 95% of all malfunctions can be traced to improper maintenance or lack of training on the part of the operator.

Since the bombardier usually mans the forward guns in a bomber, he must know the operation, adjustment, care, and cleaning of those weapons.

1. BACK PLATE GROUP
2. BOLT GROUP
3. OIL BUFFER GROUP
4. BARREL GROUP

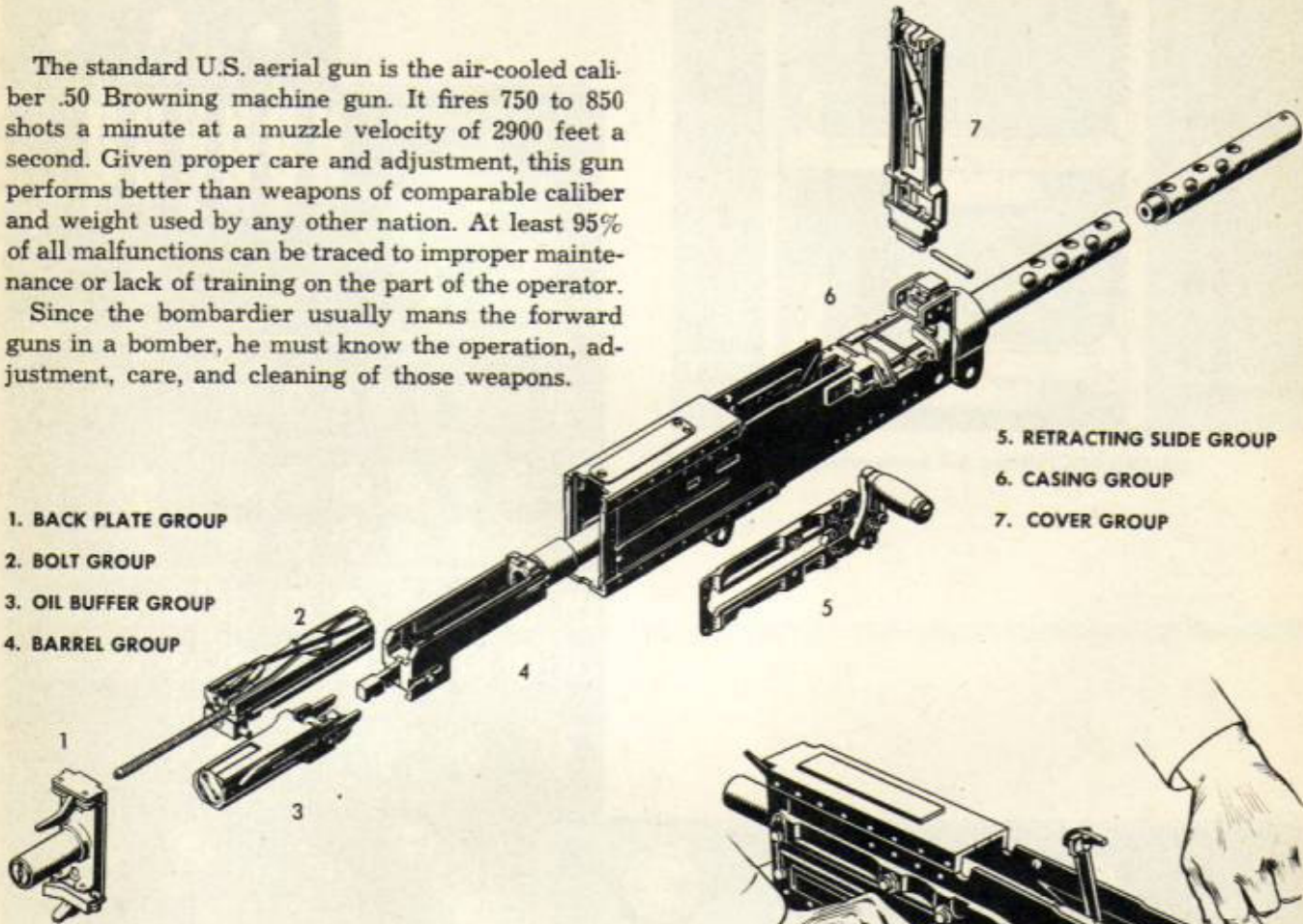

5. RETRACTING SLIDE GROUP
6. CASING GROUP
7. COVER GROUP

ADJUSTMENTS

To insure trouble-free operation, there are certain adjustments which you must make correctly.

Headspace

Make this adjustment after the gun is completely assembled. The threaded portion of the barrel should be long enough to extend a short way through the barrel extension when screwed in as far as it will go.

1. Retract bolt slightly and pry barrel locking notches to left with point of cartridge until parts no longer return to battery without being forced.

2. Unscrew barrel one notch at a time, until recoiling parts go into battery when you pull bolt back 1 inch and let it go. Pry locking notches to right to unscrew barrel.

3. Unscrew barrel 2 more notches.

4. Check your adjustment with headspace gage.

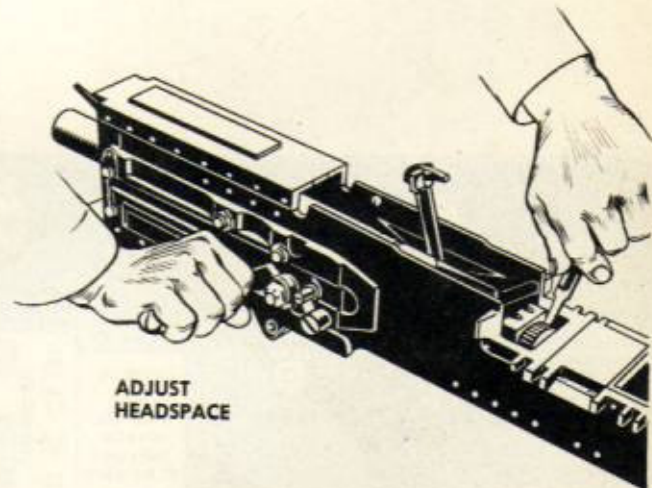

ADJUST HEADSPACE

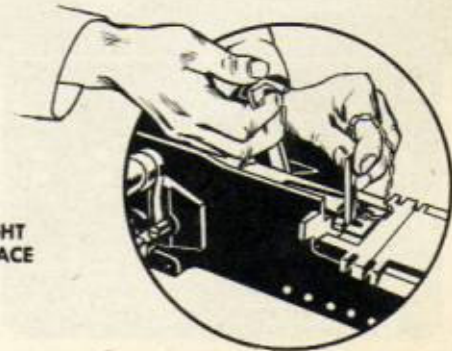

CHECK FOR TIGHT HEADSPACE

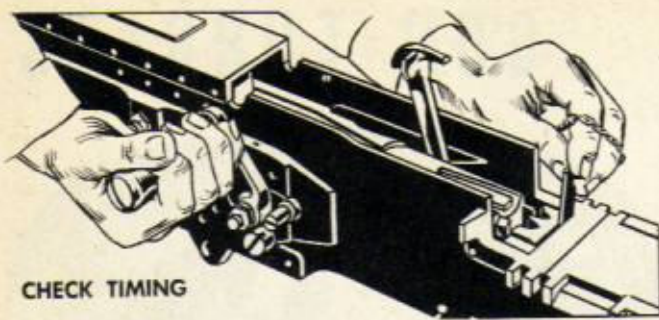

Timing

In automatic firing, the firing pin should release when the parts are a fraction of an inch out of battery position. It is important, therefore, to make adjustments that prevent the gun from firing too early or too late. After you have adjusted and checked the headspace:

1. Cock firing pin by charging gun and letting parts go fully into battery position.

2. Retract recoiling parts slightly and check for **early timing** by inserting **NO FIRE** leaf of timing gage between barrel extension and trunnion block. Let barrel extension close slowly on gage and press trigger. If firing pin releases, firing is too early.

3. Check for **late timing** by following same procedure with **FIRE** leaf of timing gage. If firing pin does **not** release, firing is too late.

If timing is too early or too late, try installing different trigger bars. Remove faulty one, set it onto trigger bar pin, compare it with others, and select one that will depress sear earlier or later, as desired.

Oil Buffer Adjustment

The oil buffer controls the rate of fire and absorbs the recoil of the gun. When you turn oil buffer tube, the size of the restricted openings increases to allow faster recoil, or decreases to allow slower recoil.

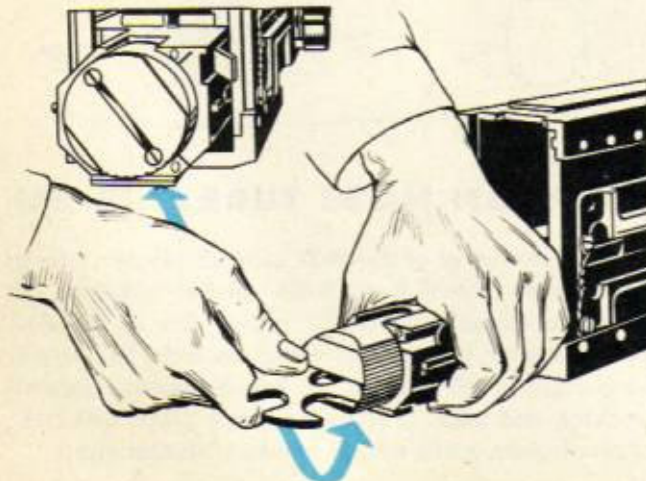

The tube lock protrusion must be in the **third notch from the left** at the bottom of the tube. You remove the oil buffer group to make this adjustment.

PREFLIGHT

1. Before loading, hand-charge gun, testing for smooth operation. This charging consists of pulling grip back and down **hard and fast**. **Do not ride handle forward.**

2. Charge 3 or 4 rounds of **dummy ammunition** through gun to check feeding mechanism. Be sure safety is in **SAFE** position.

3. Clear gun, raising cover to make sure feedway and chamber are empty.

4. Check sights to see that they are not loose or damaged.

5. Check your ammunition for corroded, dented, or bulged cases, short rounds, incorrect linking, and bent or rusty links.

6. When new gun is issued to you, test fire at least 25 rounds before using it on bombing mission.

Use care in the handling of ammunition. Don't drop or stretch belts, or expose them to dirt, grease, or water. Short rounds, caused by rough handling, create a stoppage in nearly all cases. Be particularly careful with armor-piercing ammunition. Break in a gun with at least 100 rounds of ordinary cartridges before using armor-piercing ammunition.

The practice of firing short bursts to warm the guns as the airplane climbs to high altitudes has been discontinued. The changing temperatures cause moisture to collect and freeze.

Parts rust quickly for the guns are only lightly oiled. Therefore, you must inspect the guns daily whether you use them or not. You must wipe them clean and free of all oil before they go out on missions. Keep muzzles covered with tape when not in use, to prevent entrance of dirt and moisture.

In the event of a malfunction or a stoppage of fire, loosen the cover and straighten the belt. Close the cover and charge the gun. If the gun still fails, check for ruptured cartridges. If the belt does not feed, remove the first round, recharge, and fire. To stop a runaway gun, just raise the cover plate. **Caution:** Raise cover plate with hand on opposite side of bolt.

Maintenance, cleaning, and preflight must be thorough and perfect. Your life and the lives of the rest of the crew may depend on the smooth operation of your guns.

REFERENCE: TM 9-225 and TM 9-1225

GUN TURRETS

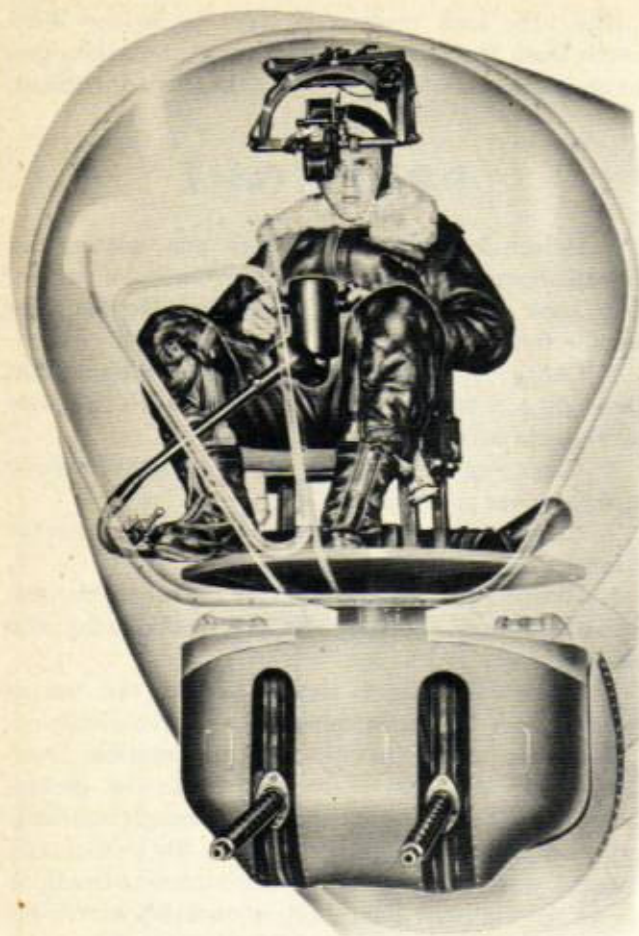

The bombardier is concerned primarily with those gun turrets he is most likely to operate. He is almost always responsible for control of the nose turrets in heavy and very heavy aircraft.

BENDIX CHIN TURRET (B-17)

The chin turret of the B-17 operates electrically by remote control from the bombardier's seat directly above it. It moves 86° to either side in azimuth, 26° above and 46° below horizontal in elevation. It uses the N-8 or N-6A optical gunsight. The bombardier's seat remains stationary; as he turns the gunsight, the guns swing around beneath. The bombardier's control unit, housing the gunsight, pivots out from its stowed position on his right and locks in place in front of him.

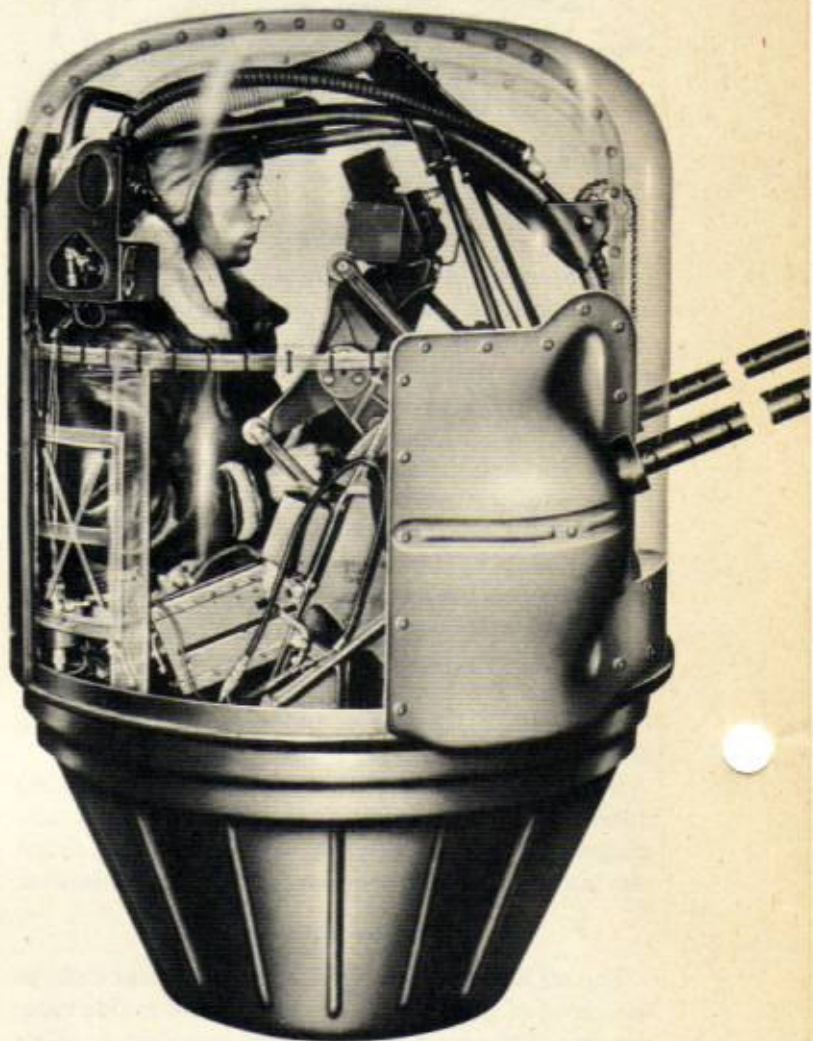

EMERSON NOSE TURRET (B-24)

The nose turret of the B-24 is an all-electric turret which uses the N-8 or N-6A optical gunsight. It moves in azimuth about 75° either side of the airplane's center line, and in elevation from 50° below horizontal to 60° above. It has 2 speeds, normal tracking and high. It contains armor plate, and bulletproof glass plate which moves with the guns.

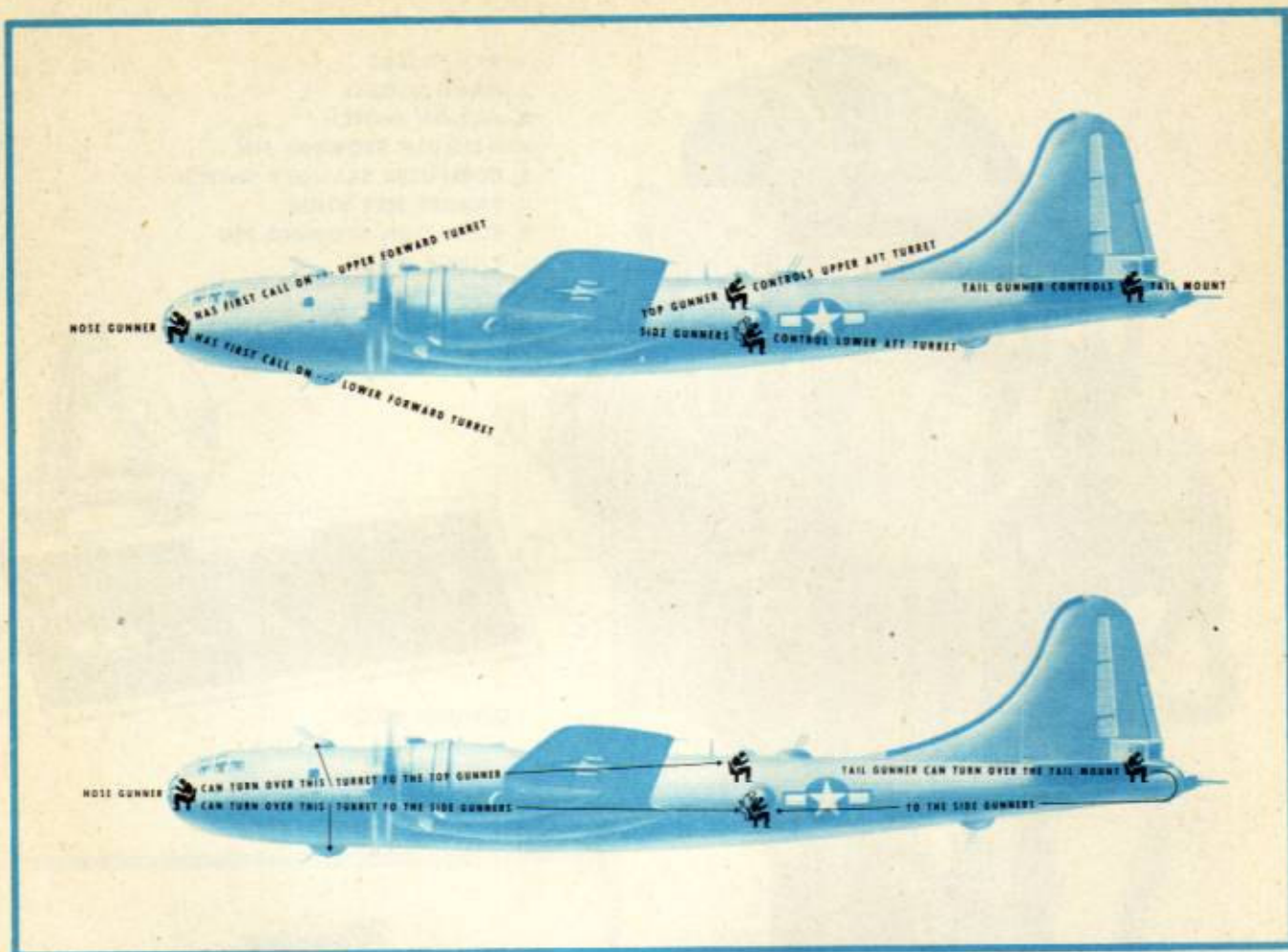

REMOTE CONTROL TURRET SYSTEM (B-29)

The 4 turrets and tail mount of the B-29 all operate by remote control. The gunners sit at **sighting stations** inside the fuselage and manipulate their gunsights. Computers, connected to the sights, automatically figure deflections for any fighter within range.

A system of control transfer enables gunners to take over control of more than one turret for a single gunsight. For every turret there is a gunner who has **first call**. The nose gunner is given first call on the upper and lower forward turrets. This affords him the greatest possible fire power with which to meet a frontal attack.

If he doesn't need the lower turret, he can let one of the side gunners take it over. For instance, he might be using the upper turret to shoot at an enemy coming in high, while at the same time another hostile plane may be coming in low. In such a case, he would give one of the side gunners control of the

lower forward turret. Similarly, he can release control of the upper forward turret to the top gunner.

In the nose sighting station there are 3 units of gunnery equipment that are of concern to you, the bombardier:

1. **Control box** with the necessary switches for operating the turrets and gunsight.
2. **Gunsight** and controlling equipment.
3. **Transfer switches.**

An auxiliary switch on the control box starts the compressor motors that operate the gun chargers. A **computer standby switch** turned to the IN position cuts the computing mechanism into the forward turret circuits.

To operate both forward turrets, turn both transfer switches to IN and press down on the **action switch**. The guns in both turrets then follow your gunsight and fire when you press the trigger.

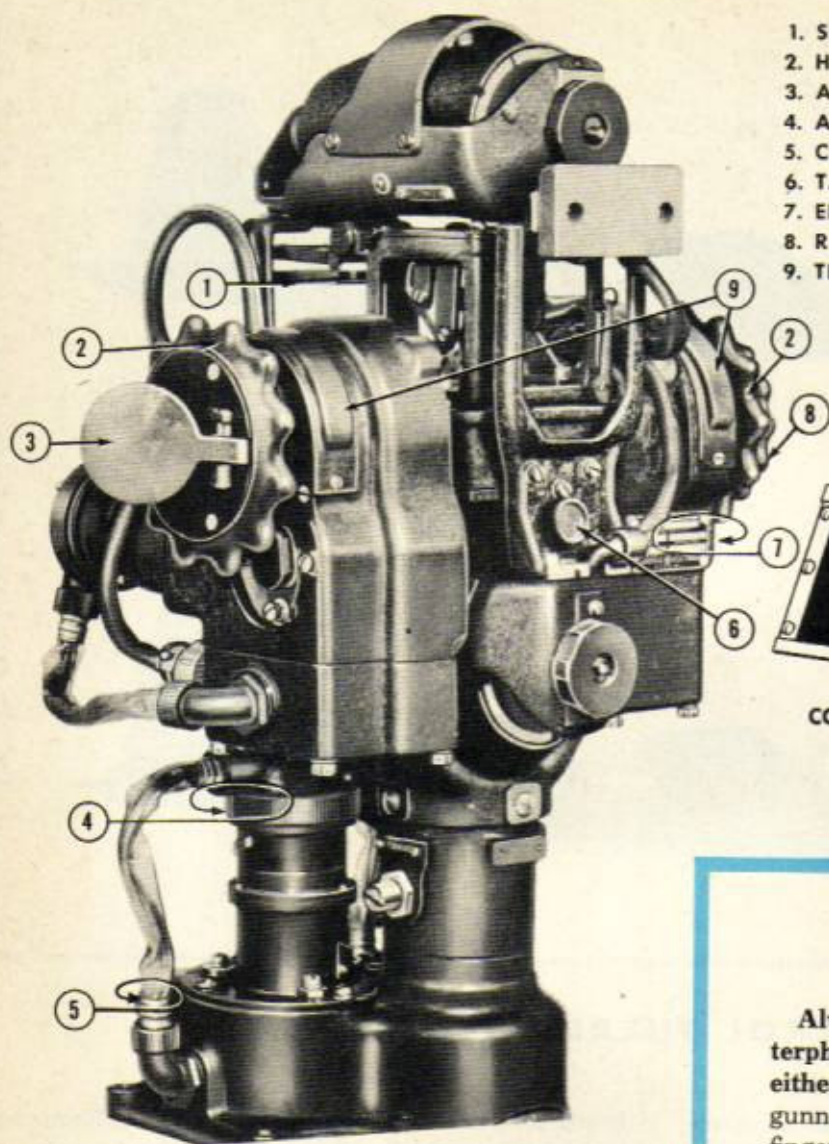

PEDESTAL SIGHT

1. SKY FILTERS
2. HAND WHEELS
3. ACTION SWITCH
4. AZIMUTH STOWING PIN
5. COMPUTER STANDBY SWITCH
6. TARGET SIZE KNOB
7. ELEVATION STOWING PIN
8. RANGE WHEEL
9. TRIGGERS

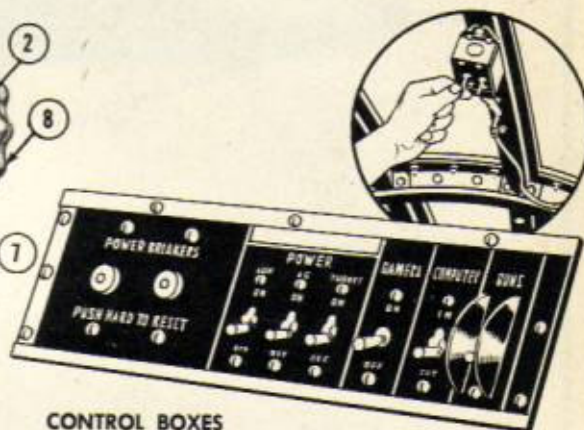

CONTROL BOXES

Warning

Always sound a warning over the interphone before you give up control of either or both turrets. If you don't, the gunner who takes over may have his finger on the trigger and the guns will spray bullets into your own formation as they swing into line with his sight.

To give up control of one turret, use the transfer switches. When the **upper forward turret switch** is OUT, the top gunner has control of the upper turret. When the **lower forward turret switch** is OUT, one of the side gunners takes over the lower turret.

If you take your hand off the action switch, control of both turrets passes automatically to top and side gunners regardless of transfer switch settings.

It is your duty to stow the lower forward turret when it is not in use. Run the turret around so that the guns point aft; then turn off the designated switches. The guns will automatically stow at the correct elevation.

A friction adjustment gives the gun sight just the right touch. You will find there is only one right setting for you. Set the sight so that you can track smoothly. Once you have started tracking, don't change your grip on the hand wheels. Don't jerk your point of aim. Move it smoothly and don't fire until you're on the target.

Cool the guns at every opportunity. If you fire as much as 50 rounds within a short period, look for a chance to move the guns into the slipstream of the airplane—and hold them there.

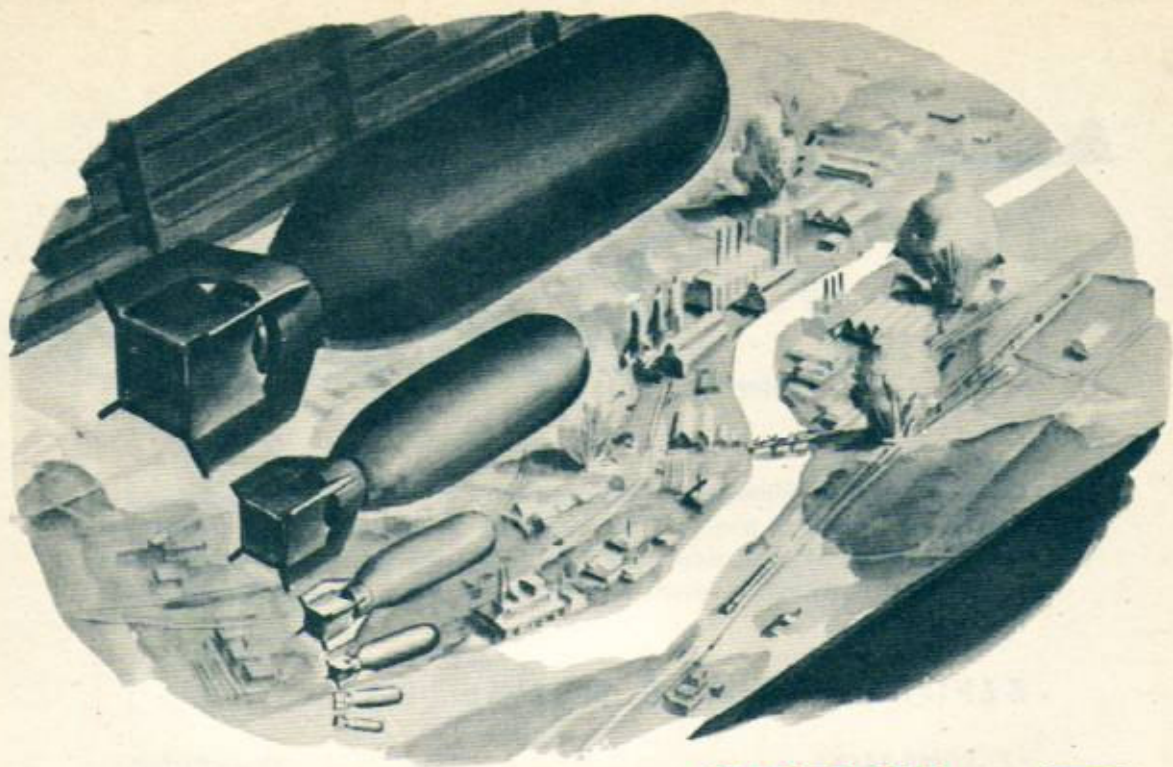

SECTION

8

COMBAT BOMBING...

This is why the airplanes were built. This is why you and your crew and the other crews were trained. In the few tense and crowded moments before bomb release your mind and hands determine whether the efforts and contributions of thousands are to be wasted or made worthwhile. It is then that you earn your reward for extra time spent in studying target identification, bombing techniques at various altitudes, tactical variations. That is when you appreciate the value of flak analysis and are thankful that you know when and how to use evasive action. And there is no time when painstaking study and practice repay you more amply than on those more demanding bombing runs when your target is maneuvering or when you must bomb through overcast.



Bombardier's

The most carefully planned bombing mission can be ruined if the bombardier forgets an essential item of equipment or a vital step of procedure. A thorough check of equipment and steps is his only guarantee that he won't forget. This checklist is a valuable safeguard for his memory. It is not a guide to procedures.

BEFORE LOADING BOMBS

- | | |
|---|-------------|
| 1. BOMB RACKS | PREFLIGHTED |
| 2. BOMBING INTERVALOMETER | PREFLIGHTED |
| 3. SWITCHES IN BOMBARDIER COMPARTMENT | CHECKED |
| 4. SWITCHES IN PILOT COMPARTMENT | CHECKED |
| 5. EMERGENCY RELEASE SYSTEM | CHECKED |
| 6. BOMB BAY SWITCHES | OFF |
| 7. NOSE COMPARTMENT | CLEAR |
| 8. WINDOWS | CLEAN |

BEFORE TAKEOFF

- | | |
|--|--------------|
| 1. PERSONAL EQUIPMENT | COMPLETE |
| 2. BOMBARDIER'S KIT | COMPLETE |
| 3. TARGET FOLDER AND WEATHER DATA | COMPLETE |
| 4. OXYGEN AND MASK | CHECKED |
| 5. PARACHUTE AND LIFE VEST | CHECKED |
| 6. SPARE ELECTRICAL FUZES | COMPLETE |
| 7. BOMBS AND FUZES | CHECKED |
| 8. PINS (IF INACCESSIBLE IN FLIGHT) | PULLED |
| 9. BOMB BAY TANK SAFETY SWITCHES | OFF |
| 10. INTERPHONE SYSTEM | CHECKED |
| 11. BOMBSIGHT | PREFLIGHTED |
| 12. AUTOPILOT | PREFLIGHTED |
| 13. GUNS, TURRETS, AND GUNSIGHTS | PREFLIGHTED |
| 14. CAMERA AND CAMERA INTERVALOMETER | PREFLIGHTED |
| 15. ALTIMETER PRESSURE SCALE AT 29.92 | SET |
| 16. CLOCK | SYNCHRONIZED |
| 17. SWITCHES IN BOMBARDIER COMPARTMENT | OFF |



CHECKLIST

BEFORE IP

1. SWITCHES IN PILOT COMPARTMENT..... CHECKED
2. SWITCHES IN BOMBARDIER COMPARTMENT..... CHECKED
3. ALL BOMBSIGHT SWITCHES..... ON
4. BOMB BAY SWITCHES..... CHECKED
5. PINS PULLED
6. AUTOPILOT ADJUSTED
7. BOMBING ALTITUDE COMPUTED
8. DISC SPEED AND TRAIL IN BOMBSIGHT..... CHECKED
9. AB COMPUTER COMPLETELY SET UP..... CHECKED
10. BOMBING INTERVALOMETER SETTINGS..... CHECKED
11. CAMERA INTERVALOMETER SETTINGS..... CHECKED
12. CAMERA DOORS OPEN

BEFORE BOMBING RUN

1. BOMB BAY DOORS..... OPEN
2. BOMBSIGHT STABILIZER LEVEL
3. PROPER RACK SELECTOR SWITCHES..... ON
4. RELEASE HANDLE (OLD TYPE AIRCRAFT)..... SELECT
5. DRIFT AND DROPPING ANGLE..... PRE-SET

BEFORE LANDING

1. SWITCHES IN BOMBARDIER COMPARTMENT..... OFF
2. BOMBSIGHT POST-FLIGHTED
3. TURRETS AND GUNS..... STOWED
4. GUNS, TURRETS, AND GUNSIGHT SWITCHES..... OFF
5. BOMBING EQUIPMENT MALFUNCTION REPORT..... COMPLETE
6. INTELLIGENCE REPORT COMPLETE

It would be more than tragic to subject a bomber and its crew to the hazards of a mission, to consume irreplaceable time reaching the target, and then to discover that a malfunction prevents the successful accomplishment of that mission. You must avoid any such disastrous cancellation of a mission in the air that might have been prevented on the ground. The need for accurate preflighting of equipment, therefore, is only slightly less obvious than the need for accurate bombing procedure.

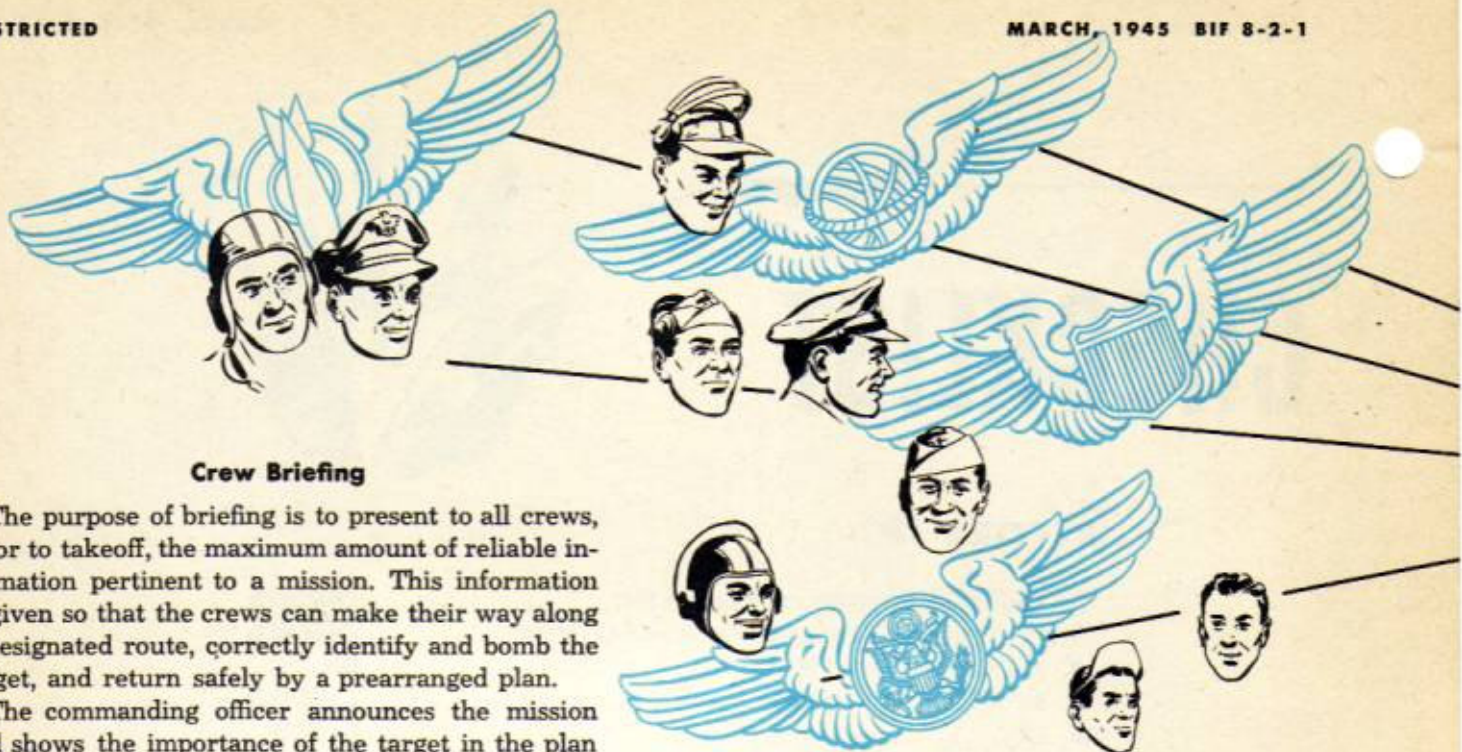

Crew Briefing

The purpose of briefing is to present to all crews, prior to takeoff, the maximum amount of reliable information pertinent to a mission. This information is given so that the crews can make their way along a designated route, correctly identify and bomb the target, and return safely by a prearranged plan.

The commanding officer announces the mission and shows the importance of the target in the plan of battle. The operations officer outlines the route out and return. He designates the units participating and types of formation to be flown, announces full time schedules, and issues landing instructions. He specifies the rendezvous points and IP; axis, altitude, and airspeed of attack; and operational data about the target and aiming point. Information is also provided on bomb loadings, fuzing, fuel, ammunition, supply, special tactics, weather, and communications.

The intelligence officer describes the objective and covers details of the **alternate target** and **target of last resort**. He outlines the known enemy defenses and tactics, including AA batteries, fighter opposition, balloon barrages, dummies, and camouflage. All **friendly information** (convoys, balloon barrages, fighters, restricted areas, ground troops) is given.

The intelligence officer then reminds the crews of what to look for en route. He gives warnings and reminders on procedures in the event of forced landings in enemy territory.

The navigation officer gives a time tick. Then, announcement is made of further special briefing of pilots, bombardiers, navigators, and other crew members.

Special Bombardier Briefings

Special bombardier briefings are held to acquaint the bombardier with those facts about a mission which are particularly applicable to his job. The information is presented in a concise manner and covers all details of the mission from the IP to the target. Each bombardier is given a target folder, bomb-

ing tables, computers, stop watch, and all other available bombing aids. The staff bombardier is usually in charge of these briefings.

The following information is presented:

Target identification. This covers the most prominent check points which aid in identifying the IP, those along the axis of attack, and those which bracket the target. The officer in charge of the briefing uses all available references to point out and emphasize landmarks and recognition features in the target area.

Approximate ETA over IP and distance from IP to target.

Type of sighting. The lead airplane may sight for both course and range, while wing airplanes release upon a signal from the leader or by visual recognition of lead airplane's release. Or the lead airplane may sight for both course and range and wing airplanes for range only. Or airplanes may make individual runs, as is the case in night operations.

Type of release and intervalometer settings.

Plan for evasive action if such action is to be used on the mission.

Altitude and airspeed for bombing run.

Meteorological report. This includes direction and speed of winds at flight level and aloft of the target, surface winds at the target, predicted target temperature and temperatures aloft, mean temperature, and the target pressure altitude.

BRIEFING AND INTERROGATION

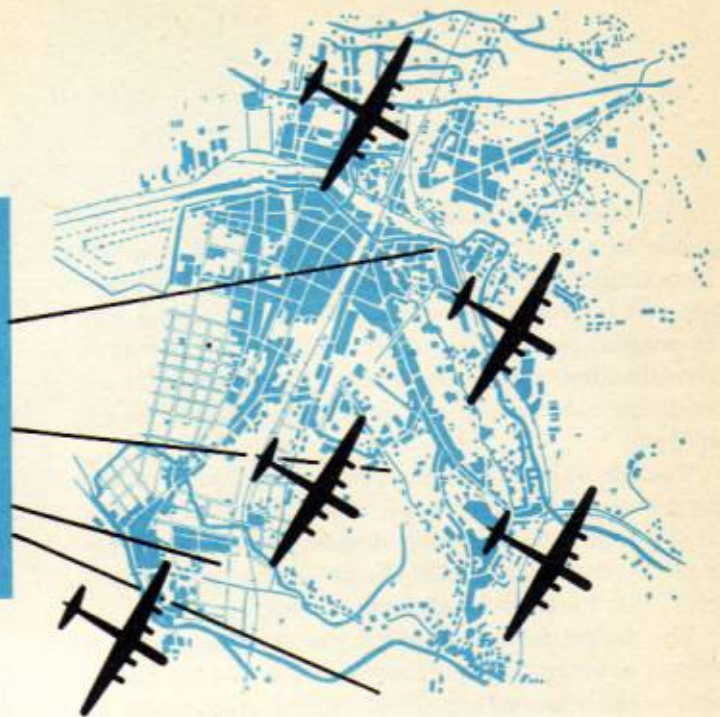

Precomputed data. This includes DS, Trail, Tan Drop \angle , Sight \angle , BA, TAS. These computations are not final but serve as a check on your actual air computations, making any large errors apparent.

Flimsy. This is given to each bombardier participating in the mission. It includes meteorological data, precomputed data, BA, and TAS, and any other facts pertinent to the bombing run.

General information. This includes position of the sun with reference to the axis of attack; moon and tides; camera operation; crew coordination.

Note: A secondary target receives the same attention as the primary target.

INTERROGATION

Interrogation is the process of extracting the maximum amount of reliable information from a crew on its return from a mission. This is necessary for the following reasons:

To give group commanders information about performance of their units, to improve tactical procedure, and correct deficiencies.

To obtain material of tactical nature required by commanding generals of combat wings, air divisions, and bomber commands.

To obtain operational and statistical data required for record and planning of future operations.

To compile public relations information.

Your position in the airplane, as bombardier, allows you the greatest forward visibility of any of the crew. You see more terrain than the pilot, more sky than the waist gunners, more action than the navigator. It is reasonable to assume that you can return with more information.

Most of the time on your way to the target and back is spent studying the ground, observing check points and landmarks, and comparing notes with the navigator. Anything that you see on the terrain that does not correspond with existing maps is an item of vital importance. Any activity of any description, whether it be troop movements, ships sailing in convoys, motor transports or trains moving, is essential for you to note. And when the enemy throws his aerial defenses at you—AA or fighters—you are in a pretty good position to make a quick count and rapid survey. New fighter tactics, armament, and aircraft are facts you must retain for S-2. What kinds of planes? How many? How thick and effective is the anti-aircraft fire?

Future tactics and strategy largely depend on the crews' ability to bring back complete and precise accounts of all that happened.

It boils down simply to keeping your eyes, ears, and mind open.

Get those details. Make your observations clearly. Keep facts straight, and make your report concise and correct.

The success or failure of a bombing mission depends to a great degree on your ability to identify your target. If you have trouble in locating the target you may end up with too short a bombing run or possibly no time for it. The importance of target identification cannot be stressed too much. Use all available information and intelligence aids in target analysis.

The **air objective folder** contains an index of the targets within a given area. It provides descriptions of the region and specific targets, and contains extensive photographs and charts of the various targets. This folder is for ground use only.

The **target folder** provides you with an efficient means of arranging and carrying with you the charts and other material you need to find your target. It is designed to give you instant reference to any of your material.

TARGET FOLDERS

Two types of target folders in common use today are the folder used by the training air forces within the United States and the folder developed in the 8th Air Force. Both folders have definite merit and are somewhat similar in form and content.

The folder used in training is bound in stiff board, covered with black cloth, and measures 9 × 17 inches. It has 5 acetate leaves into which you can insert any material you need. There are also pockets for auxiliary material inside the front and back covers. The acetate sheets between the first and second and the second and third leaves are not stitched to the binding. This permits you to insert a section of chart or map double the width of a single sheet.

The folder used in the European theater consists of 4 sheets of heavy acetate measuring about 14 × 16 inches. It is stitched together in the center and on two of the remaining three sides with a heavy cloth material. This leaves one end of each pair of sheets open to permit insertion of pertinent material. The bombardier can stand this folder on end beside him for ready reference.

When properly prepared for a bombing mission either folder contains essential maps, charts, and photos, arranged in the order in which they are to

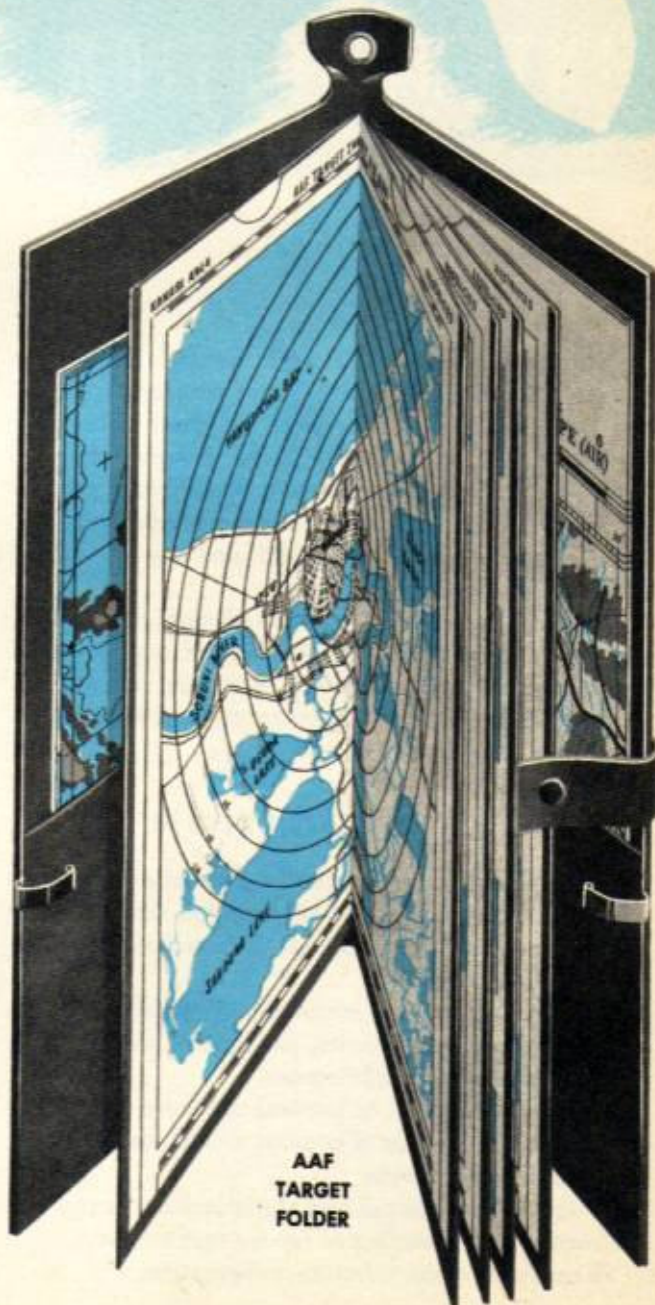

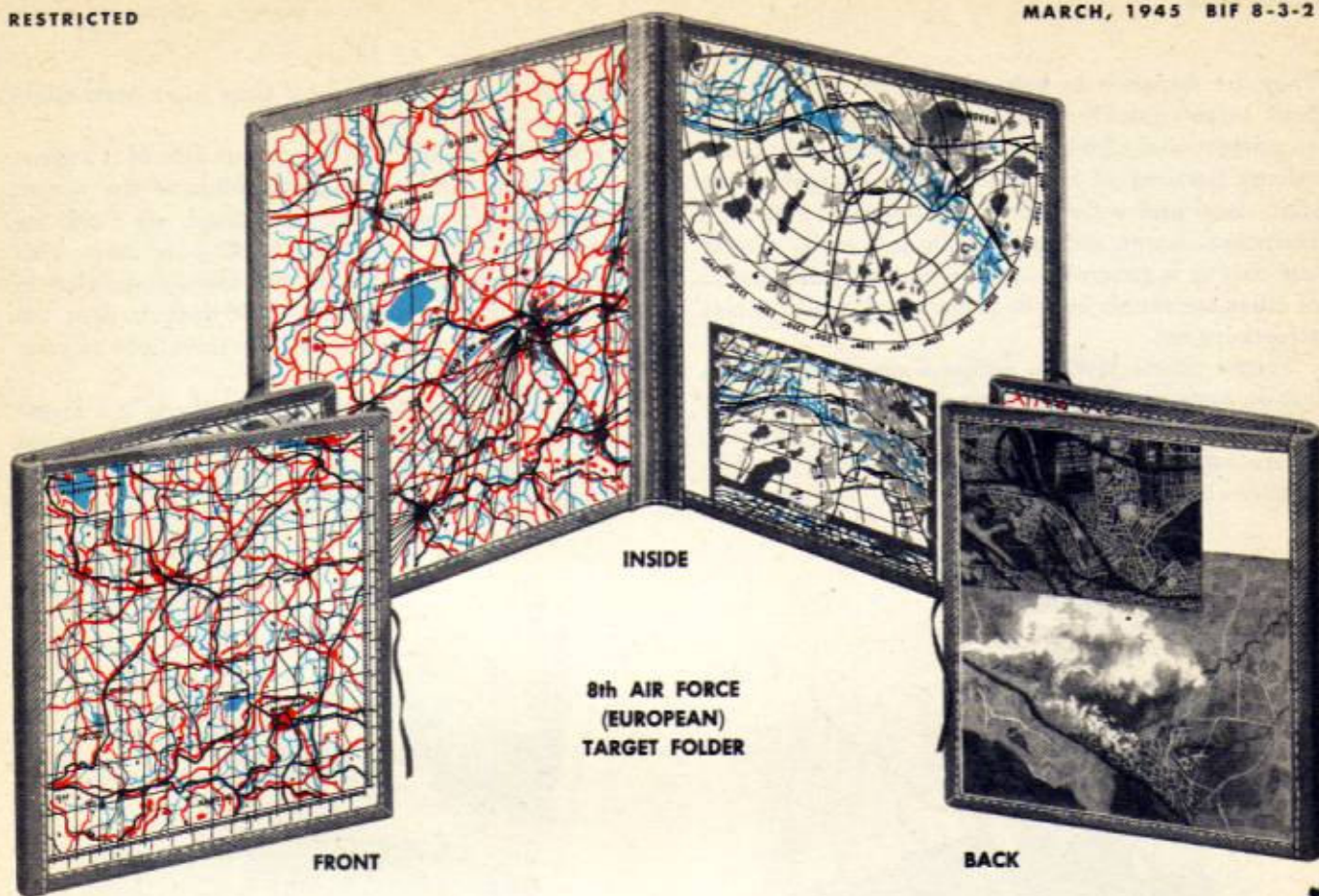

be used. The amount of material your folder contains varies with the type of target, theater of operations, and the chart and photo coverage available. Limit yourself to aids that will help you perform a successful bombing mission. Eliminate useless information. In general, a target folder contains the following essentials:

- Aeronautical chart of target area
- Target charts and perspectives
- Vertical and oblique photographs of target area
- Terrain prints, sketches, or any other auxiliary material pertinent to mission

All materials are supplied to you at briefing, either by your staff bombardier or by your unit intelligence officer.

Aeronautical Charts

Aeronautical charts come in several scales, each type playing its own part in the planning and execution of the mission. **Regional charts**, scaled at 1 inch to 16 nautical miles (1:1,000,000), and **sectional charts**, scaled at 1 inch to 8 nautical miles (1:500,000), are used primarily for navigating to and from the target. Since they cover a considerable area, they are used in plotting the routes to be flown on the

mission. **Approach charts**, scaled at 1 inch to 4 nautical miles (1:250,000), are particularly useful in pinpointing the target because they are on the larger scale. They show railroads, highways, water, land elevations, and most of the prominent terrain features of the immediate target area.

Relief features are represented on sectional and approach charts by colors graduated from light to dark. They range from medium green, denoting elevations up to 1000 feet, through 9 shades of color to dark tan, representing elevations of 9000 feet. Dark brown denotes elevations above 9000 feet. High elevations or peaks are shown by short radiating brown lines, usually with the elevation denoted in figures. Light brown contour lines join points of equal elevation and serve as border lines between the various colors.

Each chart has an explanation of the symbols used. Generally they are standard symbols. However, be sure to check the legend whenever you use a strange chart.

Target Charts and Perspectives

Target charts and perspectives are large scale charts centered around a particular target area.

They are designed to help you locate and identify your target quickly. The usual details that appear on navigational charts are eliminated and only clear, salient features of the area remain. Target charts show land and water patterns, railroads, and main highways. Large cultural (built-up) areas appear but only in a general way. For instance, the shapes of cities are shown but the crisscross designs of their streets are not.

Target charts tend to follow a standard pattern but do vary considerably from theater to theater in color, scale, size, and shape. Charts made in the field, where materials are scarce, may look spotty and unfamiliar to you. They can, however, be extremely

valuable to you, especially if they have been made from recent photo coverage.

The AAF target chart has on one side of it a chart of the area within a 20-mile radius of the target. Concentric circles on this chart mark off 2-mile intervals from the target to the 20-mile limit. This chart includes only details and features you could recognize from a height of 30,000 feet. It does not show relief but merely notes the elevations of various points in the area.

On the reverse side of the sheet there is a larger scale chart of the immediate target area. The radius of this chart is 20,000 feet and the concentric circles represent intervals of 2000 feet.

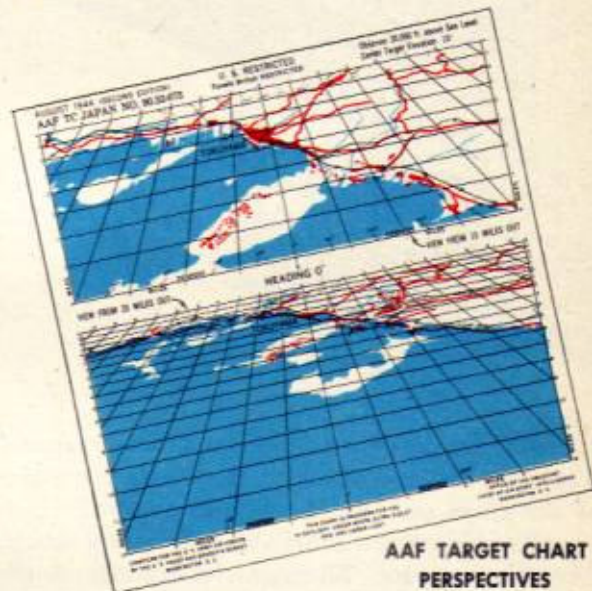
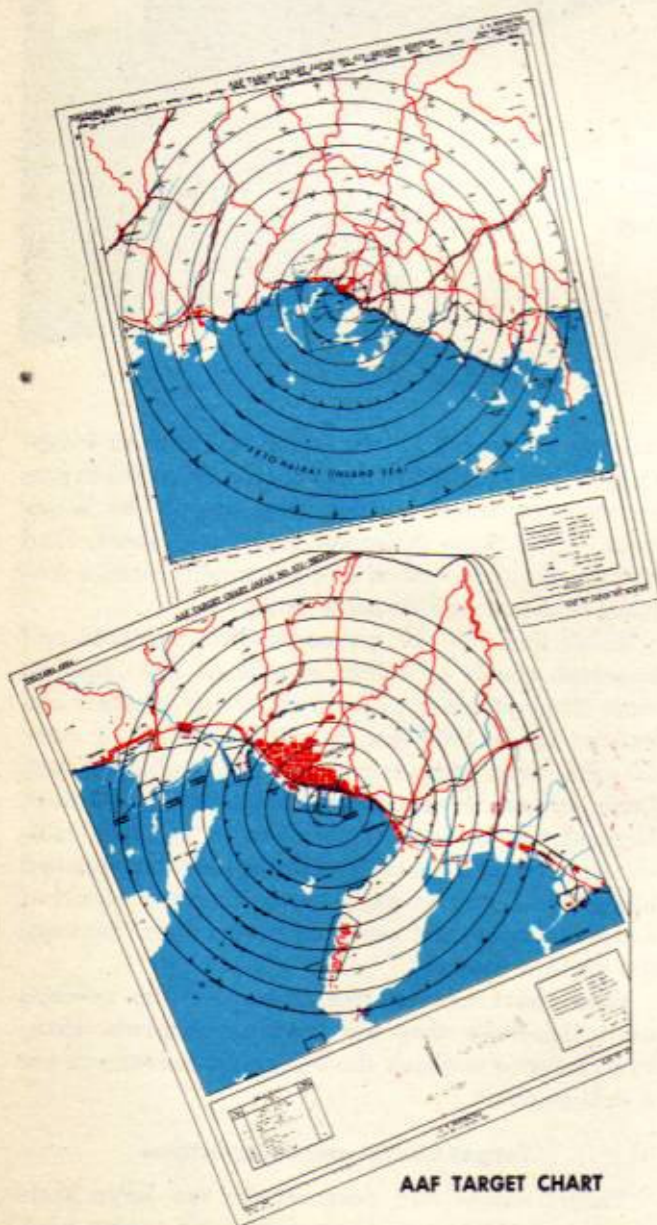

The perspectives used with this chart come on a separate strip. They represent 5 approaches to the target, along different headings. They have been selected because they include good check points and, for various reasons, are the headings most likely to be used for actual approaches. There are two perspective views along each heading. The lower one is primarily for navigating to the target, shown as it appears from 30,000 feet and at a distance of 20 miles. The upper view is for the bombing run. It pictures the target area from 30,000 feet and at a distance of 10 miles.

The circular chart developed in the European theater is fundamentally the same as the AAF target chart. However, it has the vertical chart in the center of the page and the perspectives are printed around it along the various headings they represent. On the center chart, concentric circles at 1-mile intervals run from the target to a distance of 7 miles.

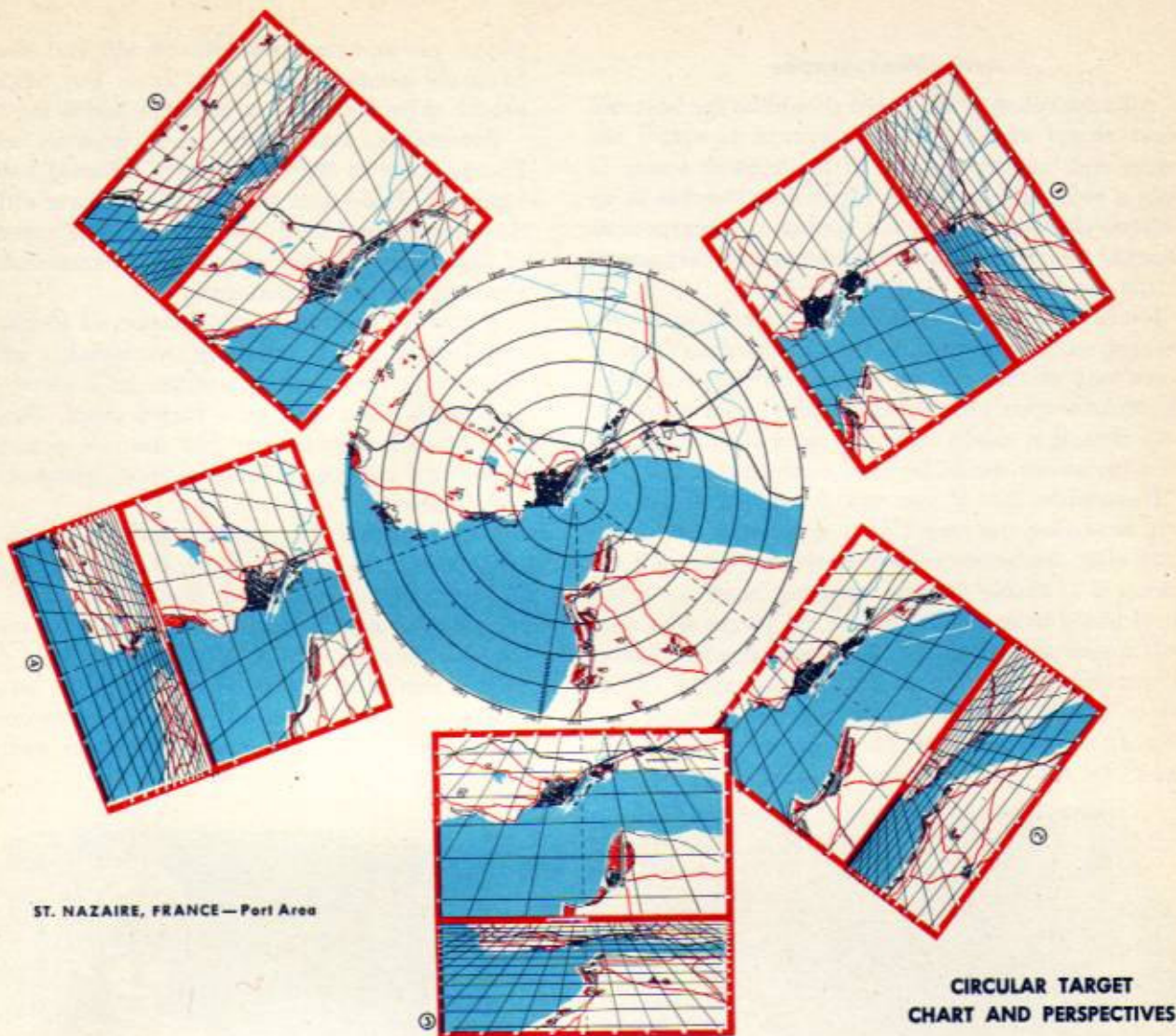

ST. NAZAIRE, FRANCE—Port Area

CIRCULAR TARGET CHART AND PERSPECTIVES

The perspectives for the bombing run on this chart show an area about 3 miles on the near side, about 2 miles to the far side, and about 5 miles to the right and left of the target. The perspectives for navigation show wider areas on all sides of the target.

Standard Legend of Symbols

Here is a legend of symbols usually used on standard target charts and perspectives:

- Airdrome Outlined in black; runways brown. If no runways are shown, "air-drome" is lettered in
- Cliff Brown
- Crater Brown
- Lava flow Brown
- Mudflats and sand.... Brown stipple
- Power lines Typical symbols, brown

- Power plant Black
- Railroad Single black line with:
 - Single track single tics 1/3 mile apart
 - Double track double tics 1/3 mile apart
 - Narrow gage, single track single tics on alternate sides, 1/3 mile apart
- Rice field Blue, with two tics
- Road (primary) Brown line
- Road (secondary) Normally omitted
- Swamp Blue, with four tics
- Target buildings Black; other buildings or built-up areas, gray

Rivers and roads stop short of bridge line to indicate an overpass or bridge. Railroads stop short of bridge line to indicate an underpass. Spot elevations are shown in feet.

Aerial Photographs

All aerial photographs used should be the best and most recent available. A photograph is useful because it is an actual view of the terrain; a map is only a representation of it. Much detail visible in an oblique photograph does not appear on a perspective chart of the same area. Yet the large general pattern is the same in each.

Recent photographs also show alterations in the terrain, such as construction work. This construction work may or may not appear on your target charts, depending upon how recently they were made. If you depended solely on your target chart such terrain variations would be most confusing.

Remember that if you use a vertical photo you will never see the target as it appears in the photo until after the bombs have been released. An oblique photo, if available for the bombing heading, is the ideal photo to use. In it you see the target area as it will appear to you. If more than one target is located in the same area, try to find an old strike attack photo from a previous mission on one of these targets. It will serve as an oblique for an adjacent target if the run is close to that heading. Good oblique



VERTICAL PHOTOGRAPH OF TARGET



OBLIQUE PHOTOGRAPH OF TARGET

photos are an extremely valuable aid. But, don't fail to study photographs taken from the angle and height at which you are going to bomb the target.

Remember that colors and shadows change. Photos made at 30,000 feet have different values of light and shade than those made at lower altitudes. Atmosphere and time of day change the appearance of landscapes. Smoke may haze an area and cloud shadows create new patterns.

A **terrain print** is a combination of a chart and a photograph. It is made by overlaying a photo of the terrain surrounding a target on a chart of approximately the scale of a target chart. The chart is quite fully detailed so that there is a minimum of contrast between it and the photo sections of the terrain print.

AAF city plans are charts drawn on an especially large scale. They show clearly the sizes and shapes of the target installations themselves. City plans are usually used only in mission planning and target identification.

Sand models of the target area give you an excellent idea of how it looks. They help you to visualize the topography and provide a realistic picture of the target.



Successful identification of your target from the air depends in great measure on the careful planning and analysis which must precede every bombing mission. Any material about the target, the target area, or the country as a whole is useful to you. Remember that all charts used may not be standard. Don't let an unfamiliar chart confuse you.

You have a great deal of work to do in your analysis, so organize an orderly procedure. Plan your analysis to include:

Definite mental picture of the target itself as it appears from the air.

Group of easily identified check points near IP, along axis of attack, and around target area.

Clear grasp of the nature of the whole surrounding area with its important features.

Remember that all navigational charts are essentially the same. They are designed to show the geographical characteristics of the area over which you are flying. Likewise, all target charts are essentially the same. They are designed to give you a clear, simplified picture of the target area.

Spend some time on target identification study during off flying days. Your intelligence officer is always glad to cooperate and provide the necessary material. He will suggest probable targets of the future. A little extra time devoted to target identification will make your job of analysis much easier at some future date.

Check Points

The main purpose of your analysis, aside from giving you a general understanding of the terrain, is to provide you with the best possible check points for all stages of your mission.

Here are a few important rules to guide you in selecting check points:

Make use of the best check points the region affords. Ask your navigator for assistance in making your selection.

Don't rely on any one type. In Europe cultural check points are plentiful. In most parts of the Far East you must depend on relief or distinct land and water combinations.

Pick features which are distinct from the surrounding area and are not duplicated nearby.

Consider whether or not they will be easy to see when you are at your bombing altitude. From high altitudes, many topographical features are not distinguishable.

Look for characteristic shapes in both natural and man-made features. Storage tanks, for example, are round and easily recognized.

Look for combinations of features. A railroad alongside storage tanks helps identify them as those you are looking for.

Look for patterns or designs. If storage tanks are at the intersection of a railroad and a river, and you know there is no other such intersection in the area, you can be certain of them.

After determining the pattern of check points in the target area, note the position of the target in the pattern. This is important. Check the position of the target in relation to each check point of the pattern, as well as to the pattern as a whole.

Select few check points. Be sure they are the best available in the area, but keep them to a minimum.

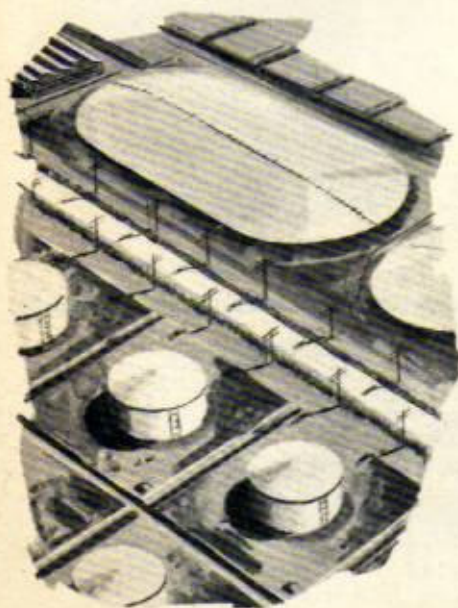

Look for characteristic shapes.

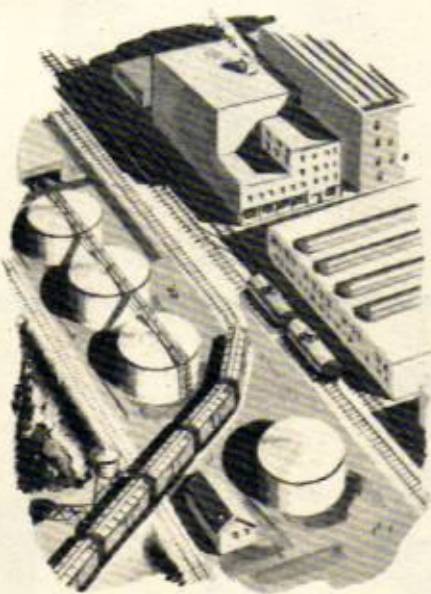

Look for combinations of features.

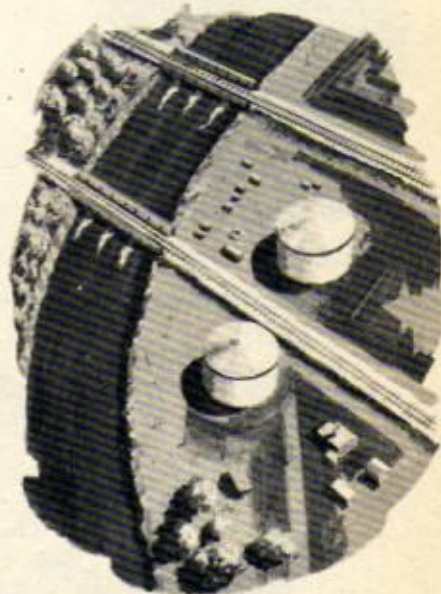

Look for patterns or designs.

These are some of the landmarks which make good check points:

Populated areas: Large cities with definite shapes. Small cities with some outstanding check point, such as a river, lake, or structure to identify them. Speedways, railroad yards, and underpasses. Race tracks, stadiums, and grain elevators.

Open areas: Any town or village with identifying structures or terrain features adjacent. Paved highways, large railroads, race tracks, fair grounds, factories, bridges, and underpasses. Lakes, rivers, coastlines, mountains, ridges, when distinctive.

Forested areas: Transmission lines and railroad rights-of-way. Roads and highways. Forest lookout

towers. Farms, rivers, lakes, clearings, open valleys.

Mountainous areas: Prominent peaks, cuts and passes, gorges. General profile of ranges. Transmission lines, railroads, large bridges over gorges, highways, lookout stations. Tunnel openings and mines. Clearings and grass valleys.

Coastal areas: Unusual coastline features. Lighthouses, marker buoys, towns and cities, structures.

Seasonal changes: Unusually shaped wooded areas in winter. Dry river beds, if they contrast with surrounding terrain. Dry lakes.

In general, select for check points abrupt changes in physical appearance, such as mountains to flat areas or forests to farms.



POPULATED AREAS



OPEN AREAS

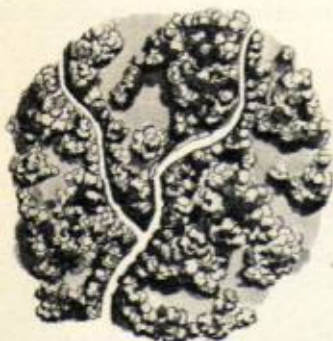

FORESTED AREAS



MOUNTAINOUS AREAS



COASTAL AREAS



SEASONAL CHANGES



ABRUPT CHANGES



TARGET IDENTIFICATION

Checklist

When you have studied all your material and are ready to select your check points, use a checklist adapted to the theater of operations and the type of mission. The following checklist is general, but you can adapt it to your particular circumstances:

Target Area and Target

- What is the general shape of the target?
- What is its most outstanding visible feature?
- How does it appear from different headings?
- What combination of features encloses or boxes the target?
- What lies in front of the target to provide the best check points if the target is obscured?
- What secondary check points can you use if your main ones are obscured?
- Will the shadows on the photographs be the same when you are over the target? At what time of day were they taken?

Terrain Identification

Since terrain features provide your check points, you must also check the completeness of your information about those you expect to encounter.

Will you encounter tidal water, and if so, what will be the effect of high or low tide on the terrain?

What are the distinguishing characteristics of the rivers in the region?

Can a canal be mistaken for a railroad? Is it likely to be camouflaged in part with netting?

What lakes or reservoirs are there, and what distinguishing shapes set them off from others in the region?

Do railroads funnel in toward target? If not, what other patterns do they make or form parts of?

What highways are near the target and what identifying features, such as clover-leaf overpasses or underpasses, do they have?

Are there any bridges sufficiently prominent to help identify the target?

Is the built-up area around the target dense, and if so, what characteristic design do its streets and squares form?

Is the built-up area sparsely settled?

If there is a smoke screen, can you tell where your target is from check points around the edges of the area?

Are there distinctively shaped patches of woods which cannot be confused with others nearby?

Have woods been confirmed by recent photos, or may the enemy have cut them, thus changing their shape?

What kinds of trees compose the woods—scrub, evergreen, deciduous?

Are there any city parks or other wooded sections in the built-up areas?

Are there any notable color differences in the terrain, such as the scars of road building?

Is there any construction of buildings, canals, railroads?

Are there such features as steep cliffs, which may cast shadows visible from your altitude?

Summary

What are the 5 main check points on any course, lying between 30 miles and 7 miles from the target?

What are the 5 main check points on any course, lying between 7 miles and 1 mile from the target?

What are the 5 main check points on any course, within 1 mile of the target?

In case the target is obscured and you have to use offset bombing, what points on the near side of the target can you use to synchronize on? How will you check on whether or not you are on course?

You must have a clear-cut impression of what you intend to look for in the target area from the air.

PREPARING TARGET FOLDER

When you have completed your analysis of all the available target material pertinent to your mission, select what will be most useful to you during the actual flight. Obviously this will be the clearest and most recent coverage of the route just prior to the IP and the route into the target area. Don't burden yourself with excess material. Try to keep it to a minimum, but select the best.

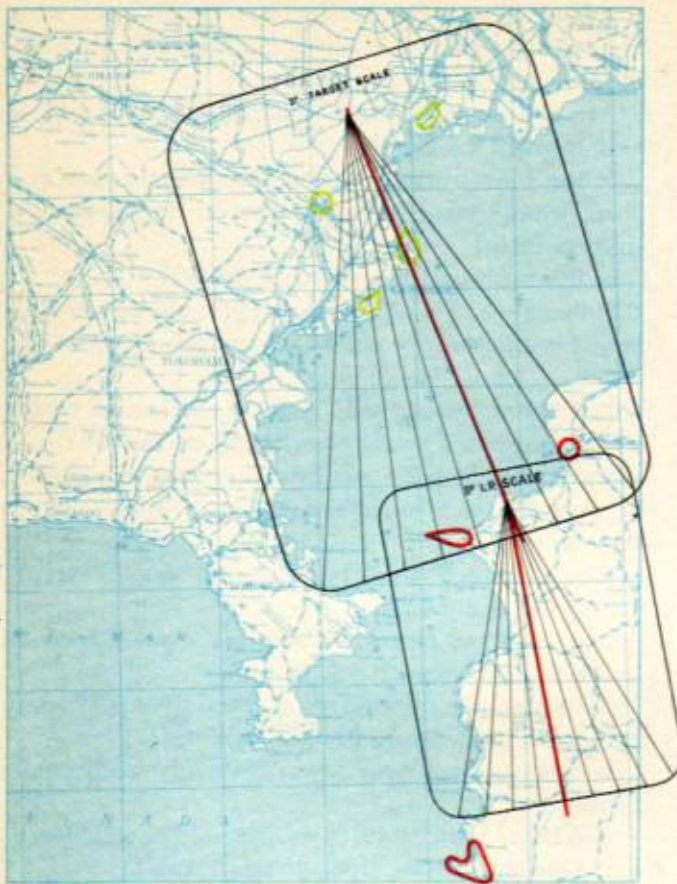

Plot course and mark check points on your chart.

See that all your charts are clearly marked. A chart is meant to be used, marked on, and improved. Draw your course to the IP and your course from the IP to the target and circle your check points. Use pencils of different colors to differentiate between check points. It is advisable to overlay the 5° funnel (BIF 8-10-3) on your chart or to draw in some similar aid for the bombing approach.

All of the check points you find by study probably appear on your target charts. If you have found additional ones or have gathered other information that you may want quickly during flight, mark your chart accordingly.

Briefing provides you with other essential information. Camouflage, for instance, is not shown on navigational or target charts. If you have been told of camouflaged installations, mark them down.

Remember that a mission may or may not be planned to approach on one of the several headings for which you have perspectives. However, with 5 or 6 perspectives, each looking at the target from a different angle, you can easily interpolate a useful rough view for your actual approach.

When you have selected and marked the material you want, insert it in the target folder in the order in which you intend to use it. First, you should have an approach chart on which your route from the IP to target is outlined. Then come your target charts and perspectives and large scale charts. Insert photographs where they are most useful. You can put oblique photos, for instance, in the same leaf with the corresponding perspectives. Or, if you prefer, you can arrange all photographs in subsequent leaves. The important thing is to have an arrangement of material which lets you read your charts and photos quickly and without confusion.

If your target charts and perspectives are on separate sheets, put them into your target folder in such a way that you look quickly from one to the other. If they are on a single sheet, fold it so that only the sections which pertain to your selected bombing approach show.

Insert all maps and photographs into the leaves in such a way that you will read them **in the same direction**, the line of flight always being from bottom to top. **This is important.**

USING THE TARGET FOLDER

If you have prepared yourself, your charts, and your folder correctly, you begin your mission with a background of detailed information. In addition you have a clear, simplified picture of the general pattern and important features of your target area. When you are in the air, dismiss from your mind all the small details of the chart. Concentrate on the prominent features you have chosen to guide you.

While it is far better to have four or five salient points in mind than a hazy idea of twenty, remember that **any** check point is of value to you when the main ones are hidden or you find yourself off course.

Remember that the ground doesn't look exactly like the photographs you study. From your position in the airplane you probably see many times the area covered by any one photograph. The photo does not show you colors, although these appear on the terrain. It may have been taken from a heading, altitude, or angle which does not correspond to the actual flight of the airplane.

Don't be confused by these seeming discrepancies between study and practice. Your check points, or their alternatives, are there. By constant practice and observation whenever you are in flight you can train your eyes to recognize landmarks on the ground from all altitudes and angles.

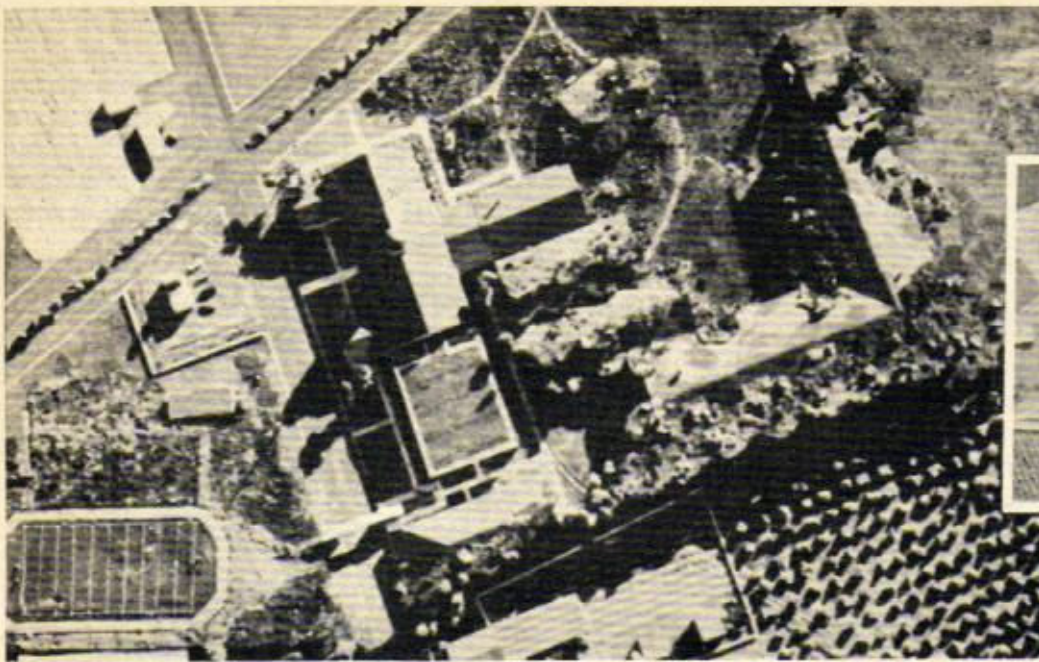

CAMOUFLAGE

It isn't easy to recognize a three-dimensional target in color when you have been briefed on it with black and white photographs. It is harder still to recognize it when the enemy has cleverly altered or even totally changed its appearance and perhaps that of the whole target area. Don't underestimate his ingenuity. It can easily deceive you and make your mission useless.

You must have a keen sense of color, pattern, scale, and, most important, of texture to detect the

enemy's camouflage visually. The only way to develop this natural asset is to practice observing constantly while you are on flights.

Any ground pattern which doesn't agree with your memory of the pattern recorded on the latest reconnaissance photographs should tell you instantly that something has been altered or possibly concealed.

It is then that your own ingenuity in selecting check points pays handsome returns. If you have chosen check points which are difficult or impossible for the enemy to conceal or change in appearance, you still can find the target with comparative ease.



This is your target.



Can you recognize it here?

The cleverest camoufleur can't hide or disguise mountains, hills, rivers, and forests. Neither can he do much about bridges, irrigation ditches, canals, large gas tanks, railway yards, parks. However, he can make enough changes in nearby portions of the landscape to confuse you considerably, if you are not prepared for his tricks. And on a precision bombing mission it takes only a little confusion to cause a wide miss.

Typical Tricks

Fortunately, the devious ways of the camoufleur are just about the same the world over. Here are some typical tricks:

Changing the apparent shape of industrial plants so that they look like schools or farm buildings.

Hiding buildings under nettings garnished with false trees so that they resemble hills.

Altering the appearance of driveways, traffic lanes, railroad spurs, by painting them to match the adjacent ground.

Altering the apparent direction and pattern of driveways, traffic lanes, railroad spurs, by painting the adjacent ground to look like them.

Erecting flat tops over buildings with distinctive shapes or unusual roof designs, and painting tennis courts, pools, or other innocuous objects on top.

Using bright color to focus attention on a relatively valueless structure, sometimes false, and to divert suspicion from vital adjacent buildings under dull-covered netting.

Building false structures resembling farm houses, residences, barns, and surrounding them with phony orchards; plowing fields in areas where farming normally isn't done.

How to Detect Camouflage

Traffic produces a telltale shine on a painted surface, no matter how its true nature has been disguised. This is particularly noticeable on airport runways and highways adjacent or leading to factories.

Structures, however altered in appearance, still have about the same height. When viewed from the low oblique or when the sunlight is behind them, they are readily recognizable.

Flat tops require netting stretched out some distance to the side, to provide room to plant false trees and hide geometric shadows. These false structures create suspicious-looking mounds, easily detected against the sun from the low oblique.

When a fairly large area of netting is involved, it is difficult to match color and texture with those of the surrounding countryside. An eye trained in ob-

servation from the air can quickly spot false notes in both color and texture.

Openings have to be left in netting so that normal traffic to and from industrial buildings can continue. These openings leave distinct shadows where you know there shouldn't be any. Always be suspicious of shadows in odd places and the lack of shadow where you know it should be.

Fortunately for you, most of the world's factories were built before the war, with little or no consideration given to the thought that some day it might be necessary to protect their sprawling characteristics from an airman's view. Consequently, there is almost always some building or group of buildings which defies complete concealment because of the nature of operations within. High smoke stacks, for instance, are nearly impossible to hide.

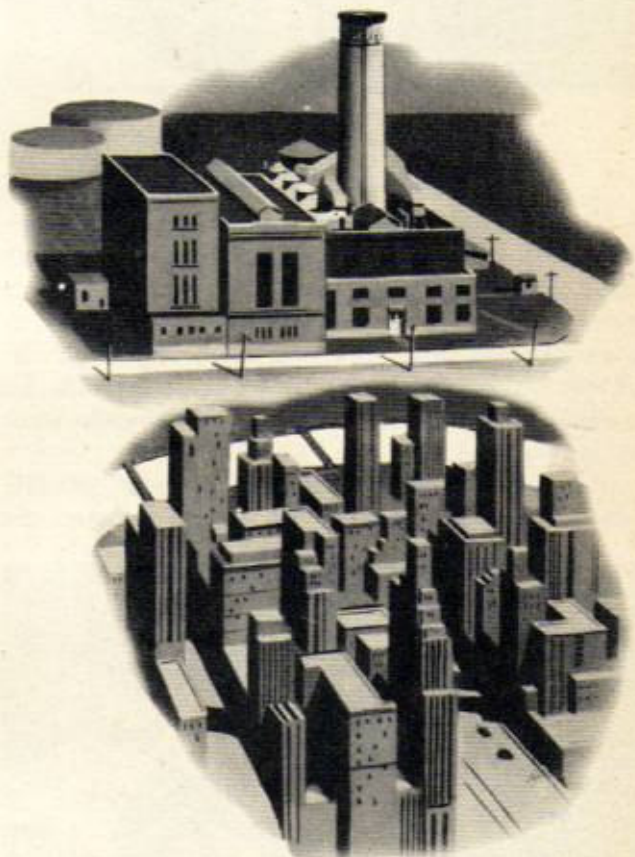

Structures above skyline are impossible to camouflage.

The enemy may try to mislead you by setting up dummy targets and reference points. Don't be thrown off the track by finding a reference point where it doesn't belong. Always check it carefully against the others you expect to find nearby.

Be suspicious of any obvious reference point which has not been camouflaged.

TRAIN BOMBING



Train bombing gives you the best possible chance of partially or totally destroying your target. It consists of dropping an evenly spaced series of bombs across the target. The intervalometer controls the spacing of bombs in the train.

In releasing a train of bombs, you should release the first bomb to hit short of the target a distance equal to half the length of the train. Thus you attempt to place the middle bomb of the train on the target's center. This makes it most likely that at least one or more bombs will hit the target in range.

To find the distance in mils that your first bomb must hit short of the target:

1. Find length of train of bombs by multiplying number of bombs minus 1 by interval in feet between successive bombs.

2. Find distance short, in feet, by dividing length of train by 2.

3. Convert the resulting distance in feet to distance in mils by multiplying it by 1000/BA.

The following equation summarizes these calculations:

$$\text{Mils short} = \frac{500 (\text{Number of bombs} - 1) \times \text{Interval in feet}}{\text{Bombing Altitude}}$$

You can place the first bomb of your train the proper distance short of the target by decreasing trail, decreasing DS, or by selecting an aiming point the proper distance short of the target.

You can easily decrease the trail setting but, unless your bombsight has a trail spotting device, this may result in an appreciable error in crosstrail.

To find the proper amount to decrease DS:

1. Determine approximate mil value of 1 rpm decrease in DS. To find it, double the GS you expect to have over the target and divide that figure by 100.

2. Determine number of rpm to decrease DS. You do this by dividing mil value per rpm into number of mils needed to cause first bomb to hit half train length short of target.

If a definite object, such as a road or building, is on your axis of attack and the proper distance short of the center of your target, you can use it as the aiming point. This will place the mean point of im-

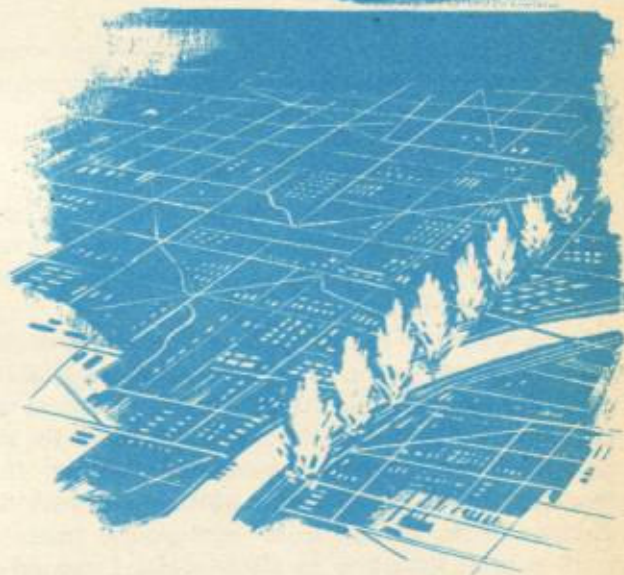

pact (MPI) of your train of bombs on the target's center without requiring you to decrease trail or DS.

When using the intervalometer:

1. Place train-select switch at TRAIN at least 1 minute prior to release.

2. Set counter knob pointer at number of bombs desired in train. If releasing in train all the bombs on the racks, set pointer at a number greater than your entire load to make sure you drop them all.

3. Set GS you expect to have over target opposite desired bomb spacing.

When your indices meet, check to see if intervalometer is working properly. If a malfunction occurs and all bombs have not been released, salvo remainder or change train-select switch to SELECT and toggle them as fast as possible.

FLAK ANALYSIS AND EVASIVE ACTION



CONTINUOUSLY POINTED FIRE

To counteract the effect of AA fire, you must know the three types which you normally encounter over a target.

Continuously Pointed Fire

This is the most accurate and therefore the most dangerous type of AA fire. Enemy flak gunners use it whenever they can track you and whenever your course is predictable.

It takes from 10 to 20 seconds of tracking to enable the fire control instruments to compute the lead for the first rounds and pass this initial firing data to the guns. After that, it takes from 5 to 30 seconds for the first bursts to reach your predicted position. This time of flight varies with your altitude and with the distance of the battery from your ground track. **A good rule of thumb** is to allow about 1 second of flight for the shell for each 1000 feet of altitude.

Once the computation of firing data has begun, the enemy guns are continuously pointed; that is, they are given a continuous lead based on your speed and direction of flight. Successive bursts then move along with the airplane or formation. One battery produces a ragged line of bursts; several batteries produce a rough cylinder of bursts.

Predicted Concentration Fire

This type of fire is delivered by several batteries operating under central control. Ordinarily it is not so effective as continuously pointed fire. But if the airplanes are free to take evasive action and are not doing so, all batteries within range may open fire with a predicted concentration. This is done to produce the maximum possible number of bursts in the formation before evasive action begins. They then switch to continuously pointed fire, to do as



PREDICTED CONCENTRATION FIRE

much damage as possible before the evasive action becomes effective. These tactics are frequently used at coast crossing or by itinerant or route flak, encountered on the way to or from the target.

If clouds prevent optical tracking, and countermeasures prevent accurate radar tracking, predicted concentrations or moving barrages may still be fired effectively if the formation can be followed even roughly and holds a predictable course for 90 seconds or more. If the formation holds its course for 150 seconds or more, the same guns can produce two concentrations.

Barrage Fire

This is the flak gunner's last resort. It is the least accurate type of flak and therefore the one which he

least likes to use. It is expensive, too, because it expends a great amount of ammunition for a small return. When fire control equipment is missing, or if radar is completely jammed and optical tracking is impossible because of poor visibility, the flak gunners can no longer fire directly at your formation. But it is still possible for them to produce bursts where your formation may go or may be forced to go in order to bomb the objective those guns are defending. If the enemy gunners have correctly estimated your altitude and guessed the general direction of attack, they can determine roughly your approximate point of bomb release. Then the enemy can fire all his available flak guns at a point between you and your point of bomb release, in order to hang a curtain of flak you must fly through.

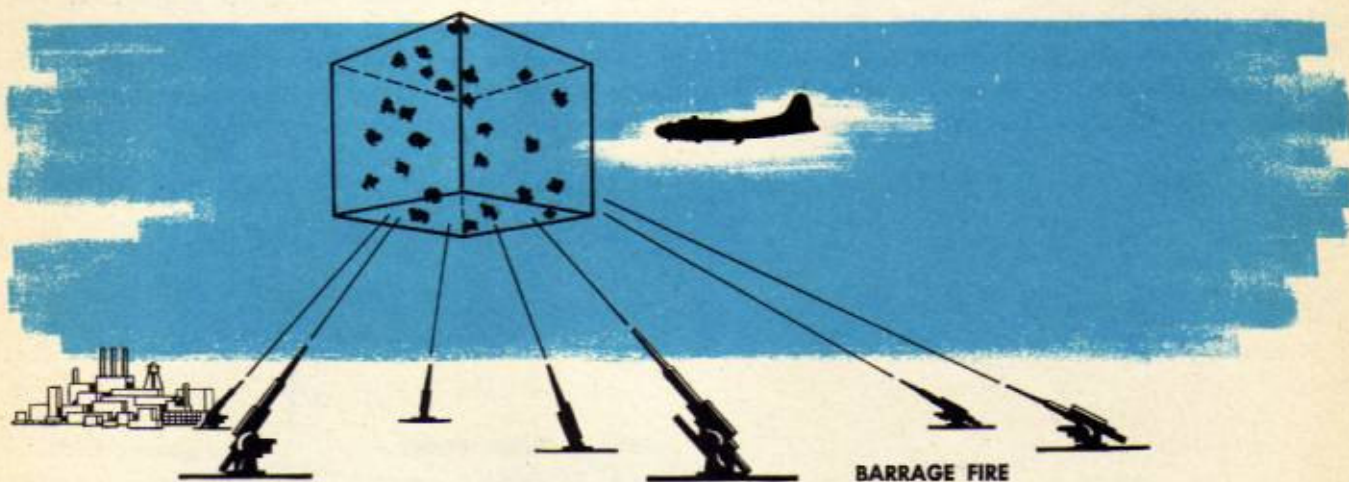

Flak Analysis

Flak analysis consists of determining the areas in the sky over a target where the heaviest concentration of AA fire will be encountered. It is done before a bombing mission by a trained flak analysis officer, who makes his analysis with a flak computer and a flak clock. The flak clock is a chart of known enemy gun positions protecting a specific target.

In using the flak computer, the flak analysis officer considers: the maximum range of fire for each battery of guns; all possible headings for the bombing run; the total time which the bombers will spend in straight and level flight from the start of the bombing run until a few seconds after bomb release.

The flak analysis officer makes computations for each enemy battery individually and for each 30° segment around the face of the flak clock. He figures the probabilities for every gun's fire power. He takes

into consideration both the course to the target and the course away from it.

When his calculations are complete, he knows the relative intensity of flak which may be expected on each possible heading. On that basis, he gives each heading a priority value.

Since his analysis considers only the vulnerability of each heading to AA fire, the flak analysis officer's findings are not conclusive in determining which heading the bombers will take on their bombing run. In planning a bombing mission all factors contributing to its success must be studied to determine the best axis of attack. Other factors which affect the bombing approach and bombing run, such as direction and speed of the wind, may be such that a 3rd instead of a 1st priority heading will be used despite the heavier flak to be expected. However, flak analysis has proven its worth by saving crews, airplanes, and equipment.

Evasive Action

There can be no established policy regarding the length of time airplanes should stay in straight and level flight over heavily defended areas or how much evasive action to take to avoid AA fire.

A certain percentage of airplanes on every bombing mission is hit by AA fire, but only rarely has a single AA burst destroyed a heavy bomber. Battle damage, however, may cause an airplane to lose its position in formation, often with disastrous results to it from enemy fighters.

Your evasive action must be planned for the area between the IP and the target. It must be planned before takeoff, so that all men participating in the bombing mission will know what is to take place and at what time.

To evade AA fire an airplane can change course, altitude, or both. A change of airspeed is not conducive to maintaining good defensive formations. If in changing altitude you assume a constant glide, AA directors can compute your future position and

fire accurately. You must vary your rate of descent. To be most effective, deliberate losses in altitude should vary from 500 to 2000 ft/min. That is practicable with a small formation. It is almost impossible for a large formation to attempt and still maintain a semblance of good formation.

The success of AA fire is based upon predictions. Accordingly, if you change course, the accuracy of AA is largely decreased. Changes of course should always be such that flak gunners cannot determine a mean line of flight. But always remember that extensive evasive action only prolongs your time over the target area and increases the possibility of bombing errors.

All evasive turns of the longest duration should favor the upwind direction and usually you should make 2 turns upwind to prevent S-ing. Plan to bring airplane and formation out at the proper time and on the proper heading for your bombing run.

When you fly a straight leg, alter course a sufficient time before the shell reaches your altitude to have your airplane off the original line of flight when

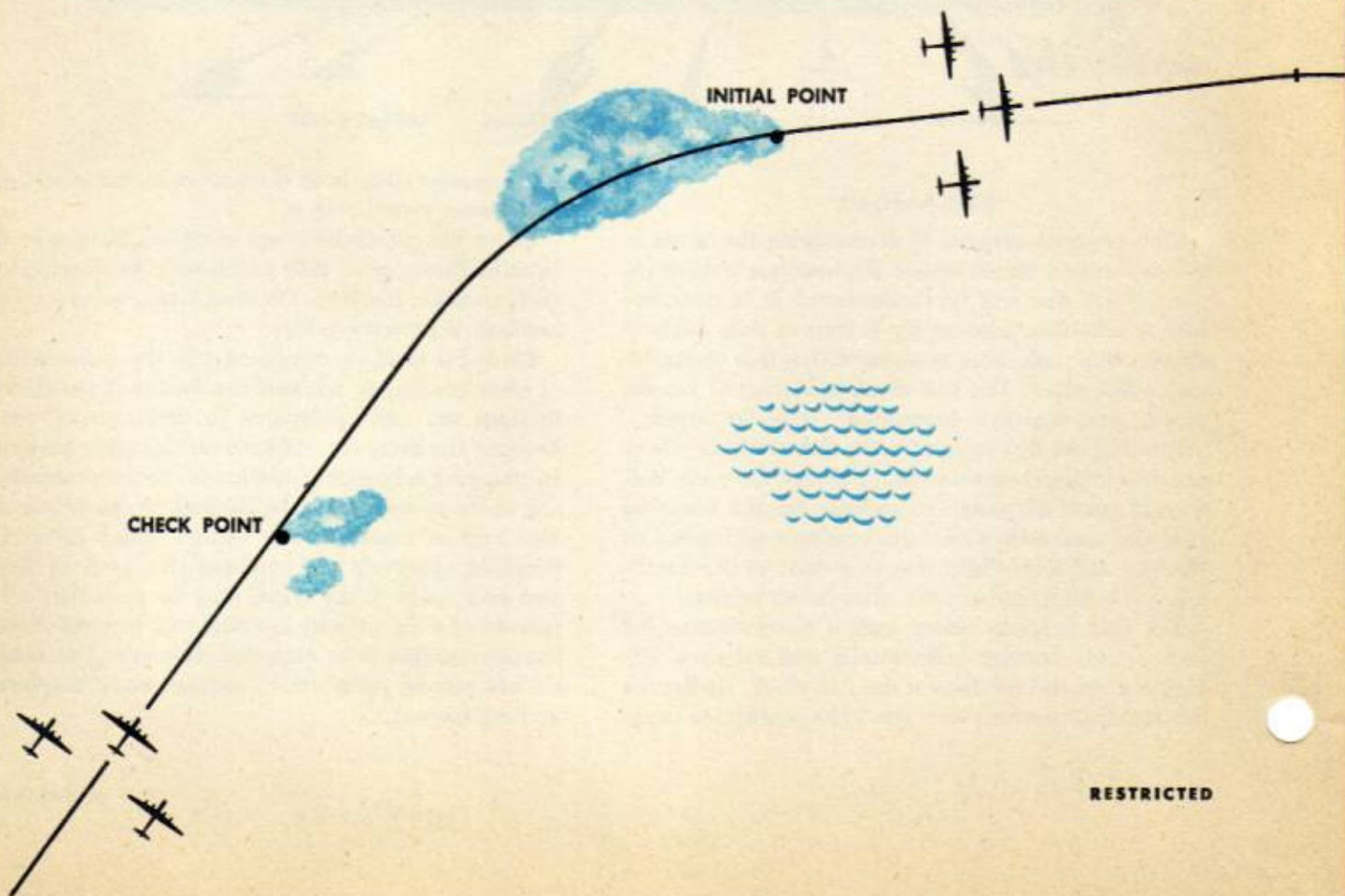

the shell bursts. It is important to remember that when flight corrections are made the airplane does not immediately change heading. It continues on course, then gradually goes into the proper bank. The greater the airspeed the longer it takes for a correction to be applied and the airplane to assume the desired attitude.

When heavy concentrations of fire are encountered, evasive action sufficient to avoid it carries the formation too far away from the target. Experience has shown that the best way to meet a heavy AA concentration is to fly straight through it. This gives minimum time over the defended area and increases the probability of placing bombs on the target.

Bombing from medium altitude presents a problem of increased accuracy in AA fire. The range of fire from enemy automatic weapons is from 0 to 10,000 feet, and although it cannot be aimed effectively above 7000 feet it adds considerably to the density of barrage type fire.

Effective evasive action on the bombing approach must be through irregular turns. The amount of turn

depends upon the type of airplane flown and the size of the formation. The duration of straight legs in your evasive action should be based on your altitude and the predicted amount of AA fire to be encountered.

Summary

Good evasive action is based on these points:

1. Make your course unpredictable.
2. Make your turns slowly and smoothly. Be sure to govern the amount of turn by the size of the formation. Position the formation so that it will be on proper axis of attack at start of bombing run.
3. Make most of your turns and long legs upwind of briefed axis of attack. Know your wind and use it to your advantage. Avoid drifting downwind of your intended axis of attack and having to make your bombing run upwind.

4. Use autopilot whenever possible. Fly manually, using PDI, only as last resort.

Black puffs in the sky are spent shells. Don't try to evade them. They're harmless.

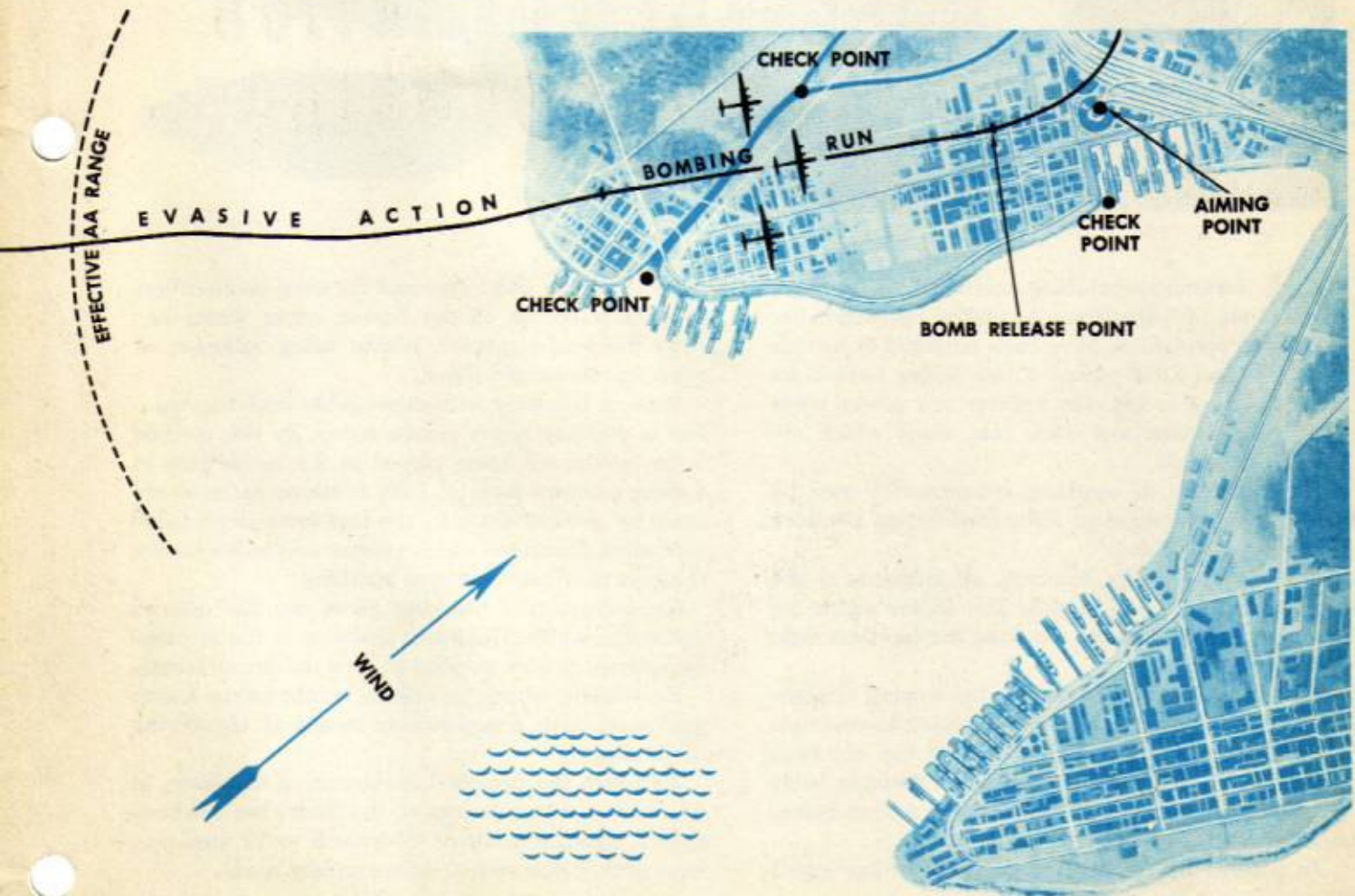

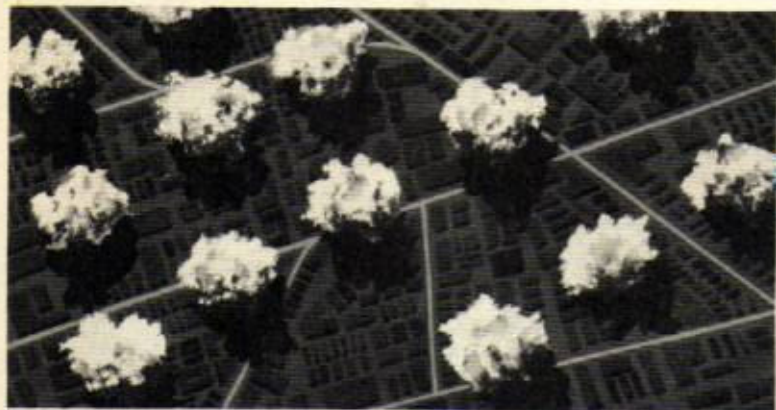
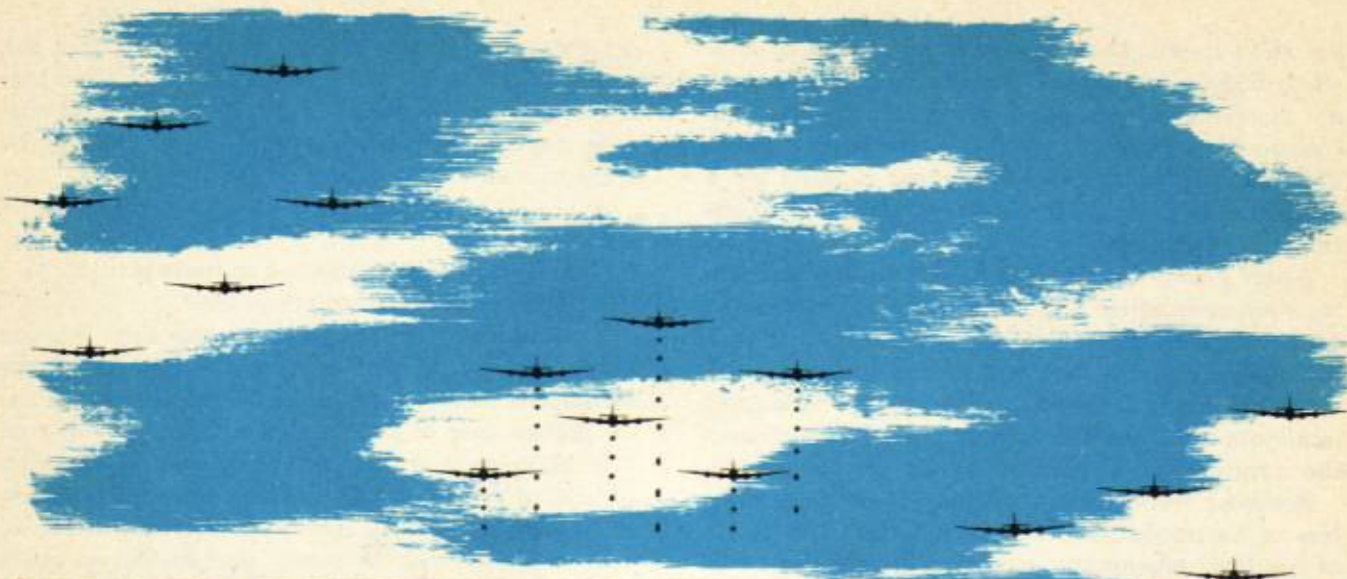

FORMATION BOMBING

Early formation bombing consisted of bombing in elements of 3 airplanes. As enemy opposition has increased, formations have been enlarged to include 6, 12, 18, and 21 airplanes. These larger formations are employed to provide heavier fire power when deep penetrations are made into areas which are heavily defended.

Two methods of bombing are normally used by formations of airplanes: individual range bombing and pattern bombing.

In individual range bombing, all airplanes in the formation carry bombsights. The leader sights for range and deflection and the wing bombardiers sight for range only.

Because the bombing platform in a wing airplane is unstable while the airplane is trying to maintain formation, individual range bombing has not been especially effective. It has resulted in patterns being scattered and inaccurate with bombs falling before and behind the target.

In pattern bombing, the lead bombardier sights

for both course and range and the wing bombardiers drop their bombs on the leader, either when they sight the lead airplane's bombs being released, or upon a prearranged signal.

Pattern bombing with dependable lead bombardiers is yielding better results today. By this method more bombs are being placed in the target area in a more compact pattern. Best bombing patterns are made by groups which fly the best formations. Good formation flying and quick release on the leader are the keys to effective pattern bombing.

Good formation bombing gives you the desired pattern in **width**. The intervalometer in the airplane is designed to give you the desired pattern in **length**.

Remember, when you release bombs on the leader you must have a dependable means of identifying his bombs.

Although the practical maximum of airplanes in a formation which bombs off the leader has not been agreed upon, formations of from 6 to 12 airplanes have proven successful and are widely used.

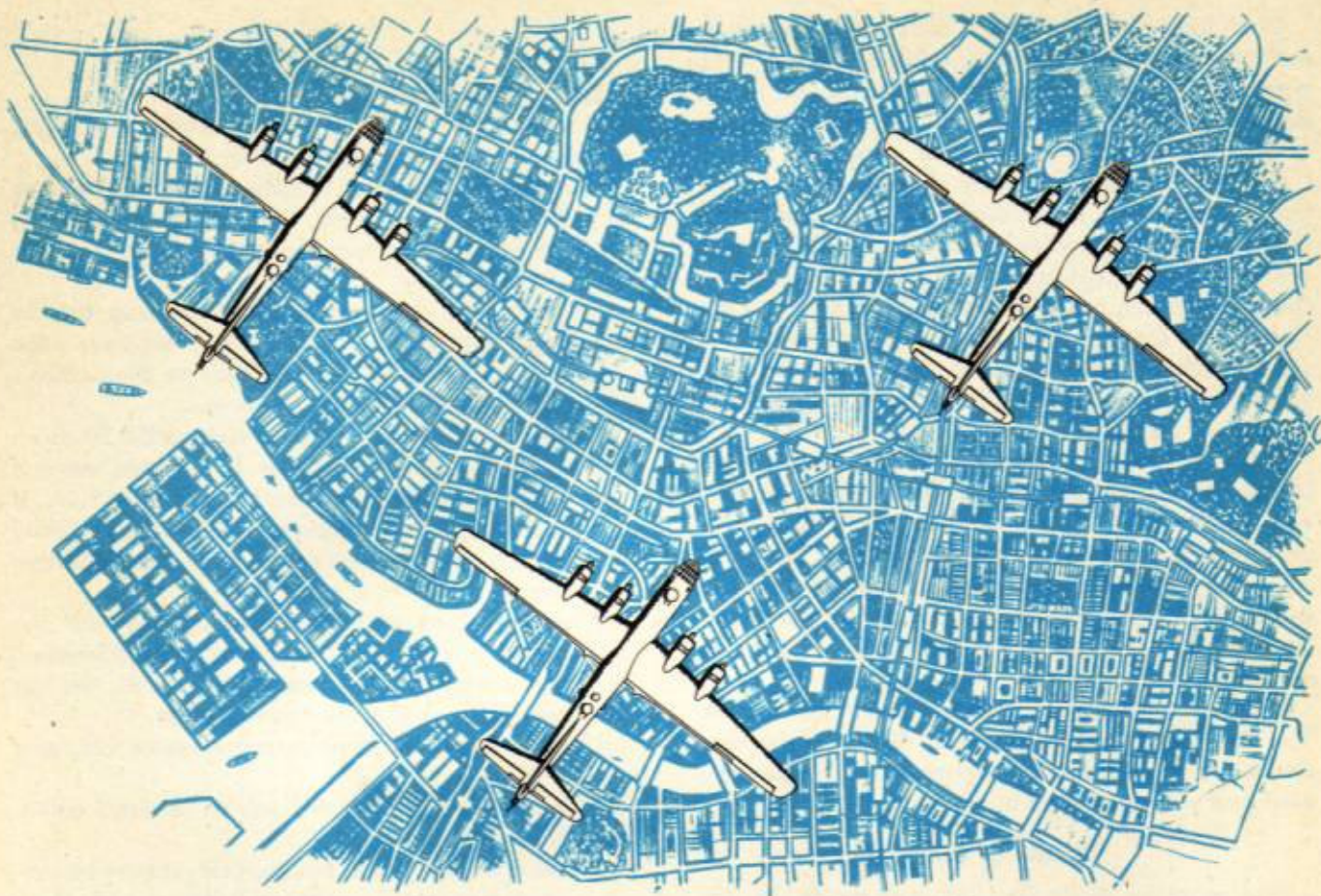

HIGH ALTITUDE BOMBING

Bombing which is done from an altitude of 15,000 feet and above is commonly called high altitude bombing. However, that does not imply bombing from the maximum or service ceiling of your airplane. The bombing altitude must be chosen to permit successful destruction of the target without too great a loss in men and equipment.

If you can bomb a target successfully from 15,000 feet without unduly jeopardizing the safety of your crew and airplane, do not bomb from a higher altitude. You will reduce accuracy by doing so and you may have to go back a second time to finish your job.

Effective bombing results demand your utmost in technical skill and accuracy. They also demand painstaking study of the target and target area. With the aid of maps, photos, and target guides, you must fix a picture of the target so firmly in your mind that you can bomb successfully even when only a part of the target area is visible.

Bombing Approach

Before trying to locate the IP itself, identify the larger landmarks and terrain features near it. The IP is easier to find if you first locate the area surrounding it.

Work with the navigator to locate the IP by pinpointing the most prominent features. But don't rely entirely on him to find your check points for you. If you can't locate the IP with certainty but have identified several check points around it you are justified in making your turn on the briefed axis of attack. Don't go fishtailing all over the sky trying to find a dot on the map from 15,000 feet or higher. Make sure you turn on the correct heading and hold it until you have identified the check points to the left and right of the course, then to the left and right of the target. Then narrow down your vision and your course.

Don't look too far ahead for the target. Keep yourself oriented on check points. Well chosen check points help you time your bombing run and establish an approximate course and range synchronization before the target itself is in sight.

Because it's hard to tell by check points how far you are from the target and how long it will take to get there, learn to use the sighting angle to make these estimates. It is your most reliable means. Use the graph which has been prepared to give you the distance to the target at any sighting angle and at your bombing altitude. Use your predetermined groundspeed to estimate the time it will take to cover that distance.

If the target is obscured by smoke from previous bombs or by a smoke screen, place the crosshairs and synchronize on a check point along the axis of attack as close to the target as possible. Then displace the crosshairs to the approximate location of the target. By using the computer grid or some similar device, you can do offset aiming with reasonable accuracy.

During the bombing approach the airplane is yours. You are responsible for doing or directing the evasive action. Speak up. Let the crew know what you need and when you need it.

Bombing Run

You must be ready for flak and rough air. Although the gyro has been leveled the bubbles may shift erratically. **This does not necessarily mean that the gyro is tumbling.**

On a bombing run of average length, level your gyro bubbles once and the gyro will maintain the level you establish. On a long bombing run, minor leveling adjustments may be necessary. Do not cage and uncage the gyro on the bombing run as a substitute for good leveling. **The caging knob is for caging the gyro. It is not a leveling knob.**

If you find the bombing run too short, or if weather or man-made conditions obscure the target, you may have to make a new bombing approach. Decide on your new plan of action quickly. Let the pilot know what the conditions are. He not only will listen but will usually act promptly on your advice.

A bombing run that is too short may ruin the whole show. If you don't do the job right the first time you will probably have to go back and the enemy will be ready and waiting. If you miss the IP, you may have to hurry your procedure to the detriment of your accuracy. A well timed run with systematic procedure and undivided concentration is your best bet for efficient bombing.

Hints

Dress warmly, but not tightly.

Always use the oxygen mask microphone, making sure the connecting plugs fit firmly.

Use whatever de-icing facilities are available, such as heating pads, air blasts, ventilators, and heating fans, to remove ice from the inside of the plexiglas nose.

To minimize condensation and frosting on the bombsight eyepiece and telescope window, wipe them with a lint-free cloth or remove them. Make use of your bombsight heating covers.

At low temperatures, before reaching the IP check to see if the optics are fogging. If they are, remove the telescope window and insert the heater tube. If you notice fogging in sufficient time before you need to use the bombsight, you can clear the condensation this way.

Always discuss each bombing mission with the pilot before takeoff. The better you both understand in advance what each of you is going to do, the less likelihood there is of a misunderstanding.

Utilize all the aid that your navigator can give you.

Always follow the briefed course to avoid colliding with other airplanes.

If you are deputy lead bombardier, always be prepared to take over if something happens to the lead airplane.

Raise and lock your release lever before you start the bombing run. On the bombing run you are apt to overlook it.

When bombing with the use of PDI, be sure your pilot understands what you are doing. Always make clear to him what you want him to do. Give him a chance to follow your corrections.

The optics blacks out if a steep bank is made. Your gyro has not necessarily tumbled. The optics returns to normal when the airplane levels out, and the eyepiece is again above the telescope.

When a smoke screen obscures the target, attack down the ground wind if possible. Frequently you can see between the smoke furrows and locate check points which you can use for offset bombing.

When many groups attack one target, most of them find it obscured by bombfall smoke. Be well prepared to do offset bombing when this happens. Never aim at top of smoke columns.

In selecting the proper axis of attack for a bombing run consider: position of sun; selection of a suitable IP; shape of target; wind direction and speed; AA fire around target.



MEDIUM ALTITUDE BOMBING

The operation of the bombsight and the general bombing problem at medium altitudes are essentially the same as at high altitudes. However, there are a few differences:

Medium bombardment is employed principally to neutralize enemy airfields and to cut his lines of communication. Because of limited operational range, medium bombardment is used in strategic bombing only to supplement heavy bombardment.

Targets most commonly selected for medium bombardment are marshaling yards, railroad and highway bridges, and airfield installations. When it is used in direct support of ground forces, troop concentrations and ammunition and supply dumps also become objectives. In the bombing of bridges or any other rectangular targets, it has been found that an axis of attack at an angle of 45° to 90° with the target's longitudinal axis offers the best opportunity for a direct hit.

Formations

Careful analysis of past bombing records of medium and heavy bombardment reveals that bombing accuracy definitely increases as bombing formations decrease in size. The amount of enemy air opposition expected usually dictates the type of formation

used for bombing. However, for targets such as those encountered in medium bombardment it is believed that the most effective and accurate method of attack is by flights of 6 airplanes so spaced as to give the desired pattern.

In each flight of 6 airplanes the lead bombardier sights for range and deflection while the wing bombardiers drop on the leader. Medium altitude missions are usually carried out with pre-set data subject only to minor corrections. That is because runs are shorter and the object is to get over the target and out again in the shortest possible time. However, bombing accuracy should not be sacrificed in the attempt to avoid flak.

Teamwork is of paramount importance because many medium bombardment airplanes are not as yet equipped with autopilots. Evasive action with short bombing runs is almost indispensable at medium altitudes because of the intensity of AA fire by automatic weapons and the greater degree of accuracy obtained by heavy guns. The pilot must develop a high degree of skill in following the PDI. He must know what to expect from the bombardier. When he does, he can fly the airplane in such a way to provide maximum help for the bombardier on the bombing run.



MINIMUM ALTITUDE BOMBING

Minimum altitude bombing has been and is being carried on in Pacific theaters with a high degree of success against targets both on land and at sea. Pre-determined computations are pre-set into the bomb-sights. Tactics employed in such attacks vary with the target.

Minimum altitude bombing against shipping or pinpoint targets may employ a single airplane or a coordinated attack of two or more airplanes, depending upon expected opposition. The practice is to drop 3 bombs, spaced to bracket the target. The second bomb should be a direct hit.

Minimum altitude bombing is often accomplished from a line-abreast formation (for maximum simultaneous strafing power) of as many airplanes as are necessary to cover the target area. Bomb fuzes used are such that explosion does not occur until the airplane is a safe distance away. The bombs can be dropped in train or toggled out at opportune intervals, depending upon the size and type of target. With some types of bombs, it is often necessary for the bomber to increase altitude slightly before releasing them. This makes the bomber more vulnerable to enemy fire from automatic weapons.

The **advantages** of this method of bombing are:

- Element of surprise.
- Good visibility of target at time of release.
- Reduced exposure to heavy ground artillery.
- Photographic possibilities.

The bomber can also strafe, a form of attack which restricts enemy ground observation.

Short approaches are possible and evasive tactics can be used until almost at bomb release point.

The **disadvantages** are:

The bomber is within range of automatic ground weapons and flak towers.

Airplanes flying line-abreast formation cannot veer much from course and must travel a given path.

Hints

When meeting fire from automatic weapons:

Fly straight through area as rapidly as possible.

Take advantage of terrain features which will confuse the gunners, making it difficult for them to distinguish between airplane and background.

Try to lay out a course in advance, or at the last moment if necessary, which will make the enemy gunners' brief problem as difficult as possible.

You can often surprise the enemy by:

Taking advantage of masking characteristics of terrain, such as mountain peaks, craters, jungle growth.

Varying axis of attack. There are certain desirable approaches to every defended area. Because they are best, the defense is usually set up with these in mind. If you can avoid these approaches you achieve a certain amount of surprise.

Use speed, terrain, and weather to full advantage.



Although there is no essential difference in bombing technique in the various theaters of operations, you must always consider the following factors in the particular theater in which you operate:

- Type of weather in target area
- Similarity of terrain which makes targets hard to identify
- Seasonal variation in terrain appearance
- Type and magnitude of enemy defenses

Depending on the theater, targets vary in tactical and strategic importance. Your sighting methods are different when you make use of radar rather than visual means.

Learn all you can about the theater to which you are assigned, from experienced men on the spot. They can give you tips on target identification, evasive action, camouflaged areas, which you will never find in books.



European Theater

In this theater a vast body of experience in bombardment has been accumulated by the several air forces involved. Meteorological data and information on enemy defenses are extremely comprehensive.

Missions are planned with meticulous attention to detail. Wind, cloud formation, AA defenses, and proximity to fighter airfields are all considered in planning the route to the IP.

The IP for bombing approaches invariably is a readily identifiable landmark located as near the target as possible. Some attempt is usually made to confuse the enemy radio direction finders by laying the course of the formation midway between two strategic targets, by dispatching diversionary bomber raids and fighter sweeps, or by using chaff or a similar radar-jamming material.

Formations Used

The 3-plane element in a V is the basic unit. Nine-plane flights of 3 V's are preferred for defensive fire power. Individual flights have the same relative position within larger formations. When more than 27 airplanes are used on a mission, separate formations follow slightly different courses.

For bombing approaches, the javelin formation, stepped up when flying into the sun and stepped down when flying away from the sun, is most often used. One of the defensive formations is a tight but staggered grouping with room for individual evasive action.

Fighter escorts vary with the kind of mission.

One type calls for top cover, medium cover, and close escort. This type is limited by the operating ranges of fighter aircraft.

For deeper penetrations, bombers rendezvous with fighters at a point en route, thus enabling fighters to climb while traveling toward the objective. This calls for split-second timing.

Targets and Enemy Defenses

In northern Europe, our bombing missions are directed largely against strategic targets. These targets include oil refineries and tank farms, airplane factories, shipyards, foundries, transportation and communication centers, chemical plants, and industrial installations such as locomotive, truck, and Diesel engine works, rubber and abrasive plants. Difficulties arise in this theater because of the close proximity of cities to each other. Their similarities can be most confusing when adverse weather conditions prevail.

In defense of vital objectives, the enemy uses smoke screens, camouflage, and anti-aircraft fire. Smoke screens are inexpensive to produce and successful in operation. They are being used more and more for all types of targets. To counteract smoke screen defenses, weather reconnaissance planes are sometimes sent ahead to observe smoke and report direction of surface wind and smoke to oncoming bombardiers. In this case a bombing run can be made from upwind of the surface wind. This greatly increases the possibility of sighting the target, down the smoke furrows.

Varying shifts in fire power and changes in defensive technique are employed to baffle our forces and also to protect vital installations. A target which is found to be lightly defended on one mission may be heavily defended on the next, or vice versa. This may be because destruction of a similar installation

elsewhere has increased this one's importance to the enemy. On the other hand, the effectiveness of our bombing on the first raid may have made further defense of the target useless. With the retreat of the German armies into their own homeland, concentrations of AA are much heavier around the vital objectives which remain.

Fighter opposition to our bombing formations varies with the degree of surprise we have been able to achieve in attack, the number of enemy fighters available, and the weather.

In southern Europe targets are more likely to be tactical, although flights are often made over strategic targets such as oil refineries in southeastern Germany. Enemy troop concentrations, trains, and convoys came in for a large share of bombardment in the Balkan theater.

Although bad weather—always a problem in this theater—necessitates considerable use of radar bombing techniques, fighter opposition at such times is generally not great.

Weather

Weather in this area alternates between short periods of stormy and fair conditions. Thus, short range weather forecasts are of primary importance to the bombardier. Because of the weather-gathering facilities and accurate short range forecasts available in this theater, meteorological bombing data can be computed fairly accurately just before takeoff.

Frontal storms are the key to an understanding of flying weather over this area. In the vicinity of a strong front, airplanes encounter heavy and widespread cloud cover, rain, hail or snow, icing, violent winds, and turbulence. When no front is moving across the area, airplanes experience little interference from the weather, except for local cloud banks and occasional fog or haze.

Bombing operations cannot be confined to days of clear weather. Such days are too infrequent. Moreover, CAVU conditions are not necessarily ideal for bombing missions. Favorable flying weather is an advantage to the defender as well as the attacker.

In the case of an attack with incendiary bombs, flights are sometimes purposely made in difficult flying weather to achieve the increased fire damage that results from high winds which accompany a frontal storm.

The most dependable guide to the weather in the area in which you operate is your Group Weather Officer. Consult him frequently. You will find his advice invaluable.

Bombing Aids

Two valuable aids that have been developed and used successfully in this theater are the 5° funnel and the offset bombing computer grid.

The 5° funnel is printed on transparent paper and is a visual aid to accurate pilotage for the bombardier into the IP and from the IP to the target. It consists of a scale of lines radiating at 5° intervals from a point. The center line or axis of attack line is heavier than those on either side.

In using a 5° funnel, you should accurately draw on a navigation chart your pre-determined course

to the IP and from there to the target. Fix one funnel to the chart, preferably with transparent tape, so that the converging lines focus on the IP and the heavy center line lies over the course by which you expect to reach it. Fix a second funnel so that its lines converge on the target and its heavy line lies over the course from IP to target.

By comparing visual check points with your map and overlay funnels you can tell at a glance whether you are to the right or left of course and how much. You then can easily alter course sufficiently to return to your briefed axis of attack. You can also use funnel for orientation during evasive action.

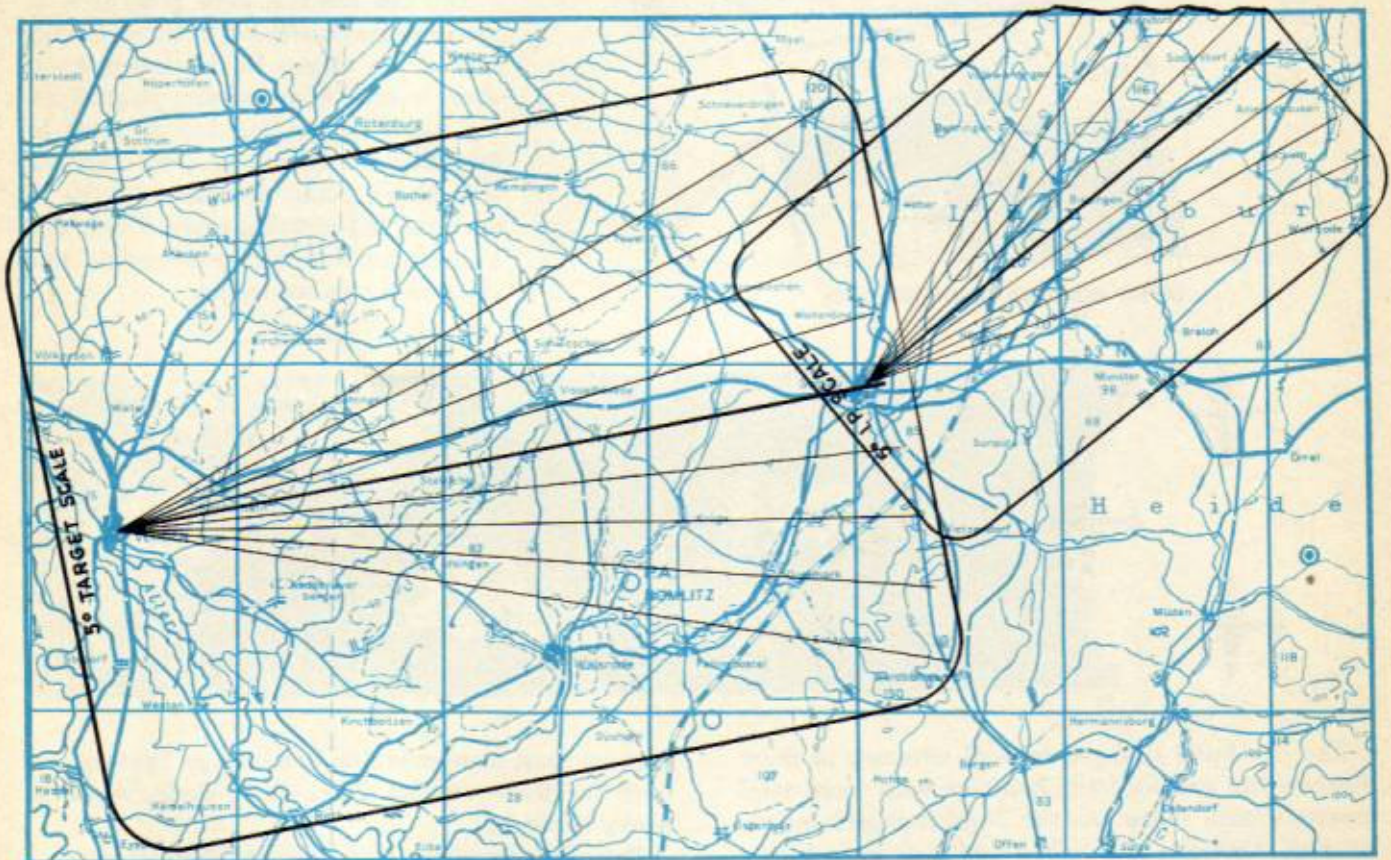

The offset bombing computer grid is a transparent device which can be fastened to the center of the target on a target chart and pivoted for any desired heading.

Each square of the grid represents 1000 feet. The horizontal lines mark off distance along the course. The vertical lines enable the user to estimate how far to right or left of his course a given point lies. At the right and left of the grid squares are columns of units of tangency headed by bombing altitudes ranging from 10,000 to 25,000 feet.

By synchronizing on a visible point, preferably on the near side of the target, you can determine with the aid of the grid how much to increase your sighting angle to displace the lateral crosshair on the target.

You should have the navigator's cooperation in order to use the computer grid. While you are making a synchronized bombing run on the closest visible check point in front of the target, the navigator aligns the heavy vertical line in the center of the computer grid so that it corresponds to the true

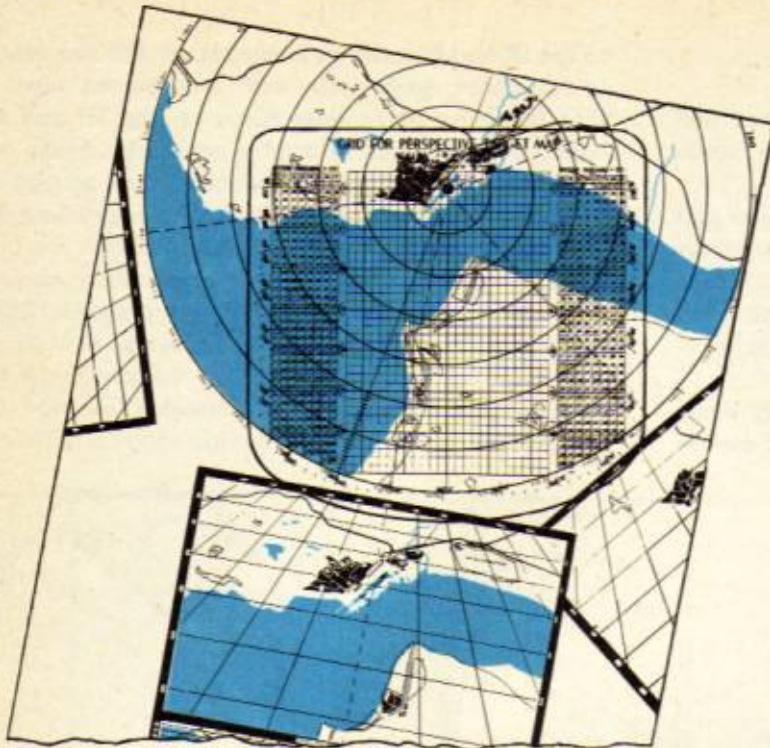

OFFSET BOMBING COMPUTER GRID

course of the airplane on the target chart. He locates on the chart the object being used for sighting. Then, on the overlying computer grid he follows the horizontal line on which that point lies, across the grid to the appropriate bombing altitude column. He is then ready, when you are synchronized, to read off to you the unit of tangency necessary to displace the lateral cross-hair on the target. The nearer the reference point is to the target, the smaller the possible error.

You can use this same procedure to synchronize on a check point on the far side of the target. In this event, however, instead of increasing your sighting angle by the number of units of tangency shown on the grid scale for that check point, you would have to decrease the sighting angle. Don't use a check point on the far side of the target except as a last resort.



Far Eastern Theaters

The decidedly changed tactical situation in these theaters has provided our bombers with more vital targets within range. As the Japs' southern march towards Australia was halted and they were forced to withdraw, they worked frantically to develop a new ring of defenses in the regions closer to their homeland. We have bombed these targets and Jap shipping with new tactics which include:

Minimum altitude bombing by heavy, medium, light, and fighter bombers against land or sea targets. Depending upon the type of target, attacks are made from 500 feet to below masthead level. Best results against ships have been obtained by toggling 3 bombs in rapid succession so that one strikes the vessel at the water level, the second hits it broadside, and the third hits the deck. Usually, the fast-

est and most maneuverable bombers or fighters are used for these attacks. Sometimes, range requires heavy bombers.

Parachute bombing, using a series of small bombs, each equipped with a parachute. The bombs are carried in 40 or more separate slots in the bomb bay. They are released either singly or in bunches. Releases are usually made from about 75 feet. The parachute slows up the bomb's fall, giving the bomber a chance to get away before the explosion takes place. The bombs are usually anti-personnel fragmentation bombs which spread death and destruction to men, light vehicles, and airplanes for many yards. They are highly effective in clearing out jungles, swamps, and areas with short undergrowth where snipers are hiding.

Night bombing, using moonlight or flares to make it possible to locate the targets. With additional experience in night flying, night bombing has produced excellent returns. Recently these night and dawn missions have adopted a low-level, glide bombing technique with hits averaging as high as 50%. B-17's have maneuvered around into position to start the glide between 3000 and 4000 feet. The pilots flew directly at the target and leveled out as bombs

were released from as low as 100 to 200 feet. Immediately upon bomb release the copilot shoved the throttles forward and the airplane followed a straight course away from the objective. Five-second delay fuses were used.

This type of bombing has been used on targets at the most heavily defended enemy-held positions. Damage to Allied aircraft from ground and shipping fire has been negligible.

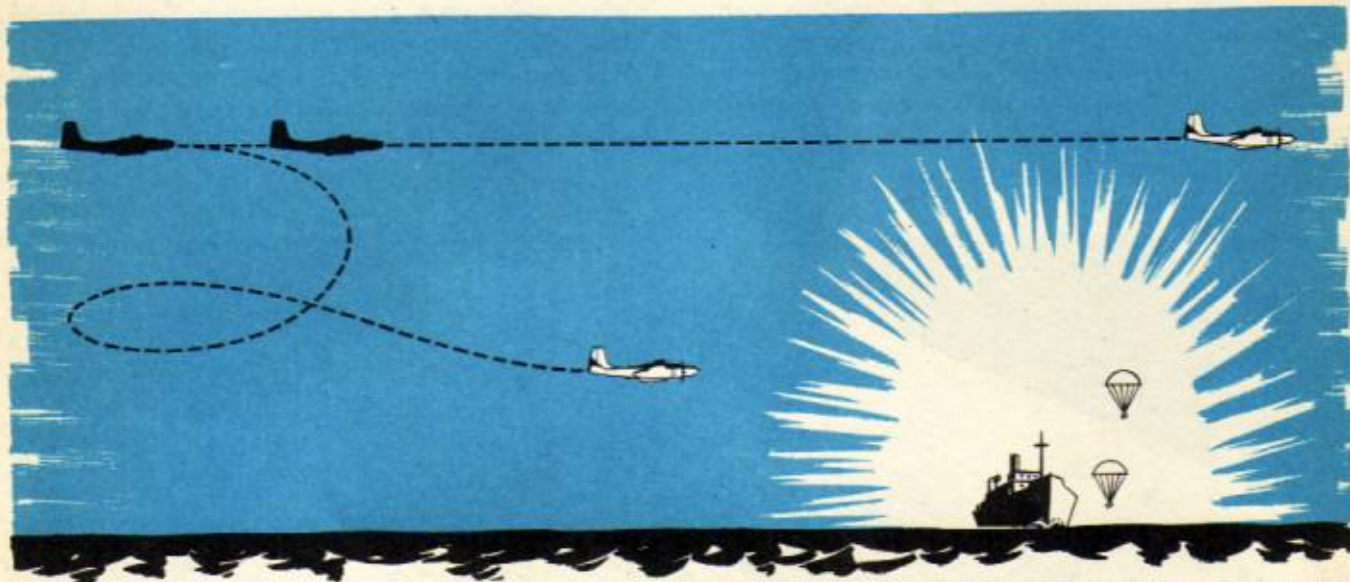

Types of Missions

In the South China Sea, Allied flyers have carried out effective sea-sweeps against targets of opportunity such as junks, barges, steamboats, and tugs. In occupied China, docks, river wharves, marshaling yards, railroad bridges, troop concentrations, ammunition dumps, and airfields are day-to-day targets. Medium bombers are often used in support of the Chinese army.

In the Burma and India theater, targets for very heavy bombers have included marshaling yards, naval bases, and oil refineries. Heavy bombers have gone out on search missions to attack convoys.

In Japan proper, bombing has been of a strategic nature against important war plants and industrial targets in the closely located centers on both of the principal islands.

Enemy Defenses

Since bombing attacks have been undertaken against the Japanese mainland and large centers in Japanese hands, anti-aircraft fire by the enemy has improved in accuracy up to 20,000 feet.

Searchlights are used and anti-aircraft emplace-

ments camouflaged. Occasionally barrage balloons have been encountered, sometimes floating at altitudes of 15,000 feet.

Weather

In the South Pacific area, weather does not seriously hamper air operations except in the occasional tropical cyclones (typhoons) and in storms moving along the south polar front. In cyclones weather is extremely violent and, because they are all slow-moving storms, operations may be restricted for up to 10 days. In the frontal storms, however, weather is less violent. The storms move much faster and operations are held up for short periods only.

Over Japan extremely high winds, often exceeding 175 mph by day and reaching 265 mph at night, have led to large errors in navigation. These winds produce an exceptionally large drift angle, making it difficult for bombardiers to set up course. The winds also give bombers a bumpy, weaving motion which increases the difficulties of bombing accurately. In general, best flying conditions over Japan occur in the late summer.

Because of the rapidity with which weather can change in this area, long range forecasting is not

proving satisfactory. Although such forecasting is as accurate as facilities allow, it is not always reliable. You may find it hard to obtain an accurate bombing altitude because of fluctuation of weather conditions in the target area.

Bombing Aid

An offset bombing computer grid, similar to that used in the European theater, has been developed in the Far East. There, however, it is printed on each perspective target chart. Instead of listing units of tangency in columns headed by bombing altitudes, it lists time from target in seconds in columns headed by groundspeeds of from 200 to 350 mph.

The offset aiming problem is solved by synchronizing on a good check point near the target. The navigator locates the check point on the perspective chart and aligns the center line of the grid with it. He then follows the horizontal line on which the point lies across to the groundspeed column of the grid. There, he reads off to you the time in seconds which should elapse between the instant the indices meet and the instant of bomb release. When indices meet, start your stop watch. Toggle bombs after required number of seconds has elapsed.

Perspective target charts also are being used which have printed on them the same type of offset bombing grid used in the European theater.

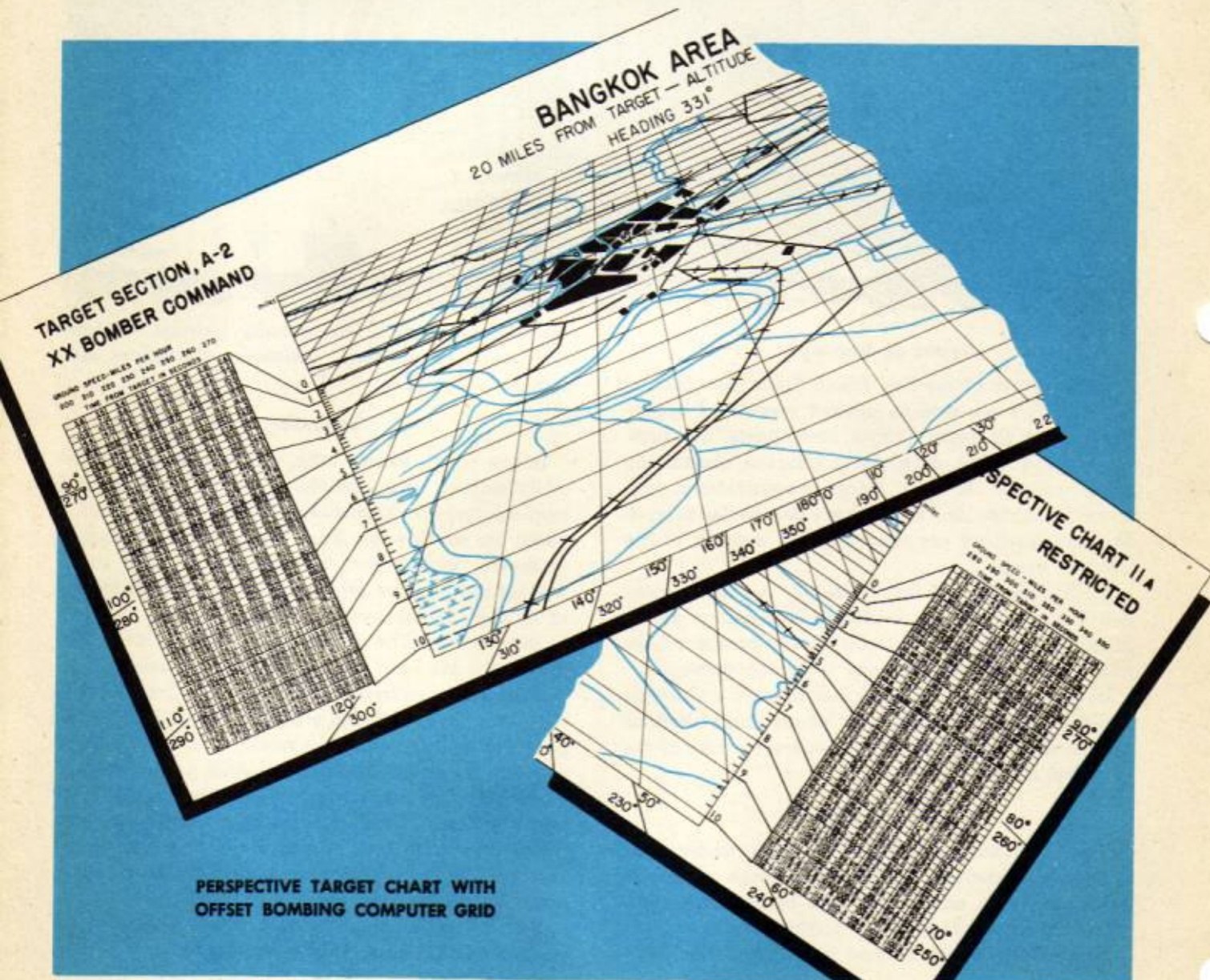

MANEUVERING TARGETS



Comparatively few bombardiers have ever bombed a maneuvering target. Yet, shipping comprises a large percentage of the objectives in some combat zones. While you may frequently bomb ships at anchor, often the ships you bomb will be traveling the sea lanes.

The M-series bombsight was designed for bombing fixed targets, or targets moving in straight lines. Most ships turn and maneuver when enemy bombers come over. Therefore, to bomb ships a special procedure is needed.

You may think that large naval vessels can avoid being hit by seeing the release from your airplane and then executing a sharp turn. This is not true. But it is a popular belief, because of the frequent misstatement that in combat many ships have been missed because they went into a turn after the bombs were released. There was no check on the bombardier's synchronization and aiming point, however. We can assume that if the ships had kept on course the bombs would have missed anyway.

Look at the picture of the misses on the Jap cruiser and study the turn characteristics. Note that the ship must have been in a well-developed turn prior to bomb release and that the misses were due to poor technique on the part of the bombardier.



Jap cruiser missed by bombs dropped from 15,000 feet

Vessels may be traveling a straight course during part of the bombing run and then start to turn. The rudder of the vessel does not take effect immediately, but you can recognize the direction of turn by the swirl of white water at the vessel's stern. This swirl is always to the side on which the turn is being made. A swirl of white water to the right of the stern signifies a turn to the right and vice versa.



Speeds and Rates of Turns

Speeds of vessels vary from practically none for crippled vessels to as high as 30 to 40 knots for destroyers and even higher for PT boats. The rate of turn of such targets varies with the speed of the ship and the amount of rudder employed.

Large vessels like battleships and aircraft carriers require 15 to 20 seconds for the rudders to take effect. If you were bombing them from 12,000 feet with an ATF of approximately 30 seconds, they would be able to turn only a few yards after observing your bomb release. Ships like tankers and freighters should be easy targets for you when bombing from altitudes between 6000 feet and 12,000 feet. Their radius of turn is large and their speed slow.

You should know something about the problem of finding the amount to offset aiming point. Squadron or group bombardiers often have to make up tables for offset aiming points on vessels in turns.

Consider the problem in general terms. The degree of turn and radius of turn are never too exact, anyway. Assume that at 12,000 feet you are tracking a vessel that has been traveling in a straight line. Just before bomb release the ship starts into a turn. You estimate it to form a 30° angle with the track it had been making. The ATF is about 30 seconds.

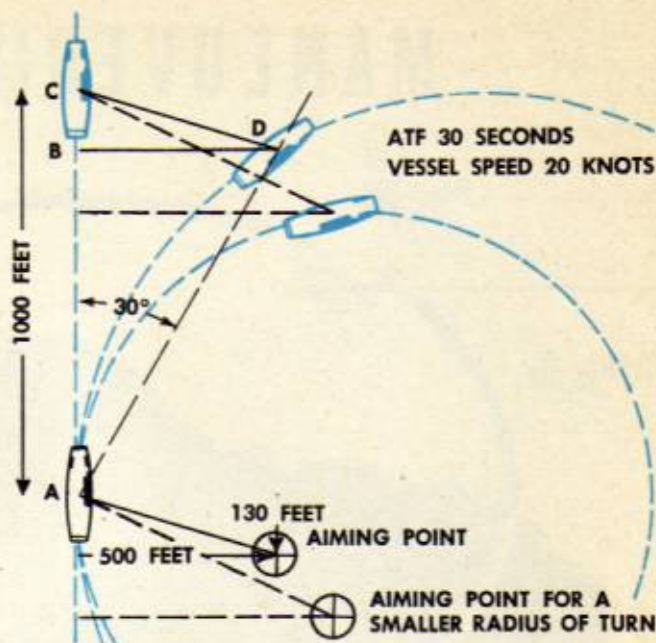

Theoretical aiming point for a turning vessel after obtaining synchronization on its foremast and just prior to release.

By using simple arithmetic you can figure that if the ship were moving at approximately 20 knots it would have moved from position A to C, a distance of approximately 1000 feet. But, the ship actually has moved from A to D, also approximately 1000 feet. If you did not displace your aiming point after you saw the ship start to turn, your bomb would hit at C, over and to the outside of the turn. Consequently, the basic rule for bombing maneuvering targets is:

Aim to rear of target motion and inside its turn.

You must determine the distance to move your aim from practice or from tables. You always have to estimate the speed of the target and the degree of turn. Tables are relatively simple to compile.

In the sample problem, by trigonometry, the distance $BC = AC - AB$. $AB = AD \times \cos 30^\circ = 1000 \times .866 = 870$ feet, approximately. So, the aiming point is displaced 130 feet to the stern of the vessel. (The aiming point is always displaced to the stern of the vessel when it is traveling forward.)

By this same process of computing, the distance $BD = AD \times \sin 30^\circ = 1000 \times .5 = 500$ feet. So, the aiming point is displaced 500 feet to the inside of the turn. Squadron or group bombardiers should compile tables for different altitudes and different target speeds and degrees of turn. They should use plane geometry and figure them for circles rather than straight angles, as in the above problem.

The same system of offsetting the aiming point is used in bombing ships which are in well-developed turns. Take the example in the picture. In the previous example it was assumed that the vessel made a 30° turn immediately after the rudder was applied. You must remember that only small, fast, highly

maneuverable vessels can even approach that type of course. On slower vessels your aiming point need not be offset so greatly because it takes some time for the rudder to take effect before the ship goes into the turn. Now, consider a ship that is already in a developed turn:

AMOUNTS OF DEFLECTION OFFSETS FOR MANEUVERING TARGETS IN TURNS

Diameter of Turn: Speed:		1600 yards 30 knots	1600 yards 20 knots	1200 yards 30 knots	1200 yards 10 knots	800 yards 20 knots
Bombing Altitude	ATF	Offset	Offset	Offset	Offset	Offset
1600 feet	10 secs.	50 feet	20 feet	60 feet	20 feet	50 feet
3500	15	110	65	150	30	120
7000	20	220	95	280	45	210
10,000	25	340	160	420	60	310
14,000	30	580	220	630	80	440
18,500	35	640	280	840	100	600
24,000	40	830	375	1080	130	780
29,500	45	1040	...	1370	160	...

AIMING POINT IS OFFSET TO THE INSIDE OF THE TURN. (Table taken from U. S. Navy statistics)

Procedure

Set up your AB computer as soon as you get in the target area. Plan on using about a 60-second bombing run when you swing onto the target. Pre-set the drift and dropping angle obtained from the wind solution on the AB computer. Keep the crosshairs on the target by double gripping both the course and the range knobs—until about 10 seconds before bomb release. Then, displace the crosshairs to the rear of the target motion and to the inside of its turn. Obtain the amount of displacement from tables or, better, from experience and practice.

Drop your bombs in train with a spacing equal to the width of the vessel. Best results are obtained by bombing in flights of 3 planes at medium altitudes, 6000 to 8000 feet being the best altitudes. Single planes do not get the coverage of bombs, while large formations are unwieldy in making last second corrections. Don't be afraid to be in a turn at bomb release. Unless you make a violent bank at instant of release, the bombs will fall along a line tangent to the turning circle at release point.

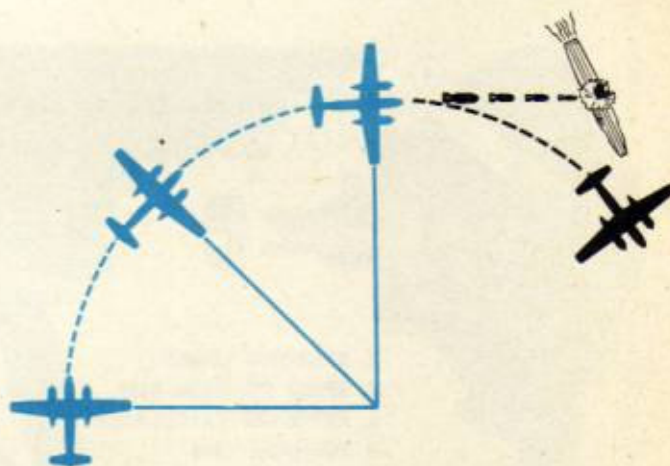

Don't be afraid to be in a turn at bomb release. Bombs will fall along a line tangent to turning circle at release point.

Summary

1. Use small formation with wing men dropping on lead plane.
2. Bomb from medium altitude.
3. Drop bombs in train with spacing equal to width of vessel.
4. Synchronize throughout bombing run.
5. Aim to rear of target motion, inside its turn.





Camera bombing helps the bombardier improve his ability to identify targets, especially those in confusing industrial target areas. Also, it is a closer imitation of an actual bombing mission against enemy objectives than dropping practice bombs on a shack in the desert. The camera bombing mission is successful if the bombardier is able to obtain a picture of the briefed target as his apparent aiming point. To make it even more like an actual mission, he also takes a picture of the IP. The pictures he brings back give him a good idea of the kind of hit he would have made with a bomb.

For low or medium altitudes, the simplest equipment for camera bombing is the A-4 35 mm. bomb spotting camera. With this camera the bombardier

takes a picture through the bombsight optics at the time he would have released a bomb and, again, when the airplane is directly over the target. Thus, in addition to improving his ability to identify targets, the A-4 camera gives him a means of checking his synchronization.

For high altitude camera bombing, the best equipment is a combination of the B-7 camera intervalometer with either the K-22 or K-24 camera mounted in the airplane's camera well. The bombardier pre-sets the ATF on the camera intervalometer. When the airplane is at the simulated bomb release point the bombsight's automatic release mechanism starts the camera intervalometer, which trips the camera when the pre-set time expires.



1. Test tension on winding crank to see that spring motor is properly wound.

2. Trip starting lever to see that spring motor runs.

3. Check footage dial to make sure there is sufficient unexposed film in camera.

4. Make proper shutter speed setting. For normal light, 8 frames per second is best.

5. Make proper aperture (f) setting. Best settings are f 4.5, f 5.6, and f 8. In rough air, only first 2 settings assure full frame.



Aerial Procedure

1. Attach proper lens for bombing altitude to be flown. Use following guide:

Bombing Altitude	Lens (focal length)
500 to 2000 ft.	1"
2000 to 4000 ft.	2"
4000 to 12,000 ft.	6"
Above 12,000 ft.	10"

2. Be sure that camera adapter is properly attached to camera lens.
3. Set proper disc speed and trail into bombsight.
4. Set sighting angle index at 0° .
5. Hold camera vertically above bombsight with camera adapter and lens set into bombsight eyepiece. Take picture of IP when directly over it.
6. With bomb bay doors closed, make normal bombing approach and run.

7. Immediately after indices pass, set camera adapter and lens into eyepiece and take brief picture of target. Don't make any adjustments of bombsight after indices pass.

8. Wait until sighting angle index has driven almost to 0° , then take another brief picture of target.

Pilot must hold same airspeed, altitude, and heading as on bombing run until plane is directly over target and you've taken second picture of it.

K-22 OR K-24 CAMERA (using B-7 camera intervalometer)



B-7 CAMERA INTERVALOMETER

Preflight Procedure

1. Check vacuum connections and positions of vacuum switches (in VH aircraft only).
2. Press STOP button on camera intervalometer to clear it.
3. Turn camera switch ON and have crew member check to see that camera operates properly when you press single exposure button.
4. Set camera intervalometer dial for any ATF. Set selector switch at NT ORIEN. Check to see that camera intervalometer starts when bombsight indices meet with release lever up. If camera intervalometer is not wired to bombsight you must push START button when indices meet.
5. Make sure camera trips when ATF pre-set on camera intervalometer runs out.
6. Turn camera switch OFF.
7. Check to see that photographer has set TIME AFTER night orientation closure adjustment to 3 and TIME BEFORE night orientation closure adjustment to 3. These settings insure 2 pictures taken 6 seconds apart. That spacing is desirable for stereoscopic interpretation, which is a help in case you want to score the theoretical point of bomb impact on final photo.

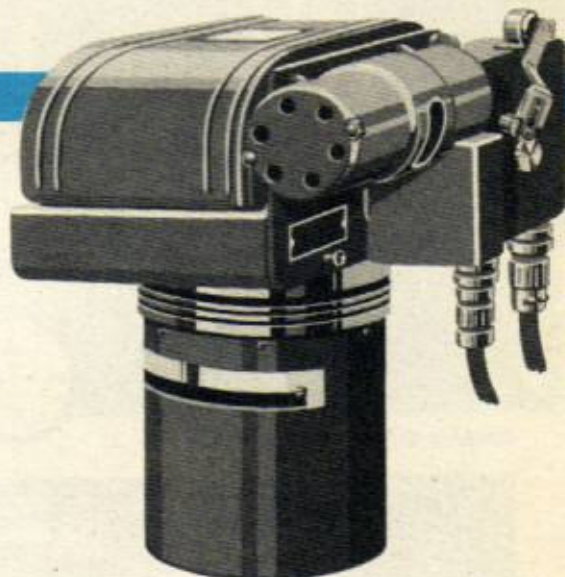

K-24 AIRCRAFT CAMERA

Aerial Procedure

1. Set proper disc speed into bombsight. Set 0 trail.
2. Make normal bombing approach with bomb bay doors closed.
3. Have crew member open camera hatch doors.
4. Press STOP button on camera intervalometer to clear it.
5. Set interval dial on intervalometer for ATF.
6. Turn camera switch ON.
7. Turn camera intervalometer selector switch to NT ORIEN.
8. When over IP, press single exposure button to take picture of it.
9. Make normal bombing run, with bomb bay doors closed. If bombsight has not been wired to camera intervalometer, you must press START button on camera intervalometer just as indices meet. The camera intervalometer trips the camera both before and after the pre-set ATF expires.
10. At completion of mission, press STOP button on camera intervalometer to clear it.

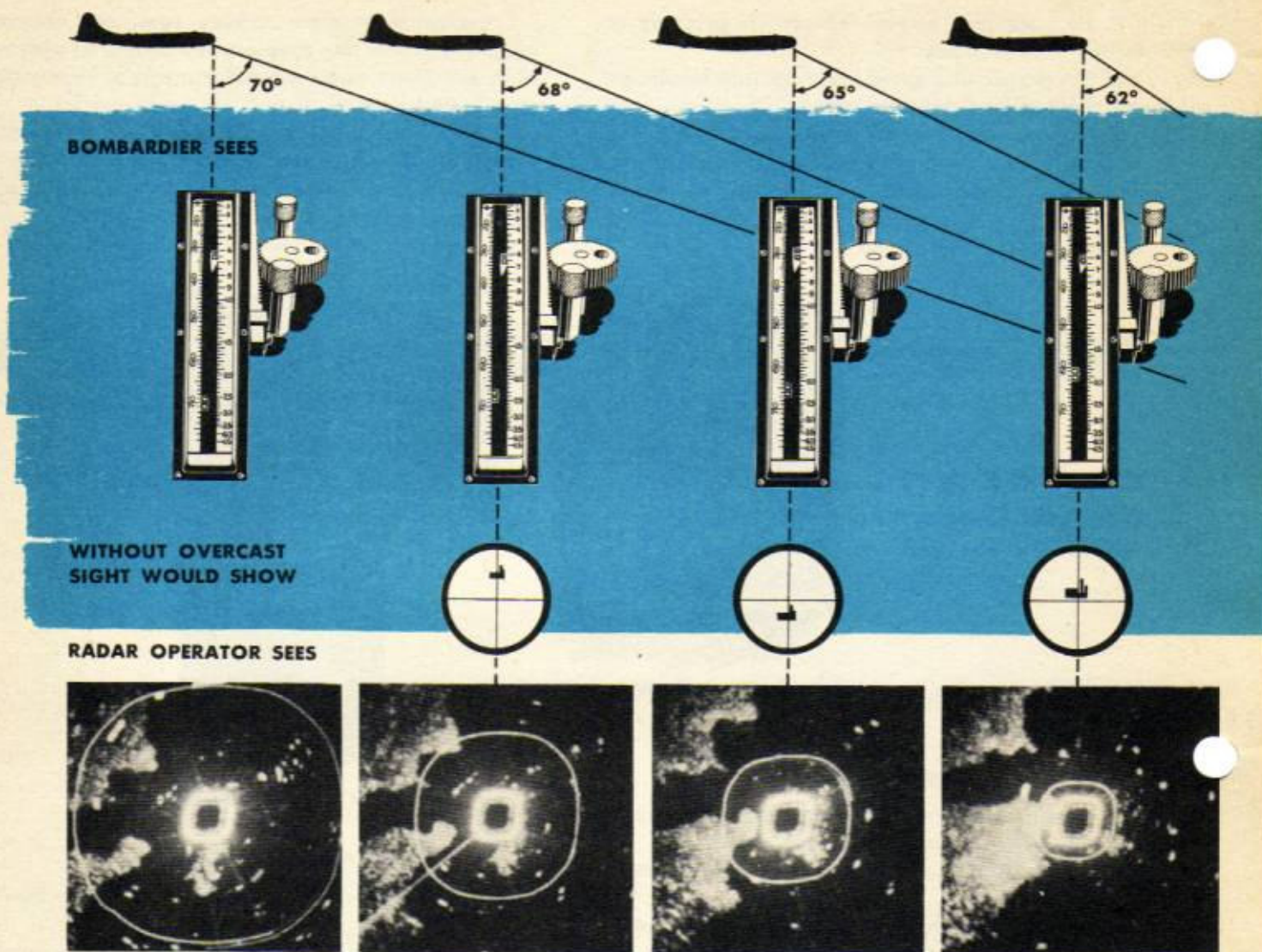

Radar, radar equipment, and details of operating procedures are discussed here only to the extent that they are related to the bombardier's part in synchronous bombing. With a thorough understanding of this technique, accurate synchronous bombing through overcast (BTO) becomes possible.

The use of radar equipment in conjunction with the M-series bombsight improves the accuracy of synchronous bombing under all weather conditions. Precision bombing has been confined more or less to daylight missions in fair weather, since the accuracy of bombing done with the bombsight alone depends to a great degree on visibility. When you bomb with radar equipment, visibility does not affect accuracy. Radar equipment, however, lacks the precision of the bombsight. Therefore, you ob-

tain the best accuracy under all conditions by using both radar equipment and the bombsight.

Synchronous bombing through overcast (BTO) by coordinated use of radar and bombsight is usually done on night missions or on day missions when visibility is poor. Experience has shown that visual bombing missions improve when they are led by an airplane which employs this BTO combination. With the advance information he receives from the radar operator, the bombardier is less likely to make any large errors.

The effectiveness of the BTO combination depends primarily on the visibility at the target. When visibility is zero, the bombardier depends entirely upon the information he obtains from the radar operator to solve the bombing problem. As visibility

BOMBING THROUGH OVERCAST

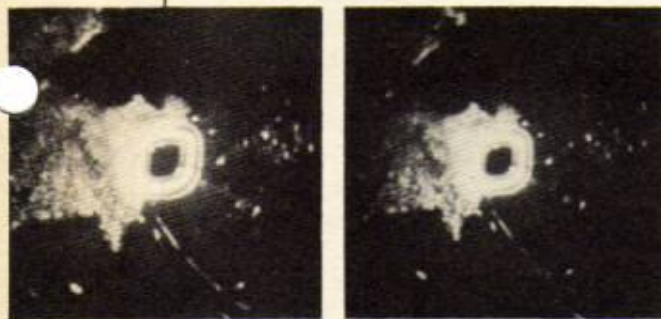
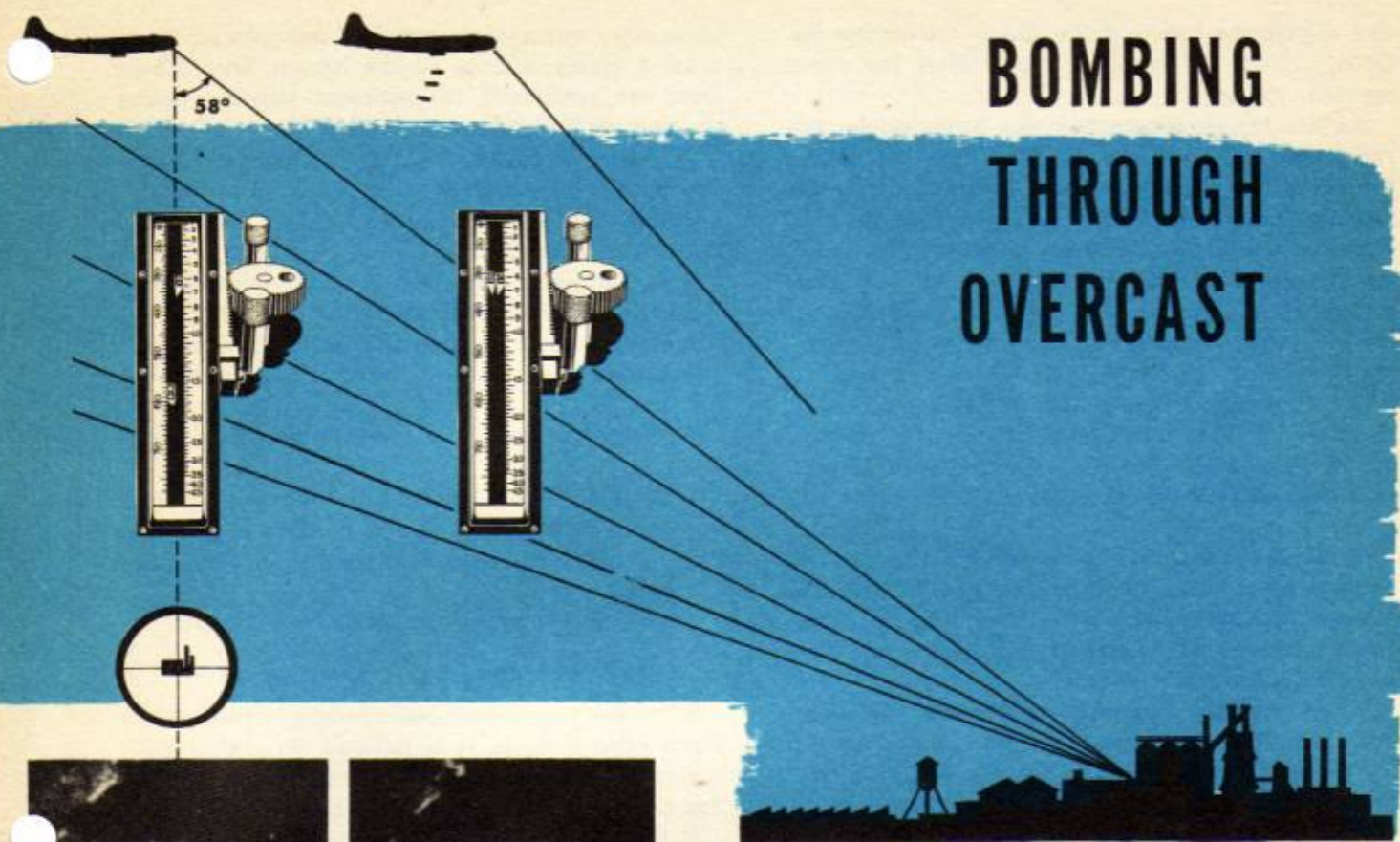

This is what happens when you do synchronous bombing through overcast. Bombing errors and corrections shown here are exaggerated.

improves, the bombardier takes over more of the sighting operation. In clear weather, bombing is done essentially by the bombsight, though with the effective aid of the radar equipment.

When range and course are determined solely with radar equipment, the operator determines the bomb release line by setting BA and GS into his set. This causes a circle to appear in the center of the scope. The scope gives him a map-like presentation of the area over which he is flying. The airplane's position is always the center of the scope. When the target appears directly under the bomb release circle the radar operator toggles or salvoes the bomb load.

In bombing through overcast, you cooperate with the radar operator in the following manner:

Course

The radar operator, using the AN/APS-15 or similar equipment, normally sets up the course to the target. He informs you of the Drift \angle . With the autopilot clutch engaged and the bombsight clutch disengaged, you set this Drift \angle on the bombsight.

Rate

The radar operator adjusts his set to position the bomb circle for a Sight \angle of 70° . Thus, when the target image appears under the bomb circle, the airplane is at a Sight \angle of 70° with the target.

With the proper DS and trail set into the bombsight, you set the sighting angle index at 70° , the dropping angle index at the predetermined Drop \angle

and engage the mirror drive clutch. Determine the Drop \angle from the bombing tables after the radar operator has given you the GS.

As the target approaches the bomb circle, the radar operator notifies you, "Ready on 70°". When the target is directly under the bomb circle, the radar operator calls "Mark" and you turn the rate motor switch ON. The radar operator adjusts his set for the next Sight \angle and once more notifies you when the target is directly under the bomb circle. This procedure is repeated for each succeeding Sight \angle . As each subsequent Sight \angle is reached and announced by the radar operator, you check the sighting angle index. If it has not traveled the correct distance, adjust it with the displacement knob and make small correction with the rate knob when necessary.

By close coordination the bombsight thus is synchronized for range. Since the radar operator also follows through on the bombing run and maintains course, he can toggle out the bombs in the event of a bombsight malfunction.

When visibility permits, you notify the radar operator, "I see it," and take over the complete control of the bombing run. You check the Drift \angle the radar operator previously gave you and set it on the bombsight, engage the bombsight clutch, and disengage the autopilot clutch. The bombsight will be nearly synchronized and only minor corrections should be needed to complete the bombing run.

Procedure on A-2 Trainer

The principles of coordination of BTO can be taught on the A-2 bombing trainer. The only thing



Horizontal lines represent sighting angles.

necessary, other than standard equipment, is to draw a series of lines on the hangar floor. These lines are positioned to represent sighting angles starting at 70° and running to 40°.

1. Set up bombsight and trainer in usual manner, except that you cage gyro and set trail arm at 0.
2. Set sighting angle index at 70° and engage mirror drive clutch.
3. Set dropping angle index at approximate Drop \angle for simulated BA and GS.
4. Instructor or another student observes marker solenoid and calls "Mark" when it is directly over 70° line.
5. When you hear this, turn rate motor switch ON.
6. As each Sight \angle is called off, check the sighting angle index. If it does not coincide with the Sight \angle announced, adjust it and make a small rate correction.
7. Repeat this procedure until bomb release.

Procedure on Supersonic Trainer

Since the target disappears before it reaches the bomb release circle, it is difficult to bomb on the supersonic trainer. However, you should practice the trainer procedure for coordinated bombing.

1. Before bombing run, trainer instructor sets bomb hit timer for ATF to be used.
 2. Before turn at IP, pre-set drift and Drop \angle computed from latest wind radar operator obtains.
 3. Set up bombsight just as you would for visual bombing.
 4. Before target reaches bomb circle set for 70°, radar operator sets up course, gives you heading and Drift \angle , and notifies you, "Ready on 70°". Pre-set drift and Drop \angle into bombsight.
 5. When target is directly under bomb circle set for 70°, radar operator calls "Mark". Turn rate motor switch ON.
 6. After he has called "Mark" for 70°, radar operator sets bomb circle for 68°.
 7. Then, when target comes under bomb circle for 68°, radar operator calls "Mark" for 68°. This is repeated until target disappears (at about 57°).
 8. When sighting angle index reaches 0°, instructor stops trainer. A few seconds later pen is raised to the paper, indicating bomb hit.
- If available, students should use scope photographs with aiming points marked. In scoring, instructor uses the mark on the top map, which is aligned with the bottom tank map, to indicate the position of the aiming point. In scoring hits, each $\frac{1}{64}$ inch equals 260 feet.



SECTION

9

EMERGENCIES AND PRECAUTIONS . . .

It is not enough to master the exacting details of successful bombing. To be of maximum value to an airplane's crew you must know how to keep yourself physically fit to endure bone-wearying flights without dangerous loss of efficiency. You must know how to give first aid to wounded crew members, recognize the hazards of high altitude, know when and how to use oxygen, what to do if the airplane's oxygen equipment fails. You must know how to improve your vision for bombing at night, how to fight fires in flight. A confident knowledge of emergency equipment and how to use it is vital if you have to bail out or the pilot must ditch your bomber. You should know how to signal for help after a crash landing. In this global war, you also need to learn how to be healthy and strong in any kind of climate.



Your airplane is a good first-aid station. You have the Kit, First-Aid, Aeronautic, and the Packet, First-Aid, Parachute. Oxygen is frequently available. Splints, or splint materials, are at hand. Hot drinks are often carried in thermos jugs. In certain bombers you will be provided with blood plasma. Familiarize yourself thoroughly with the first-aid supplies which you carry, and get clearly in mind just what you can do with them.

Wounds and Injuries

Wounds and injuries involve one or more of these problems: **pain, cuts, bleeding, broken bones, burns, frostbite, shock, and unconsciousness.** Generally you will have to deal with combinations of these, such as cuts which are bleeding, burns that cause pain, broken bones associated with cuts or burns, and so on. Shock usually comes on after a good deal of blood has been lost either inside the body (where you may not be able to see it), or on the outside. Shock also accompanies deep or extensive burns. Unconsciousness may be produced by a head injury, may follow shock, or may occur as a result of failure to get enough oxygen.

In giving first aid, try to size up the general situation accurately. Then attend to the most serious problems first. Above all, use common sense.

Cuts and Bleeding

1. Expose wound by cutting nearby clothing with scissors.
2. Cover cuts with sterile dressings and apply firm pressure.
3. If this does not stop the bleeding, elevate the bleeding part.
4. If these measures fail to stop bleeding in arms or legs, apply a tourniquet in the middle of the upper arm or middle of the thigh. The tourniquet must be released every 15 minutes for at least a few seconds, depending upon the amount of bleeding.

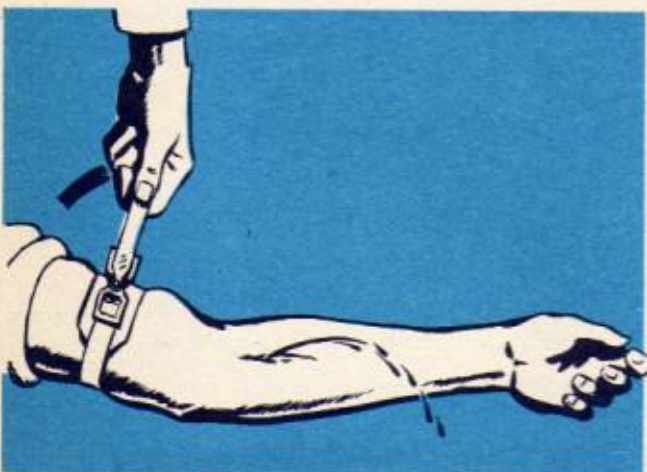

Tourniquet (Warning)

A tourniquet must be removed, or temporarily released, every 15 minutes. Failure to release the tourniquet often enough or long enough to provide an adequate circulation to the blocked portion of the arm or leg may necessitate amputation later.

Pain

Use morphine at once for severe pain. This makes it possible for the patient to lie quietly, preventing aggravation of the injuries. Do not use more than one tube ($\frac{1}{2}$ grain) of morphine at any one time.

When giving morphine, mark down the time and dose on the patient's forehead or clothing with a pencil. Remember that an excess of morphine can be fatal. Do not give morphine to a person who is unconscious, who has a head injury, or who is breathing less than 12 times per minute.

To Give Morphine

1. Paint any small area of skin with iodine.
2. Remove the transparent cover from the morphine syrette.
3. Push in the wire loop to puncture the inner seal; then pull the wire out.
4. Thrust the needle through the skin, using care not to press morphine out of the tube while doing so.
5. Squeeze the tube slowly to inject the morphine.

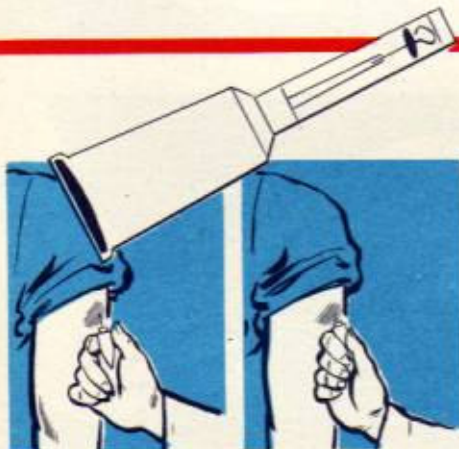

Give Morphine:

1. To stop pain.
2. To decrease shock.
3. To facilitate moving the patient.

Don't Give Morphine:

1. To an unconscious person.
2. To a person with a head injury.
3. To a person who is breathing less than 12 times per minute.

Shock

You can tell when a patient is in shock by the total picture he presents rather than by any single sign. Usually he will have:

1. Lost considerable blood, or
2. Suffered severe burns, or
3. Been subjected to intense pain, or
4. Received a head injury.

His skin is pale, cold, clammy, or moist.

His breathing is shallow, and may be irregular.

His pulse is weak, rapid, thready, and often difficult to find.

Sometimes there is nausea and vomiting.

Treat shock by doing the following things as promptly as possible:

1. Stop any obvious bleeding.
2. Give pure oxygen to breathe. (Auto-Mix OFF)
3. Give morphine. (Exception: Head injury)
4. Keep the patient warm with blankets, extra clothing, or a sleeping bag, but avoid excessive heat.
5. Loosen any tight clothing.
6. Place the patient with his head slightly lower



than his feet, to promote better circulation to the brain.

7. Inject plasma, when it is available, in accordance with the directions on the plasma package.

Fractures

1. If a broken bone is associated with a cut, sprinkle with sulfa powder and cover with a sterile dressing. If the dressing is firmly bound in place it will almost always stop the bleeding.

2. Give morphine.

3. Apply a temporary splint to the part, using wood, strips of metal, heavy cardboard, or any convenient pieces of equipment such as a machine gun barrel or fire ax.

4. Do not attempt to set the bone. Manipulation causes shock.

Burns

For minor burns:

Squeeze burn ointment onto a sterile dressing. Then cover the burn gently with the dressing.

For severe burns:

1. Give morphine.

2. Treat shock. (Oxygen; plasma, if available)

3. Apply burn ointment on sterile dressings, and bind the dressings gently but firmly in place.

4. Never open blisters resulting from burns.

For eye burns

Apply Metaphen ophthalmic ointment directly to the eyeball. Then apply the boric acid ointment to the inner surface of the eyelid. Cover the eye with a dressing and secure in place with adhesive strips, provided the skin around the eye is not burned. Do not touch the eye with your fingers, and do not rub it—either before or after the ointment has been applied.

Transportation of Wounded

If it becomes necessary to move an injured crew member improvise a litter with 2 poles and a pair of flying jackets. Turn the sleeves inside out and insert the poles through them. Then close the jacket over the outside of the poles. Additional support can be obtained by using boards or cardboard splints inside the jackets. Litters can also be improvised with poles and blankets. Take great care to be as gentle as possible in moving an injured person onto a litter. Keep his body as flat as possible at all times. Have 3 or more persons move and support him by placing their arms under his legs, buttocks, back, shoulders, and head.

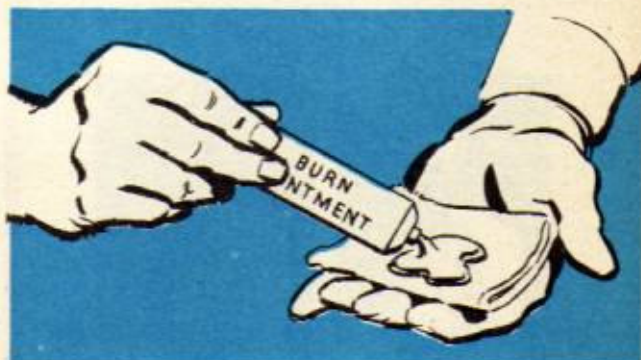



Unconsciousness and Near-Unconsciousness

Oxygen lack, carbon monoxide poisoning, and head injury are important causes. Immediate treatment is vital, especially if breathing has stopped.

1. Give artificial respiration:

First, lay the patient face down with one arm bent at the elbow, his face resting on his hand, and his other arm extended beyond his head.

Second, open his mouth and remove all foreign substances such as false teeth and chewing gum. If his tongue has fallen back into his mouth, grasp it with your fingers and pull it well forward.

Third, give him pure oxygen (Auto-Mix OFF) If the patient has stopped breathing, turn on the emergency flow.

Fourth, kneel astride the patient's thighs with your knees about even with his. Place the palms of your hands against the small of the patient's back, with your little finger over the lowest rib.

Fifth, with your arms stiff, swing your body forward slowly so that your weight is applied over the patient's back. This should take about 3 seconds.

Sixth, release your hands with a sudden snap and swing backward to remove all pressure from the patient. After about 2 seconds repeat the cycle.

Continue giving artificial respiration without stopping for 2 hours or longer, unless the person to whom it is being given begins to breathe normally.

2. Keep the patient warm.
3. Do not give morphine.

Frostbite

1. Fingers, toes, ears, cheeks, chin, and nose are the parts most frequently affected.
2. Numbness, stiffness, and whitish discoloration are the first symptoms.

3. Wrinkle your face to find out if it is numb; watch for blanched faces of your crew mates.

4. If frostbite occurs, warm the affected part gradually. Never rub or attempt to thaw it rapidly.

5. If blisters develop, do not open them.

Failure of Oxygen Supply

If a crew member's oxygen supply fails above 10,000 feet, make every effort to replace his equipment or give him an emergency supply. If this is not practicable, notify pilot. He will descend to 10,000 feet as fast as safe operation permits. Loss of oxygen above 20,000 feet is critical, but there is no need for panic. Get oxygen, or get down.



Wound Disinfectants

1. Sprinkle Sulfa powder in open wounds.
2. Use iodine only for small cuts and scratches, which should not be covered by a dressing.
3. Never put iodine on or into large or deep wounds.



FIRST AID KITS

CONTENTS

OUTSIDE PACKET

Iodine swabs, (1 package)
Bandages, gauze, adhesive, 1 pack

LARGE COMPARTMENT

Dressings, first-aid, large (2)
Dressing, first-aid, small (1)
Bandage, gauze, compress (1)
Morphine Tartrate, ½ gr., 2 tubes
Water Purification Tablets,
halazone, 1 bottle
Scissors, 1 pair
Burn-Injury Set, boric acid
ointment (1)
Eye-Dressing Set (1)
Sulfanilamide Crystals, 5 gram,
5 envelopes
Sulfadiazine, 0.5 grm., 8 tablets
Tourniquet (1)

The Kit, First-Aid, Aeronautic is a standard unit in all military aircraft (Medical Department Supply

Catalog No. 9776500). It is designed for use of air crews and should not be opened by ground personnel unless there is urgent need. The contents of the main compartment are protected by a sealed zipper. Break the seal only when you need the contents of the inner kit for the treatment of injuries. A small packet on the outside of the kit contains iodine swabs and adhesive bandages for the treatment of minor injuries. When the seal has been broken, notify your Personal Equipment Officer or Medical Supply Officer, so that he can check the contents and replace missing items. Keep your kit intact. Make sure it is sealed. Your life may depend upon it.

KIT, FIRST-AID, FOR PNEUMATIC LIFE RAFT

Medical Supply Catalog No. 9776900

This is a part of the life raft kit (See BIF 9-17-2). It contains morphine syrettes, bandage compresses, sulfanilamide powder, sulfadiazine tablets, and burn ointment.

PACKET, FIRST-AID, PARACHUTE

Medical Supply Catalog No. 9778500

To be attached to the parachute harness or Mae West life vest for constant availability. Should be carried in gun turrets and other cramped spaces where the larger Kit, First-Aid, Aeronautic is not accessible. Contains tourniquet, morphine, wound dressing, 8 sulfadiazine tablets, and 5 envelopes of sulfanilamide crystals. You can open the packet by tearing either end of the outer container at the notch.

PHYSICAL FITNESS

Good food, sufficient sleep, rest, and relaxation are important to the maintenance of physical fitness. Regular exercise, every day if possible, is essential.

Make an effort to join your crew in a regular athletic program. Touch football, basketball, soccer, speedball, volleyball, softball, and baseball are excellent forms of athletics which stimulate teamwork as well as provide necessary exercise. If you can't round up enough men for these games, play badminton, tennis, handball, squash, or medicine ball. If you are alone, keep in condition by swimming,

weight-lifting, rope-skipping, cross-country running, or any of the calisthenics or setting-up exercises you learned during your training period.

The important things are to exercise regularly and to get the most fun and relaxation when you do. Check up on your physical fitness from time to time by giving yourself the work-out prescribed in the AAF Physical Fitness Test. The test is simple, practical, and specific. You and your crew can find out how close you are to top physical condition by comparing yourselves with the standards.

During Flight

Your body becomes tired and you are less alert after remaining in one position for several hours during flight. A few simple exercises, done periodically, will break the monotony, help relieve that tense, aching feeling, and keep you more relaxed. On long flights, do these exercises every hour.



NECK: Move head backward, squeezing muscles back of neck—Hold it—Relax.

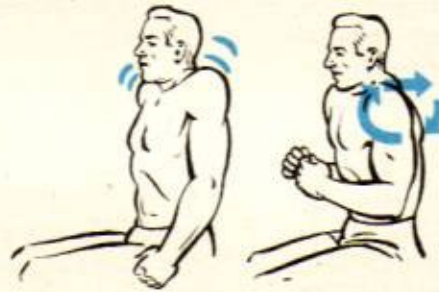

SHOULDERS: Shrug shoulders—Hold it—Let go. Now move shoulders forward, up, back—Hold it—Let go.



BACK: Arch back—Hold—Let go.



ARMS, ABDOMEN, AND BUTTOCKS: Clench fists and tighten muscles of buttocks, pressing lower back against back support—Hold it—Let go.



LEGS: Tighten leg and thigh muscles—Hold it—Relax. Now move knees close together—Hold it—Relax.

Take time for exercise daily. Good physical condition is essential to combat efficiency. It increases your resistance to anoxia, the bends, cold, and blackout, and betters your chances for survival under emergency conditions.

EFFECTS OF HIGH ALTITUDE



When you ascend into the atmosphere the air pressure drops. The higher you go the less dense the atmosphere becomes. At 18,000 feet the pressure is only 7½ pounds per square inch, or one-half of what it is at sea level. With increasing altitude the air also gets colder, up to 35,000 feet. Decrease in pressure on the body results in:

- Oxygen want (Anoxia)
- Expansion of trapped gases
- Decompression sickness

Oxygen Want (Anoxia)

The air we breathe always contains the same proportion of oxygen—21%. When the air pressure drops, however, the oxygen pressure drops correspondingly. Oxygen pressure is necessary for maintaining the proper amount of oxygen in the blood. At sea level, the pressure is sufficient to keep the blood at least 95% saturated with oxygen. This degree of saturation is necessary for peak mental and physical efficiency. When the percentage of oxygen in the blood drops, your efficiency falls off. This condition is known as anoxia or oxygen want.

In flight, oxygen want begins to affect you at altitudes above 5000 feet. It does not seriously affect efficiency, however, below 10,000 feet, except at night or on long flights. Its effect is so gradual you may not notice it. In fact, you usually feel exceptionally good in the early stages. This is one of the things that makes oxygen want so dangerous.

Unless the deficiency in oxygen is made up, your mind becomes dull; your memory, judgment, and muscular control grow worse and worse; vision and hearing are poor. Fatigue and sleepiness set in; you may have fits of laughing and crying; and finally unconsciousness and even death may occur. Above 20,000 feet anoxia causes most people to lose consciousness within a short time.

The higher you fly, the longer you stay, the more you exert yourself, the more likely you are to suffer anoxia, unless you are wearing your oxygen mask.

The only way to avoid oxygen want, unless your cabin is pressurized, is to use your oxygen equip-

ment on all flights above 10,000 feet. On all flights of 4 hours or longer use oxygen above 8000 feet. Don't depend on your feelings. You can't rely on them to tell you when you need oxygen. Regulations require using oxygen any time you fly above an **indicated altitude of 10,000 feet above sea level**. This may not agree with the reading of your altimeter if you have set it to zero for a given field.

If you ever suffer from oxygen want, see your Flight Surgeon immediately afterward.

On night flights you should use oxygen (Auto-Mix ON or NORMAL OXYGEN) from the ground up. This helps improve your night vision. (See BIF 9-11-1)

Expansion of Trapped Gases

Expansion of body gases occurs in the stomach, intestines, sinuses, and middle ear with increasing altitude. As the outside pressure decreases, these gases tend to increase in volume and cause pain when they can't be released.

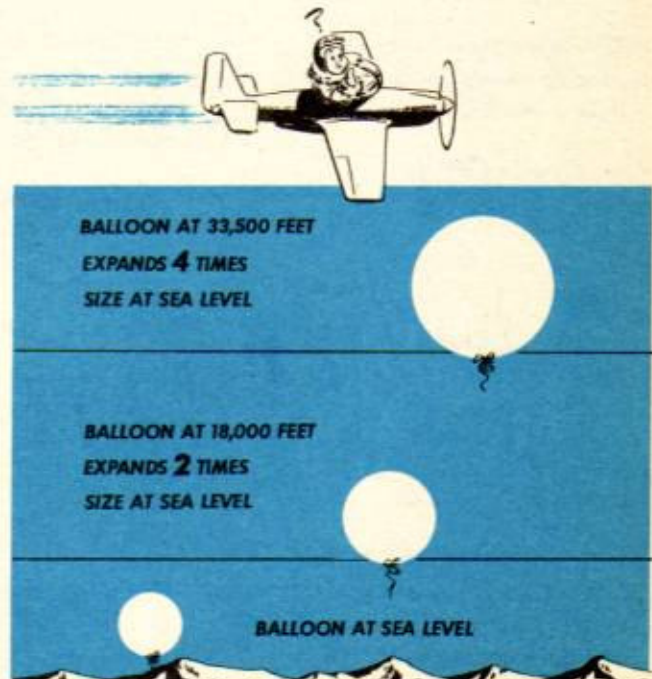

The volume of gas in the stomach and intestines tends to expand these organs like a balloon, and may cause cramps when you ascend to high altitudes. You can obtain relief by belching or passing wind. Otherwise it may be necessary to descend to a lower altitude. Gas troubles can be controlled, at least partially. When you are flying frequently, avoid gas producing food such as beans, cabbage, and carbonated beverages. Remember what foods give you trouble in flight and avoid them. Don't chew gum before or during high altitude flights. You swallow too much air when you chew.

The Ears

The sinuses and middle ear are bony spaces in the head which contain air. These spaces have a moist lining like the nose and mouth. Ordinarily air leaves and enters the sinuses easily by way of small openings into the nose as you ascend and descend. As the air in the middle ear expands it pushes on the ear

drum and makes your ear feel full. At intervals while you are gaining altitude the air slips out of the middle ear through a slit-like opening called the Eustachian tube. Each time this opens you hear a click and the pressure is equalized. During descent, however, you must make an effort to clear your ears. You can do this by swallowing, yawning, or pinching your nose and blowing gently with your mouth shut. This lets the air back in and equalizes the pressure. Practice clearing your ears. If you do this, it will increase the rate of descent you can stand comfortably.

When you have a cold the linings of the sinuses and the Eustachian tube are swollen. It may then be difficult or impossible to clear your ears, and you may suffer great pain as you lose altitude. Your ear drums may even rupture. Pressure changes in the sinuses are also painful. Therefore don't fly when you have a cold, unless it is absolutely necessary. If you have to fly, see your Flight Surgeon first.

INSIDE THE MIDDLE EAR



During a climb air leaves the middle ear with comparative ease. During descent you must clear your ears to equalize the pressure; otherwise your eardrums stretch. That's what makes them hurt.

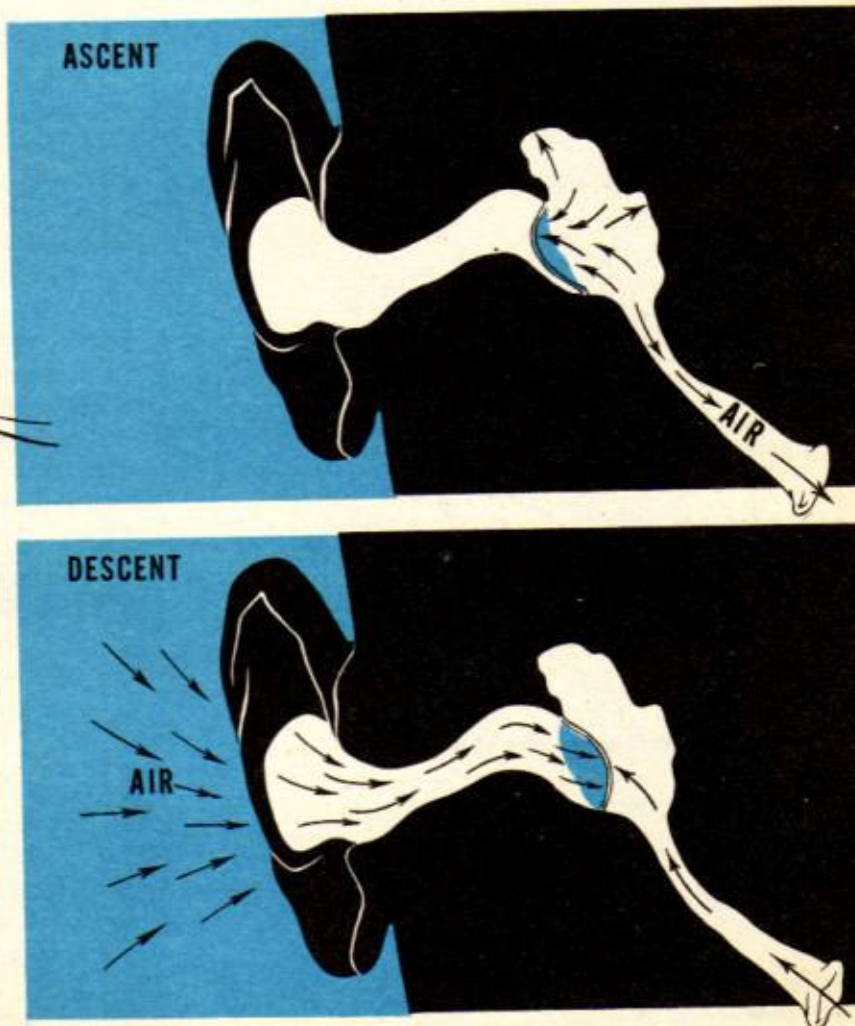

ASCENT TO 25,000 FEET WITHOUT OXYGEN

A sample of normal hand-writing in flight at 2500 ft

Control specimen of normal handwriting.

10000 ft - breathless

No apparent effect.

15000 ft - feel uneasy generally
punch feeling some numbness
in leg and hands

Beginning muscular incoordination.

18000 ft - very bad

Definite physical and mental inefficiency.

20000 ft - faint - numbness
in leg - vision fading

Last zero off both 18,000 and 20,000—marked incoordination.

22000 ft - paid on road -
bushy pale to me feel better

Feeling better? Evidence of false feeling of well-being.

23000 ft - feel good except
for leg numbness and overall
numbness

Feel good. Insight, judgment and coordination exceedingly faulty.

24000 ft - very faint
mouth a x

Mental and physical helplessness.

25000 ft - tax you turned on

Improvement with few breaths of oxygen.

3600 ft - heavy load
lighter - hearing returning
feet & N. nose -

Last zero left off—general improvement, but not completely normal.

Be sure that your oxygen equipment is functioning perfectly, that you know how to use it, that your mask fits properly, and that you know what to do in an emergency. Sudden removal of your oxygen supply at 30,000 feet will produce great mental and physical inefficiency in 30 to 60 seconds and unconsciousness in 30 to 90 seconds.

See your Personal Equipment Officer for proper operation of your oxygen equipment.

Decompression Sickness

Not only do body gases expand when atmospheric pressure decreases, but nitrogen gas in solution in the body tissues tends to escape and form bubbles. This reaction is similar to what happens when you take the cap off a bottle of soda. The pain and discomfort which result are known as **decompression sickness or aeroembolism**.

Trouble seldom develops below 30,000 feet. However, you're more likely to get it the higher you go above this altitude, the longer you stay there, the faster you climb, and the more you exercise. Then the nitrogen in your body forms bubbles, which frequently appear about the joints and in the tissues. Pain results. This condition is called **the bends**. Sometimes a feeling of weight on your chest occurs, together with tightness and pain when breathing. This is known as **the chokes**. Your skin may feel irritated and begin to itch. This is called **the creeps**.

All of these conditions are relieved by descent to 20,000 feet or lower. If you ever have them, see your Flight Surgeon as soon as possible.

Five Golden Rules for Oxygen

1. Use oxygen for all flights above 10,000 feet.
2. Use oxygen from ground up on all night flights.
3. Use oxygen on all flights above 8000 feet if in excess of 4 hours.
4. Judge your need for oxygen by your altimeter: don't rely on your sensations.
5. Check all oxygen matters with your Personal Equipment Officer.

OXYGEN EQUIPMENT

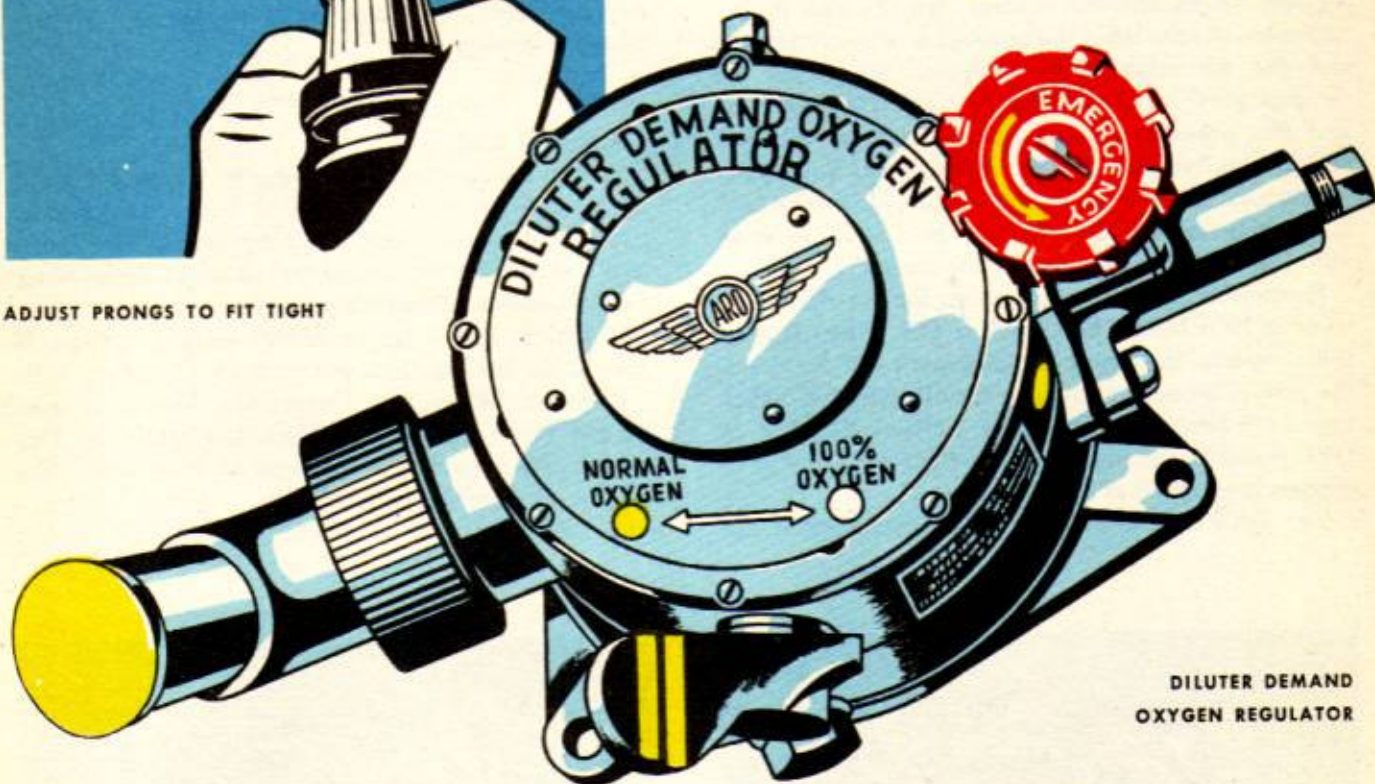

ADJUST PRONGS TO FIT TIGHT

DILUTER DEMAND
OXYGEN REGULATOR

General—Oxygen Systems

Oxygen systems are of two general types:

1. Demand System.
2. Continuous Flow System.

The demand system is automatic. It furnishes oxygen only when you breathe and in just the right amount at each altitude. Every time you draw a breath, oxygen is supplied with the proper mixture of air. All combat aircraft have demand oxygen equipment.

The continuous flow system supplies oxygen in a constant flow. To insure delivery of the proper mixture for each altitude, you must adjust a dial manually on the A-9A regulator to correspond with the altimeter reading. The A-11 regulator, used for passengers, is automatic.

Demand System

The demand oxygen system includes a demand type mask, diluter-demand regulator, pressure gage, and ball or blinker type flow indicator. In addition, a portable recharger hose is supplied at each crew position in heavy bombardment aircraft for recharging portable (walk-around) oxygen equipment from the oxygen system of the airplane.

Two types of demand oxygen masks are available—Type A-10A and Type A-14. They are used with the demand type regulators, the A-12 or AN-6004-1 regulator for permanent installations within the airplane, and the A-13 or A-15 regulator for portable use. The demand regulator is essentially a diaphragm-operated flow valve which opens by suction when you inhale and closes when you exhale. Types A-12 and AN-6004-1 are provided with two manual controls for use under special conditions—

the Auto-Mix or oxygen control lever, and the Emergency Valve.

With the Auto-Mix lever in the NORMAL OXYGEN or ON position, the A-12 and AN-6004-1 diluter-demand regulators automatically mix just the right amount of oxygen with the air for the altitude at which the plane is flying. This is accomplished by an aneroid control like the one in the altimeter. At sea level the aneroid is fully contracted and the air intake port is wide open while the oxygen port is closed. As the altitude increases and the pressure decreases, the aneroid expands and gradually closes the air intake port. Finally, at an altitude of 30,000 to 34,000 feet the air intake port is entirely closed. The oxygen port is wide open and delivers pure oxygen to the mask.

Remember, the normal position for the Auto-Mix lever is NORMAL OXYGEN or ON. When it is in that position the regulator automatically furnishes the proper amount of oxygen for all altitudes. When the Auto-Mix lever is in the 100% OXYGEN or OFF position, the air intake port is closed and pure oxygen is supplied at all altitudes.

The Type A-15 regulator, for portable use, is not

provided with an Auto-Mix lever; the mixing of air and oxygen is entirely automatic.

When the red Emergency Valve knob on the regulator is turned on, the oxygen by-passes the demand mechanism in the regulator and enters the mask in a steady flow, regardless of breathing and of altitude. This valve, therefore, should not be opened except in emergency, as the oxygen supply will be exhausted quickly.

Precautions

Preflight Check:

1. Make sure mask fits properly. Check for leaks by holding thumb over end of hose and inhaling gently. Have your Personal Equipment Officer check size and fit with his special test set or Demand Mask Leak Detector, whenever possible.

2. Check the pressure of the oxygen system. It should not be less than 400 pounds per square inch.

Caution: When the Emergency Valve is open do not pinch the hose or block the outlet, for this causes the regulator diaphragm to blow out. Then be sure to close the valve tightly.

3. Check knurled collar and hose at outlet end of



A-14 DEMAND MASK



A-10A DEMAND MASK

regulator. They should be tight.

4. Check rapid-disconnect fitting on mask hose. Be sure rubber gasket is in place. Make sure male end of fitting fits tightly into the regulator hose. It should withstand a pull of 10 to 20 pounds. Your tubing may have the C-ring type disconnect; if so, check it the same way.

5. Clip oxygen-supply hose to clothing or parachute harness so that it allows movement of head without kinking or pulling the hose.

6. Be sure the Auto-Mix lever is in the **NORMAL OXYGEN** or **ON** position.

7. Turn Emergency Valve off tight.

In the Air:

1. Check the mask as soon as you put it on, by holding thumb on end of hose and inhaling gently.

2. Manipulate the mask at frequent intervals when the temperature is low, to free it of any ice that may form. Some masks have rubber flap (inhalation baffle) inside to prevent accumulation of moisture in oxygen inlet ports. **Know how to handle your mask if it freezes. Your life depends on it.** If possible, obtain a mask heater or carry an extra mask. See your Personal Equipment Officer.

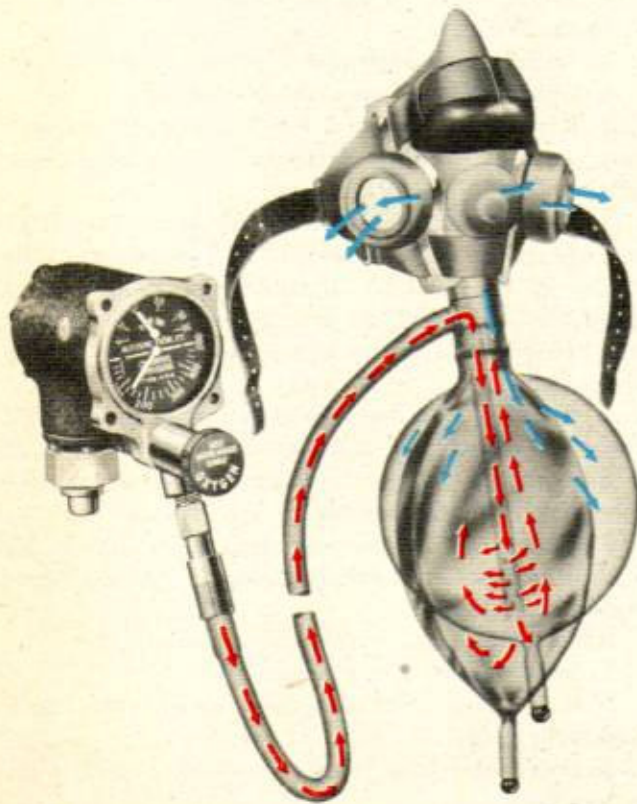

A-9A CONTINUOUS
FLOW REGULATOR

A-8B OXYGEN MASK

Use the Auto-Mix lever in the **OFF** or **100% OXYGEN** position only:

For the treatment of shock or hemorrhage, at any altitude.

For protection against fumes.

For protection against the bends, if your Flight Surgeon advises breathing pure oxygen from the ground up in special cases. For symptoms of anoxia.

3. Check the oxygen pressure gage frequently. The regulator does not function properly with a pressure of less than 50 psi.

After a Flight:

Wipe the mask dry. Wash it frequently with soap and water, rinse well, and dry thoroughly. Masks with microphones should not be immersed in water; they should be wiped with a wet cloth.

Inspect mask and hose for cracks and punctures.

Don't lend your mask to anyone except in an emergency.

Continuous Flow System

Some of the older airplanes which do not operate at extremely high altitudes are still equipped with continuous flow oxygen equipment. The A-8B mask is used with the A-9A regulator in the continuous flow system.

The A-8B mask is a re-breather type. The bag helps conserve oxygen from the exhaled air. The mask contains 2 sponge-rubber disks in the turrets of the face piece. When you are exposed to freezing temperatures, squeeze the disks to free them of moisture; otherwise ice may block them.

The A-9A regulator is entirely different from the demand regulators. You get a continuous flow of oxygen by opening the valve until the needle on

Turn on Emergency Valve only:

To revive an unconscious crew member.

If regulator fails. **Watch flow indicator.**

When removing mask at altitude.

If mask slips during a pull-out.

If a hole is shot in the oxygen tube.

To Remove Mask at Altitude

1. Unhook mask on right side, but hold tightly against face.
2. Turn on Emergency flow.
3. Take 3 or 4 deep breaths.
4. Hold breath and drop mask.
5. Don't breathe outside air.
6. Replace mask and start to breathe.
7. Turn off Emergency flow.

You can repeat this procedure, if necessary, but **don't breathe outside air.**

the dial corresponds to the altimeter reading. If you adjust this valve to correspond to the altitude you always get the proper amount of oxygen. During ascent or periods of unusual activity, keep valve setting about 5000 feet higher than your altitude.

In cargo type aircraft, passengers are supplied from an automatic continuous flow system. In this system the A-11 regulator supplies oxygen for 1 to 15 passengers. Passengers are equipped with A-8B or A-7A masks.

Precautions

Maintenance:

Have rate-of-flow checked every 10 days with a ground flow check-meter.

Keep all parts free of oil, grease, and dirt.

Check entire system for leaks. Pressure should be maintained overnight with all regulators in the OFF

Warning

Be extremely cautious not to contaminate your oxygen equipment with oil, grease, or hydraulic fluid. Fire or explosion may result if even slight traces of oil or grease come in contact with oxygen under pressure.

Be sure that all lines, fittings, instruments, and other parts are free of oil, grease, and other foreign matter.

NEVER USE LUBRICANTS ON ANY PART OF THE OXYGEN SYSTEM

position, if there has been no appreciable change in temperature.

Make certain that the valve adjustment knob of the regulator has enough resistance against turning to prevent it from being accidentally moved during flight. If it is loose, tighten the valve gland packing nut.

Preflight Check:

1. Check the cylinder pressure. It should show 400 pounds per square inch.

2. Open regulator flow valve wide and be sure needle registers maximum flow.

3. Make sure rubber gasket is present at end of mask hose.

4. Check connections between mask, bag, and connecting tube.

5. Make sure bayonet connection is locked.

6. Check re-breather bag for holes. Be sure plug is in bottom of bag.

7. See that exhalation disks are in place.

8. Carry extra sponge-rubber disks and protective shields for exhalation turrets or a protective fabric bag for entire mask. Take along an extra mask if you go to altitudes above 20,000 feet, in case the one you are wearing freezes.

9. Adjust mask straps for comfortable fit.

In the Air:

1. Be sure your regulator is set at proper altitude.

2. Check cylinder pressure occasionally.

3. Breathe normally. Over-breathing is dangerous; it may produce dizziness and other serious effects.

4. Put protective shields on exhalation turrets or use the fabric bag whenever the temperature falls below 10°F (-12.3°C). If shields and bag are not available, examine the sponge disks at intervals and remove any ice by squeezing them, or change the sponges.

5. Above 30,000 feet the re-breather bag should never be completely collapsed when you inhale. If it does collapse, open the valve further, no matter what the flow indicator reads.

6. After you change your station at altitude be sure the regulator is properly set and that the bayonet fitting is locked.

After a Flight:

1. Shut all flow valves tight.

2. Wash mask with soap and water, rinse well, and hang to dry.

3. Don't lend your mask to anyone except in an emergency.

4. Keep your mask in a safe place and away from sunlight.

PORTABLE OXYGEN EQUIPMENT

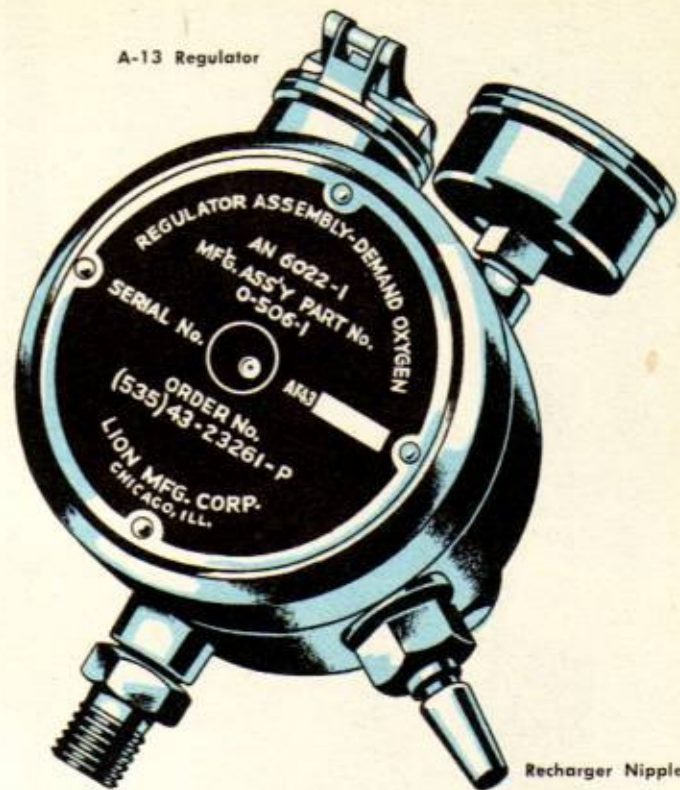

Walk-Around Bottle

Large airplanes are provided with portable oxygen equipment consisting of walk-around oxygen cylinders and regulators. This equipment allows you to walk away from your oxygen station in the plane and provides an emergency source of oxygen.

Three types of portable assemblies are in use:

1. The A-4 cylinder and A-13 regulator. Duration of supply, 3 to 8 minutes.
2. The D-2 cylinder, which has a harness for the shoulder, and A-13 regulator. Duration of supply, 20 to 50 minutes.
3. The A-6 cylinder and A-15 regulator, which has clip for attachment to the clothing or parachute harness and an Auto-Mix mechanism (but no lever). Duration of supply, 15 to 40 minutes.

The duration of supply is variable, depending upon the altitude and how much work you are doing. The only safe rule for using walk-around equipment is to watch the gage. Fill your cylinder before take-off and refill it from the plane's oxygen system whenever the pressure falls below 100 pounds per square inch.

To Use the Portable Unit

1. First check the pressure gage to make sure the pressure is at least that of the airplane's oxygen

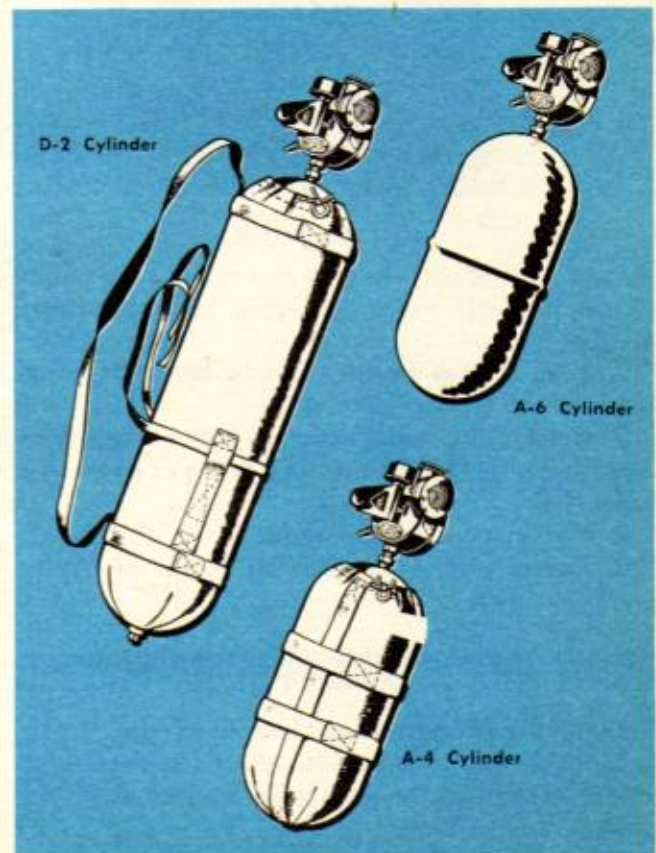



H-2 BAILOUT BOTTLE

system. If it is not, recharge the cylinder by means of the portable recharging hose at each oxygen station.

2. Take a deep breath, hold it, then disconnect mask hose from regulator hose.

3. Quickly lift spring cover on walk-around regulator and plug in tight the male fitting of your mask hose.

4. Now start to breathe again.

5. Fasten unit to yourself by means of clip or shoulder strap.

On all flights above 30,000 feet. Keep your bail-out bottle connected to your oxygen mask. This gives you most protection in an emergency.

Oxygen for Ditching

If you have to ditch, prepare for underwater escape from your plane by wearing your oxygen mask connected to your walk-around bottle and A-13 regulator. The duration of the A-4 portable cylinder is short under water, but with the D-2 portable cylinder you can breathe for about 6 minutes at a water depth of 10 feet.

6. Watch for twisting or kinking of hose.
7. **Keep bottle filled! Refill at 100 pounds!**
8. Never leave your oxygen station at high altitude without a walk-around bottle.

BAILOUT OXYGEN CYLINDERS

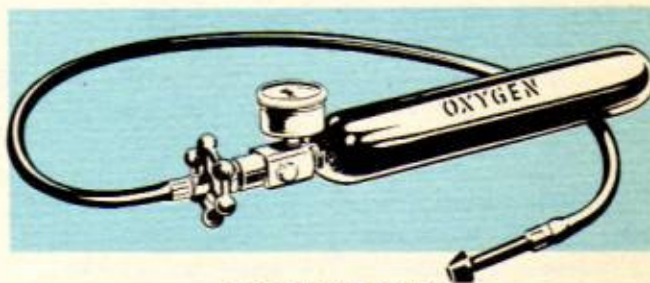

H-1 BAILOUT BOTTLE

Two bailout oxygen cylinder assemblies are available for parachute descents from high altitudes. Both are completely self-contained units with pressure gage and release valve.

Either cylinder must be tightly fitted and securely tied in a pocket sewn to the flying suit or harness.

Before takeoff, check the cylinder's pressure gage. It should read at least 1800 pounds per square inch. Either cylinder assembly can be used in parachute descents above 30,000 feet. Sometimes it is used as an emergency oxygen supply in fighter aircraft if the regular oxygen supply suddenly fails.

Type H-1: Before jumping, grip pipe stem between your teeth and completely open flow valve.

Type H-2: Before jumping, pull the release to open flow valve. Then, disconnect the main oxygen tube and tuck it inside your jacket. If this is impossible hold your left hand over the free end. Then jump, keeping free end of main oxygen tube covered until parachute opens.

PRESSURE BREATHING

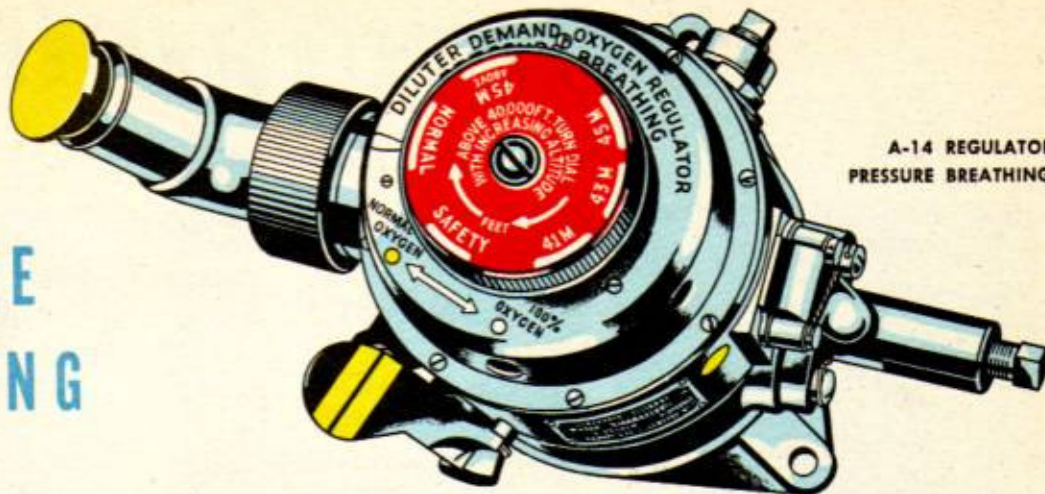

A-14 REGULATOR
PRESSURE BREATHING

Pressure demand equipment increases your safe ceiling. With it you have a greater safety factor between 30,000 feet and 40,000 feet. The extra pressure compensates for possible small leaks in your mask fit and insures your getting 100% oxygen. Breathing out against pressure takes a little effort, but you get used to it quickly.

With pressure demand equipment you can safely fly as high as 43,000 feet. In emergencies you can go even higher for brief periods.

The pressure demand oxygen system is the same as the regular demand system, except for the regulator and mask.

Pressure Demand Regulator Type A-14 is a Type AN-6004-1 diluter demand regulator to which a spring-weighted diaphragm has been added for pressure breathing.

Pressure Mask, Type A-13A or A-15, is a special one which must be used for pressure breathing. It can be used with some regular demand regulators (Aro type), but a regular demand mask cannot be used for pressure breathing.

Flow Indicator. Without pressure breathing the blinker works the same as with the regular demand system. With safety pressure or pressure breathing, the blinker may not work.

How to Use Pressure Demand Equipment

Below 30,000 Feet:

Use regulator just like regular demand regulator. It can be used with regular demand mask or with pressure breathing mask. With regular demand mask, you can obtain an emergency flow by turning the pressure dial on the regulator.

Above 30,000 Feet:

Use regulator for pressure breathing by turning dial clockwise. The regulator gives you 100% oxygen

on demand. The farther you turn the dial the greater the flow pressure of oxygen.

How to Use Dial Control

Below 30,000 feet, keep setting on **NORMAL**.

Between 30,000 feet and 40,000 feet put setting on **SAFETY**.

Between 40,000 and 41,000 feet, set dial to 41M.

Between 41,000 and 43,000 feet, set dial to 43M.

Between 43,000 and 45,000 feet, set dial to 45M.

Above 45,000 feet, set dial to 45M ABOVE.

To be safe, always have the dial setting slightly higher than the altimeter reading.

Check Your Mask Before Each Flight

1. Do a suck test, as with regular demand mask, holding thumb over end of mask tube. This tests the fit and the exhalation valve. When you inhale, the mask should be sucked in toward your face.

2. Hook up mask to regulator, turn dial up to give oxygen under pressure, and hold your breath. Oxygen should stop flowing into mask. If it keeps flowing, check mask fit and exhalation valve.

3. Now breathe with oxygen under pressure to be sure you can exhale easily. If you can't, check with your Personal Equipment Officer.

4. Clean mask periodically with a wet cloth.

REFERENCE: Technical Order No. 03-50-31

Don't use pressure breathing below 30,000 feet. It wastes oxygen. Below 30,000 feet keep Auto-Mix Lever on NORMAL OXYGEN and the dial setting on NORMAL.

OXYGEN EMERGENCIES

If crew mate is unconscious:



1. Make sure of your own oxygen supply.



2. Check his mask-to-regulator connections carefully.



3. Check his oxygen cylinder pressure.

If pressure is below 50 psi:



1. Connect his mask to walk-around bottle.



2. Keep his bottle filled from yours or from another recharger hose.



3. Check his mask for possible leaks or obstructions.

If pressure is above 50 psi:



1. Open his Emergency Valve (with pressure demand regulator, set dial on SAFETY).



2. Check his mask for any leaks or obstructions.



3. When he comes to, turn the Emergency Valve off.

If he still doesn't come to, check these points:



1. Breathing (Give artificial respiration; BIF 9-1-4).



2. Bleeding (Apply local pressure or tourniquet).



3. Can the pilot fly lower?

DANGEROUS GASES

The air you breathe while in flight should be free of all other gases except the oxygen from your mask. Exhaust gases, gasoline vapors, hydraulic fluid fumes, smoke, or poison gas may contaminate the cabin air. In sufficient concentration, any of these is dangerous. You can protect yourself from them by knowing when to suspect their presence and by observing the necessary precautions.

Exhaust Gas

Exhaust gas is a mixture of several substances. Among them are carbon monoxide and oxides of nitrogen, both of which are poisonous. In exhaust mixtures, carbon monoxide is the more important, for it is present in larger amounts. Carbon monoxide acts by combining with the red cells of the blood and making them useless for carrying oxygen to the body tissues. This results in oxygen want or anoxia. As you ascend from sea level the dangers resulting from carbon monoxide increase, even below 10,000 feet, unless you use your oxygen mask.

In Flight:

The effects of carbon monoxide poisoning are similar to those caused by oxygen lack—shortness of breath, headache, nausea, dizziness, dimming of vision, poor judgment, weakness, unconsciousness, and death. The higher the concentration of the gas, the longer you breathe it, the higher the altitude (unless you use your oxygen mask), and the greater your activity, the more severe are the symptoms.

Like anoxia, carbon monoxide poisoning may give

no warning. The gas itself has no odor, but you can be pretty sure of its presence if you smell exhaust gas. **The only safe rule for protecting yourself against carbon monoxide in flight is to wear your oxygen mask with the Auto-Mix in the OFF or 100% OXYGEN position whenever you smell exhaust gases. In this way you get pure oxygen to breathe and are completely protected from any gases in the airplane.** If you had any unpleasant sensations during flight see your Flight Surgeon as soon as possible after landing.

Don't use your exhaust heater during combat. Enemy gun fire may cause dangerous leaks of exhaust gas into the cabin.

On the Ground:

Carbon monoxide is always present in poorly ventilated hangars and garages when engines are running. Ventilate such places as much as possible. If the doors must be kept closed, don't stay inside any longer than necessary.

In cold regions, where gasoline or oil stoves and lamps are used in closed buildings or tents, carbon monoxide is formed whenever fuel is burned. Cross-ventilation is your only reliable protection.

Gasoline Vapors

Gasoline vapors in aircraft cabins may cause serious trouble. Aviation gasoline contains special compounds which make its vapors more dangerous than those of ordinary gasoline. One gallon produces 30 cubic feet of vapor at sea level. These vapors are heavier than air.

Breathing gasoline vapors is harmful because the vapors are easily absorbed by the lungs. Even one-tenth of the concentration of gasoline vapor which is necessary to support combustion is dangerous if inhaled for more than a short time. Symptoms may include dizziness, nausea, headache, burning and watering of the eyes, restlessness, excitement, disori-

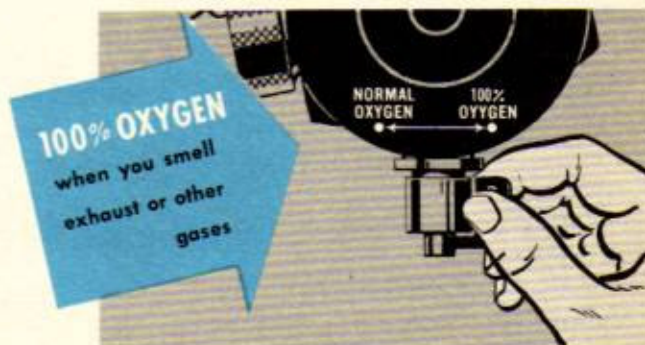

entation, disturbances of speech, vision, and hearing, convulsions, and unconsciousness.

One gallon of gasoline produces 1600 cubic feet of explosive vapor at sea level and has the blasting power of 83 pounds of dynamite.

If a gasoline leak occurs in your airplane, or if any crew member smells gasoline vapors during flight:

Leave all electrical and radio equipment switches just as they are; the slightest spark may cause an explosion.

Ventilate the cabin if possible.

Put on your oxygen mask with Auto-Mix in OFF or 100% OXYGEN position. This excludes contaminated air from the lungs.

Stop smoking; put on goggles, if available, to protect eyes from irritation; roll down sleeves and put on gloves, helmet, and other articles of clothing for protection against burns in case of fire.

Hydraulic Fluid Vapors

Some types of hydraulic fluid contain substances which are dangerous when their vapors are inhaled. They cause irritation of the eyes and breathing passages, headaches, dizziness, and disturbances of judgment and vision. These harmful effects are increased by altitude or by high temperatures. Use your oxygen mask with Auto-Mix OFF (100% OXYGEN) if hydraulic fluid leaks into the cockpit.

A spray of hydraulic fluid ignites easily and spreads its flames rapidly. Be on guard against fire if a hydraulic leak occurs.

Smoke

Smoke may arise in the airplane from a variety of sources such as hot oil fumes, a break in the coolant fluid lines, or from signal flares. Some types of smoke are dangerous to breathe, but all smoke irritates your eyes and throat and makes you cough. Don't take chances. Wear your goggles and use your oxygen mask with the Auto-Mix OFF and breathe 100% oxygen until you clear the cabin of smoke.

Poison Gas

The poison gases which were known at the end of the last war are all heavier than air and tend to collect near the ground. Most of them have a distinctive odor:

Phosgene and Di-Phosgene (Odor of musty hay or decaying leaves).

Chlorpicrin (Sweetish smell, like licorice).

Mustard gas (Smells like garlic or onion).

Lewisite (Geranium-like odor).

Accurate identification of these gases may be impossible, because of the use of mixtures or of newly developed agents. Most of them cause irritation of the eyes and lungs.

A gas mask, of course, is the ideal protection against these poisons. When a gas mask is not available, your oxygen mask, together with goggles, provides the best type of protection. But be sure to keep the Auto-Mix OFF (100% OXYGEN).

Phosgene is formed when the carbon tetrachloride in your fire extinguisher comes in contact with fire. Ventilate aircraft thoroughly after extinguishing fire, to avoid unnecessary exposure to phosgene, or protect yourself by means of gas mask or oxygen mask. (See BIF 9-12-1).

First Aid

If a man is overcome, begin first aid at once:

1. Remove him from the source of the gas.
2. Give him pure oxygen to breathe, if available (turn on emergency flow).
3. Begin artificial respiration immediately (See BIF 9-1-4).
4. Keep him warm.
5. Send for a medical officer.
6. Never exercise a person who has been overcome by gas. This only makes him worse.

References: AAF Ltr 62-9, AAF Reg. No. 55-20

SMOKING IN AIRCRAFT IS PROHIBITED

During all ground operations.

During and immediately after
takeoff.

During fuel transfer operations.

Immediately before and after
landing.

Any time any occupant detects
gas fumes.

In bomb bay or fuselage section
containing auxiliary gas tanks.

In the passenger compartment
of C-87 type aircraft at all times.

In the C-54 type aircraft when
fuselage tanks are installed.

At any time or place whenever
aircraft commander deems such
action necessary for safety.



Bombardier's flak suit has full armor. When he pulls ripcord at suit's center, entire suit falls off.

FLAK SUITS

Flak suits consist of armored vest and apron assemblies. They are not personal issue, but they should be delivered to the plane before the flight and picked up afterward for inspection. You couldn't carry one anyway, with everything else you're lugging. Report to the pilot if you don't find a flak suit in the plane for you.

Wear the suit when you approach the target area. It's heavy but it's guaranteed that you won't notice the weight when the fight begins to get hot.

Note: Ask your Personal Equipment Officer to have a tab sewed on your flak suit for your oxygen mask hose clip.



FLAK HELMETS

The flak helmet is personal issue. If you have worn both your flak suit and flak helmet on the mission, you have a good chance of returning the helmet to the supply room **personally** after the flight.

VISION AT NIGHT



Some animals see as well at night as during the day. Man cannot. But your efficiency in night flying and your effectiveness in night combat depend on your night vision. Learn how to improve it.

Night vision differs from day vision. In daylight the center of the retina, or lining of the eye, is the most sensitive part of the eye. At night, however, the center of the retina can't see at all. It is called the night blind spot. In dim light the off-center parts of the retina are most sensitive. Try it. You see best at night when you look slightly off-center or to the side of the object you wish to see. The off-center parts of the retina also detect movement more easily than does the central part.

When searching the sky, earth, or surface of the sea at night, the most effective and simplest method is scanning. Keep your line of sight fixed in one direction for about a second. Then move your eyes or head in jumps of 10° to 20° , as in reading a book, and pause for a second or two at the end of each jump. In this way you cover the entire field in a series of eye or head movements and pauses.

If you remain in a dark room your eyes gradually see things which they could not see at first. This is known as **dark adaptation**. By adapting your eyes to darkness you increase their sensitivity 10,000 times. That is, after only 30 minutes in the dark you can see a light 10,000 times dimmer than any you could have seen in bright light. You can also adapt your eyes in a light room by wearing red-lensed goggles. It takes a half-hour to adapt to dark, but you lose your adaptation temporarily by exposing your eyes to bright light for only a brief period.

The retina is highly sensitive to oxygen lack. So on all night flights, except low altitude training missions, **use oxygen from the ground up**. It pays.

Ability to see at night depends upon your body's content of Vitamin A, obtained chiefly from eggs, butter, milk, cheese, liver, carrots, squash, peas,

apricots, and peaches. Eat them liberally.

Dirt, oil, and scratches on your plexiglas windows or goggles make night vision more difficult. They scatter light and produce glare. Keep your goggles and the plexiglas nose scrupulously clean and free of scratches.

Aids to Night Vision

Adapt to the dark. Stay in a dark room or wear red-lensed goggles (Goggles, Assembly, E-1, Class 13, Stock No. 8300-331450) for a half-hour before any night operation.

Protect your adaptation. Don't expose your eyes to bright lights before takeoff or during flight, either inside or outside airplane.

Avoid lights. Keep all non-essential lights in plane turned out and dim all essential lights.

Make readings fast; then look away. Don't look too long at lighted instrument panel or charts. Or use only one eye; the other will retain its dark adaptation.

Use red light in your compartment, if possible. But remember then that red lines will not show as red on your charts.

Use oxygen from the ground up on night flights.

Keep plexiglas nose and goggles clean and free of scratches.

Avoid looking at white paper or other white objects; they reflect light.

Practice off-center glances at night.

Get enough Vitamin A. Eat the proper foods.

Don't Stare at Night

If you stare at a light in a dark room, you soon think the light has begun to move. The same thing happens when you stare at a light outside the cockpit while flying at night. Don't stare at the tail light of your lead plane when flying formation at night.

Fire Fighting

Use all extinguishers applicable and always aim at the base of the fire.

Keep your parachute away from the fire. Put it on as soon as possible.

Move to your proper position for bailout when a crash seems imminent.

Engine Fires

At the first sign of a fire, if conditions permit, the pilot will take all necessary action to control it from the cockpit. His actions depend upon the type of equipment he has.

In any engine fire your only duty is to give the pilot any useful information you have and to stand by for orders.

Flare Fires

If flares in the racks ignite, release the flares at once. Pry them loose if they stick in the racks.

Fuel Tank Fires

1. Locate source of fire.
2. Inform pilot.
3. If fire is accessible, use hand equipment in addition to the built-in equipment.

Cabin Fires

1. Give pilot and radio operator necessary information.
2. Close windows and all openings.
3. Locate source of fire.
4. Use all extinguishers available. (Open windows as soon as the flames are extinguished.)

DEATH STRIKES WITH WHIRLING BLADES

More than half a hundred persons were killed or seriously injured at Army airfields in continental United States during 1944 when they were struck by revolving propellers. One-fifth of those who died were fatally injured by walking into propellers during the excitement of leaving a burning airplane or hurrying to put out such a fire.

Don't lose your head if a fire occurs! Remember, if the airplane's engines are still running, their pro-

pellors are a far greater potential menace to you than the flames.

In nearly every case, inexcusable negligence caused these propeller accidents. Of the bombardiers who were killed, two alighted from B-24 airplanes through the bomb bay and walked into the No. 3 propeller. A third, carrying camera equipment, attempted to walk between the fuselage and the No. 3 propeller.

Other Fires

The pilot will attempt to extinguish wing fires or drop tank fires by slipping the airplane away from the fire or dropping the tanks.

Your only duty is to give the pilot whatever useful information you can provide.

In case fire occurs while the airplane is carrying bombs, at pilot's command salvo bombs. Then close bomb bay doors immediately.

In case of fire when the airplane is not carrying bombs, don't open emergency hatches or bomb bay doors in the air, except for bailout. External fires may be drawn into the cabin. Drafts will cause cabin fires to flare up.

Open emergency hatches just before landing, if fire makes a crash landing necessary, to permit escape or rescue.

On the Ground

If a fire occurs while the pilot is starting the engines:

1. Help other crew members use portable fire-fighting equipment.
2. **Notify tower to rush crash equipment.**
3. Make sure everyone has cleared the airplane.
4. Remove the bombsight.

Fire Fighting Equipment in Airplanes

LEARN THE LOCATION AND PROPER USE OF FIRE EXTINGUISHING EQUIPMENT INSTALLED IN YOUR AIRPLANE



"Fyr Fyter" hand-type fire extinguishers, having a carbon tetrachloride base, are found in most airplanes. Use this extinguisher primarily for fighting fires in the cockpit or cabin. It is unsuitable for extinguishing fires outside the fuselage during flight.

Aim at the base of the fire, remembering that your supply is limited and must be used effectively. The "Fyr Fyter" extinguisher in your plane has enough fluid to last for about one minute of continuous use. Its effective range is approximately 20 feet.

**AIM AT
BASE OF FIRE**

Know the location of all extinguishers, their limitations, and how to use them.

**AIM BEFORE
PULLING TRIGGER**

Both of these extinguishers are effective in combating fuel, electrical, and wood or fabric fires. CO₂ is rapid, clean, and easy to use. However, because of the small quantity in the cartridge, it might not be final in action.

Built-in CO₂ (carbon dioxide) systems are installed in some types of airplanes, so that engines, hulls of amphibians, gasoline tank compartments, or even cargo sections may be flooded with carbon dioxide gas in case of fire. First, set the extinguisher selector valve to direct the CO₂ charge to the desired location. Then pull the release handle. The operating controls are marked clearly to indicate their method of use.

Precautions

Stand back, but within effective range, when using the "Fyr Fyter" carbon tetrachloride extinguisher. Open windows and ventilators after fire is extinguished. The fumes generated are poi-

sonous. See a doctor as soon as you land if you have inhaled excessive amounts of the gas or have swallowed even a small quantity of the liquid.

CO₂ hand-type fire extinguishers, using carbon dioxide, also are found in large airplanes. Use this extinguisher for fighting fires inside the airplane. The CO₂ extinguisher has an effective range of only 3 feet. The charge will last only 15 to 30 seconds, according to size of the unit. So aim at the base of the fire and move in close, on the upwind side. **Then pull the trigger release, directing the CO₂ straight at the base of the fire.** Move the discharge nozzle slowly across the flame area.



sonous. See a doctor as soon as you land if you have inhaled excessive amounts of the gas or have swallowed even a small quantity of the liquid.

Don't touch any portion of the discharge nozzle of the CO₂ extinguisher. The extremely cold temperature of the carbon dioxide may cause severe burns.



Parachutes

All persons aboard Army airplanes will be equipped with standard-type parachutes. Wear your parachute whenever possible. The pilot will see that all persons aboard have parachutes, are instructed in their use, and know the bail-out plan. It is an excellent precaution to carry an extra parachute in multiplace airplanes.



**CORRECT
LANDING
POSITION**

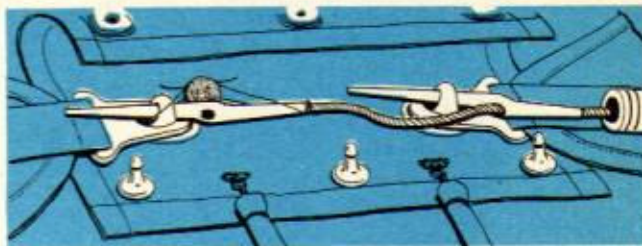

BEFORE THE FLIGHT

Inspect your parachute. Remember, you may have to jump with it! Check the date of the last inspection. The packing interval should not exceed 60 days in the United States or 30 days in the tropics. Open the flap; make sure that the ripcord pins are not bent and that the seal is not broken. A bent pin or jammed wire may make it impossible to pull the ripcord. See that the corners of the pack are neatly stowed so that none of the silk is visible. See that the six or eight opening elastics are tight. Inspect each parachute you draw.

Put your parachute on and be sure the harness fits properly. The shoulder and chest straps should be snug without play; the chest buckle should be twelve inches below the chin. The leg straps should be snug. In fact, the harness should be comfortably snug when you are seated and disagreeably tight when you stand up.

PULLING THE RIPCORD

Know which exit you are to use in an emergency, and how and when to use it. Carefully study the AAF bail-out poster for your type of airplane.

You will normally use an escape hatch, the bomb bay, or a door. Slide yourself to the edge of the opening and go out head first and straight down.

Clearing the Airplane

Probably the most important single act, in any parachute jump, is opening the parachute only **after you are clear of the airplane**. Wait until you are well away before you pull the ripcord. Keep your eyes open. Look around. If you have enough altitude, wait at least 5 to 10 seconds before pulling the ripcord.

There is nothing complicated or difficult about getting your parachute safely open. Just:

1. Straighten your legs and put your feet together to reduce the opening shock, and to avoid tangling your harness.
2. Use both hands to grasp the ripcord pocket.
3. Grab the ripcord handle with the right hand, and yank! Keep your eyes open and look at the ripcord as you pull it.

THE DESCENT

About two seconds after you have pulled the ripcord, you will feel a sharp, strong tug as the canopy opens and bites the air.

Look up to see that the chute is fully open. If a suspension line traverses the top, or the lines are twisted, manipulate the lines to remedy the fault.

Do not worry about oscillations. They will almost certainly occur on your way down, but are of minor consequence. Do not attempt to check them or to slip the parachute, as such maneuvers are useful only to experts, and are dangerous below 200 feet.

Make a quick estimate of your altitude by looking first at the ground below and then at the horizon.

You will descend about 1000 feet per minute.

Observe your drift by craning your neck forward and sighting the ground between your feet, keeping your feet parallel and using them as a driftmeter.

Face in the direction of your drift.

While you cannot steer your chute, you can turn your body in any desired direction. **The body turn is the most useful maneuver you can learn because with it you can make certain that you land facing in the direction of your drift. It is simple and easy. Note carefully exactly how it is done.**



HOW TO MAKE BODY TURNS

TO TURN YOUR BODY TO THE RIGHT:

1

Reach up behind your head with your right hand and grasp the left risers.



2

Reach across in front of your head with your left hand and grasp the other risers. Your hands are now crossed, the right hand behind, and in each you have two risers.



3

Pull simultaneously with both hands; this will cross the risers above your head and turn your body to the right. You can readily turn 45°, 90°, or 180° by varying the pull.



**To turn to the left,
reverse this procedure.**

In the descent, start your body turn high enough to allow you to master it. Once you have made the turn, you will find that you can control your direction of drift perfectly. Hold the turn, or slowly ease

up if necessary, to bring you in facing downwind. Continue to hold the risers, whether you have had to twist them to make a body turn or not, and ride right on into the ground this way.

THE LANDING



NORMAL LANDINGS

Whether you have made a body turn or not, keep your hands above your head, grasping the risers.

Look at the ground at a 45-degree angle, not straight down.

Set yourself for the landing by placing your feet together and slightly bending your knees, so that you will land on the balls of your feet.

Don't be limp; don't be rigid.

Relax, and keep your feet firmly together with your knees slightly bent, and your hands grasping the risers above. Now hold everything and ride on into the ground, drifting face forward.

At the moment of impact, fall forward or sideways in a tumbling roll to take up the shock.



High Wind

ABNORMAL LANDINGS

If there is a strong wind blowing across the ground when you land, do two things.

First, make certain that you carry out the procedures described above for a normal landing, **including the body turn to face you exactly in your direction of drift.**

Second, once you are down, roll over on your abdomen and haul in hand over hand on the suspension lines nearest the ground. Keep right on pulling them in until you grab silk. Then, drag in the skirt of the canopy to spill the air and collapse the chute. If you can't manage this maneuver on your face, go over onto your back, but haul in the suspension lines until you have got the bottom edge of the canopy, then spill the chute.



Trees

Tree landings are usually the easiest of all. If you see that you are going to come into a tree, drop the risers, cross your arms in front of your head, and bury your face in the crook of an elbow. You can see under your folded forearm. Keep your feet and knees together. If you get hung up high in a tree, consider first the possibility of immediate rescue before you try to climb down. Failing that, get out of the harness and cut the lines and risers to make a rope for climbing down.

Water landings are safe if you know what to do. The ability to swim is an advantage but not a prerequisite if you are properly equipped and trained. Follow the procedure outlined here for all types of parachutes except the QAC AN6513-1A (which has no risers on pack or harness) and the single point quick release, instructions for which are given separately. Prepare for the water landing as soon as the parachute is open.

1. Throw away what you won't need.
2. Pull yourself well back in the sling by hooking your thumbs in the webbing and forcing the sling downward along your thighs.
3. Undo your chest strap by hooking a thumb beneath one of the vertical lift webs, pushing firmly across your chest to loosen the cross webbing so that you can undo the snap. **This must be done before you inflate the Mae West, as the chest strap cannot be released over an inflated life vest.**
4. When chest strap is undone and you are well back in the sling, unsnap the leg straps by doubling up first one leg and then the other. Then keep your arms folded, or hang onto the risers, so you won't fall out of the harness. If you are unable to unfasten leg straps in the air, remove them in the water by unfastening them or by working them down over your feet.
5. As soon as you are in the water, inflate your Mae West, one half at a time (either half will support you) and shrug out of the harness. **Remember, never inflate your life vest until you have unfastened your chest strap.**
6. Get clear of the parachute promptly, and stay clear.

Procedure for QAC AN6513-1A (no risers on pack or harness)

Modify the standard procedure as follows:

1. Reach under the pack cover and unfasten the chest strap.

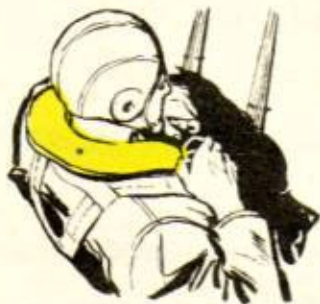

2. Pull yourself well back in the sling and undo the leg straps, if you have time.
3. As soon as you are in the water, release both sides of chest pack from harness and immediately swim upwind, away from the canopy and lines.
4. Inflate the Mae West, one half at a time, but never until the chest strap is unfastened.
5. When clear of the canopy and shroud lines, you can slip out of your harness at leisure.

Water



Procedure for Single Point Quick Release Harness

Modify the standard procedure as follows:

1. Before reaching the water, turn the locking cap 90° to set the release mechanism for immediate operation.
2. As soon as you are in the water, but not before, pull the safety clip, and press hard on the cap to release the lock. The harness will then slide off.
3. Inflate the Mae West, one half at a time, but never until the harness has been released.
4. Stay clear of the parachute.

(See Life Vest, BIF 9-14-1 and Life Raft, BIF 9-18-1)

WARNING: The canopy and shroud lines, **not the harness**, may tangle you dangerously after landing in water. When equipped with any quick attachable chest pack, first unfasten the entire pack from the harness, then get away from the canopy and lines before you stop to take off the harness. **Think it through now and you'll be safe later.**

On over-water flights, **always** carry a sharp, serviceable knife where it is easily accessible. If you experience difficulty releasing yourself from the harness after landing in water, stay calm and cut yourself free.

NIGHT JUMPS

As soon as you are in the chute, prepare for a normal landing. Since you cannot see the ground on a dark night, you want to be ready to make contact at any moment. **Get your feet and knees together, your legs slightly bent. Hang onto the risers above your head and wait for contact.**

HIGH ALTITUDE JUMPS

Bail-outs from high altitudes present special problems. The higher the altitude, the greater the dangers in bailing out. Stay with the airplane as long as you safely can; down to 15,000 feet if possible. If you must leave the airplane at altitudes above 15,000 feet and if you do not have bail-out oxygen equipment, take a deep breath of pure oxygen and hold your breath. Dive out and continue to hold your breath as long as you can before pulling the ripcord.

Except in extreme emergency, do not attempt a bail-out without bail-out oxygen equipment above 30,000 feet.

The chief hazards of high altitude jumping are:

1. Intense cold.
2. Lack of oxygen.
3. High G forces induced by the parachute opening at high altitudes.

If it is necessary to bail out at high altitude, you can reduce the hazard by making a long free fall to about 10,000 feet before pulling your ripcord. A free fall enables you to reach warmer regions more rapidly, reduces the hazard of anoxia, and insures less shock when the parachute opens.

At high altitudes the opening shock of the para-

chute develops excessive G forces. The higher the altitude, the greater the shock.

Judging Altitude in Free Falls

Do not depend upon counting or timing to judge distance above the ground. In the excitement it is difficult if not impossible to judge time.

Look at the ground and judge your altitude. For instance, at 5000 feet the earth begins to look green, you can distinguish details, the horizon spreads, and the ground rushes up at you.

Changing Your Falling Attitude

If your falling attitude is such that you can't see the ground, you can alter your position by extending an arm and the resulting turn will give you a look at the ground. Then pull in your arm and legs and straighten out your knees to stop tumbling before you pull the ripcord.

Terminal Speed

Remember that in many emergency jumps you may leave the airplane at speeds so high that an immediate parachute opening would be dangerous. Hence, if you have sufficient altitude, you should wait 5 to 15 seconds to slow down before pulling the ripcord. This will avoid injury to yourself or damage to your parachute. You actually slow down during the first 10 to 15 seconds in a free fall until you reach terminal velocity. The lower the altitude, the lower the terminal velocity. So in making a free fall you do not tend to fall faster the longer you fall. You actually fall slower and slower the lower you get because the air becomes denser. With your parachute open, the rate of descent is also slower the lower you get.

Notice

In all jumps from above 10,000 feet, fall free to 10,000 feet or less before pulling the ripcord if you can. This will reduce your exposure to cold, anoxia, enemy action, and lessen the opening shock of the parachute. If you do not have bail-out oxygen equipment, just hold your breath and dive out. Then continue to hold your breath as long as possible before pulling the ripcord.

Parachute Types



BACK-TYPE PARACHUTES

Type B-7 (AN6512). The chest straps and leg straps have bayonet type or snap fasteners. Note parachute belt is worn outside harness to hold webbing snug.

Type B-8. Flexible back pack with bayonet type fasteners on chest and leg straps. Older type B-8 parachutes have snap fasteners.

Type B-9. Flexible back pack on single point quick release harness. To get out of quick release harness turn the cap clockwise 90°, pull safety clip, and strike the cap a sharp blow with the hand.



Cap is shown in safetied position.



SEAT-TYPE PARACHUTES

Type S-1, S-2, AN6510, and AN6511. Harness has back and seat pad. Chest and leg straps have snap or bayonet fasteners.

Type S-5. Same chute as S-1 with single point quick release harness.

ATTACHABLE CHEST-TYPE PARACHUTES

Group 1 Assemblies

Type QAC (AN6513-1). Quick attachable chest-type parachute with square pack. Harness has snap fasteners on chest and leg straps. It has D-rings for attachment of pack.

Type QAC (AN6513-1A). Quick attachable chest-type parachute with barrel-type pack. Harness has snap fasteners on chest and leg straps. It has D-rings for attachment of pack.

Note: On both AN6513-1 and AN6513-1A parachute assemblies the snaps are on the pack and the D-rings are on the harness. Either of these packs can be used with the harness shown.

Group 2 Assemblies

Type A-3. Quick attachable chest-type parachute with barrel type pack. Harness has bayonet type fasteners.

Type A-4. Quick attachable chest-type parachute with barrel-type pack and single point quick release harness.

Note: On the A-3 and A-4 parachute assemblies the rings are on the pack and the snaps are on the harness. This pack can be used with either of the harnesses shown.

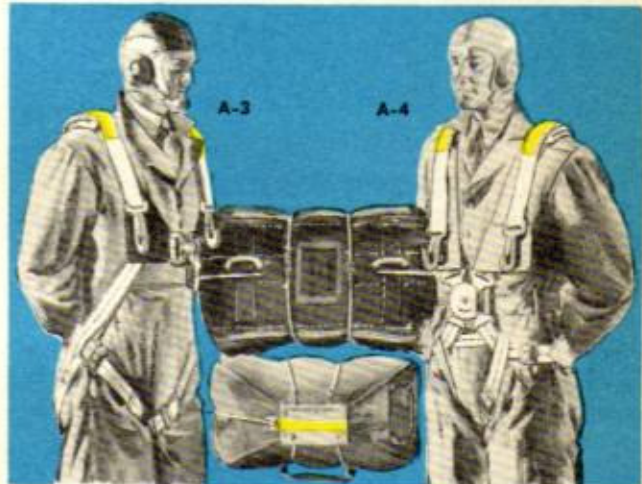

Caution!

Parachutes in Group 1 are not interchangeable with parachutes in Group 2.

Each crew member is responsible for making sure that the parts of his quick attachable parachute are not mismatched.

Before takeoff the bombardier should:

1. Inspect his attachable parachute to see if the pack will fit the harness. Snap each

pack to its harness to make certain.

2. Help others inspect all attachable parachute assemblies (packs and harnesses) in the airplane and make certain that all are in Group 1 or that all are in Group 2.

This prevents danger of mismatching.

Group 1 parachutes and harnesses are marked with red webbing.

Group 2 parachutes and harnesses are marked with yellow webbing.

Make sure all packs and harnesses in your plane are the same color.

REFERENCE: Technical Order 13-5-39

LIFE PRESERVER VEST



Wear your life vest whenever you fly over water.

When the vest is issued to you, put it on, inflate it by the mouth tubes. Adjust the straps. **With the vest inflated the waist strap should be tight, the crotch and back straps snug. After adjusting the back strap hand tack it to the waist strap.** Deflate the vest by opening the valves at the base of the mouth tubes. Roll the vest up to deflate completely. Be sure to close the valves tightly to prevent leak on automatic inflation. Wear the vest over the clothing and **under the parachute harness.** Tuck the vest under the collar of your flight jacket.

To inflate, pull one cord at a time so that if the mouth valves have been left open you will discover the error before you have discharged both CO₂ cartridges. One compartment will support you and will interfere less with swimming.

If the vest leaks, or fails to inflate completely from the CO₂ cartridge, fill by blowing into the mouth tubes. Open the valves while filling the vest by mouth, then reclose the valves tightly.

Note: Cutting off or bending the mouth tubes flush with the retaining loop will prevent possible injury to your eye at the time your parachute opens.

Before each flight remove the cap from the in-

flator cylinder and inspect the CO₂ cartridge. If the seal at the tip is punctured replace the cartridge. With the lever which actuates the puncturing pin in the up position, parallel to the container, insert the new cartridge, seal end down. Always check the cap to be sure it is screwed down tightly.

REFERENCES: Technical Order 13-1-8 and Technical Order 13-1-17.

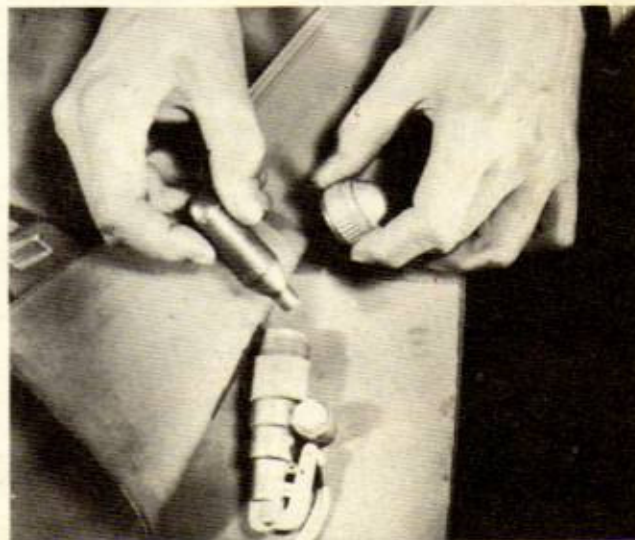

Inserting CO₂ inflator. Screw cap down tight.

Sea Marker Packet

A sea marker packet is cemented to the life vest. When friendly airplanes approach, release the packet by pulling down on the tab. The dye will form a large green area lasting three to four hours. This will help airplanes to find you.

Caution

Before takeoff be sure your life vest cartridge containers are loaded with live CO₂ cartridges, and that the container caps are screwed down tightly.

Always make certain that the mouth inflator valves are tightly closed before pulling the inflating cords.

Turn in your life vest for inspection every six months.

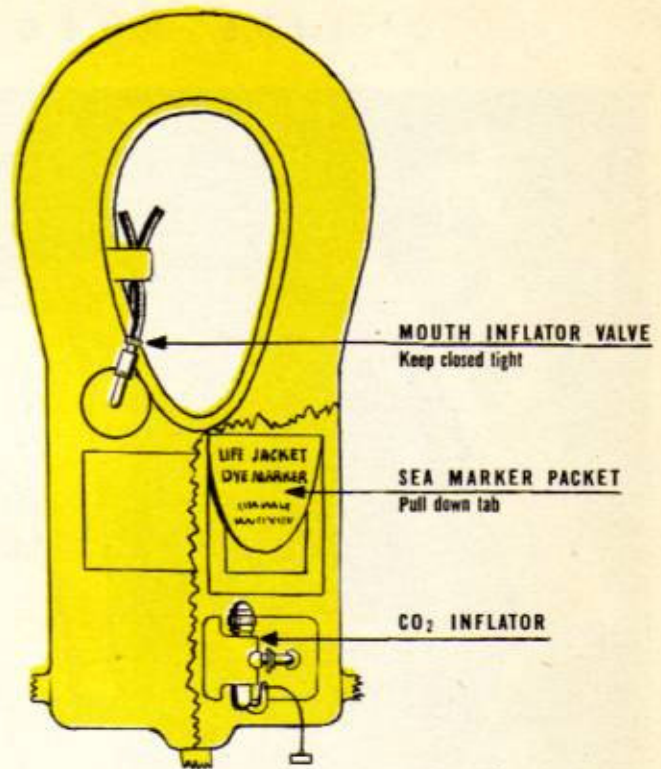

WARNING: STAY AWAY FROM YOUR CHUTE IN THE WATER

After parachuting into water you will have a tendency to drift downwind into the fallen parachute as soon as you inflate your life vest. To avoid entanglement with harness and shroud lines, work

upwind, away from the chute, and stay clear. If you have a raft, salvage your parachute for sail, cover, and extra lines. If not, get away from the chute and stay away.

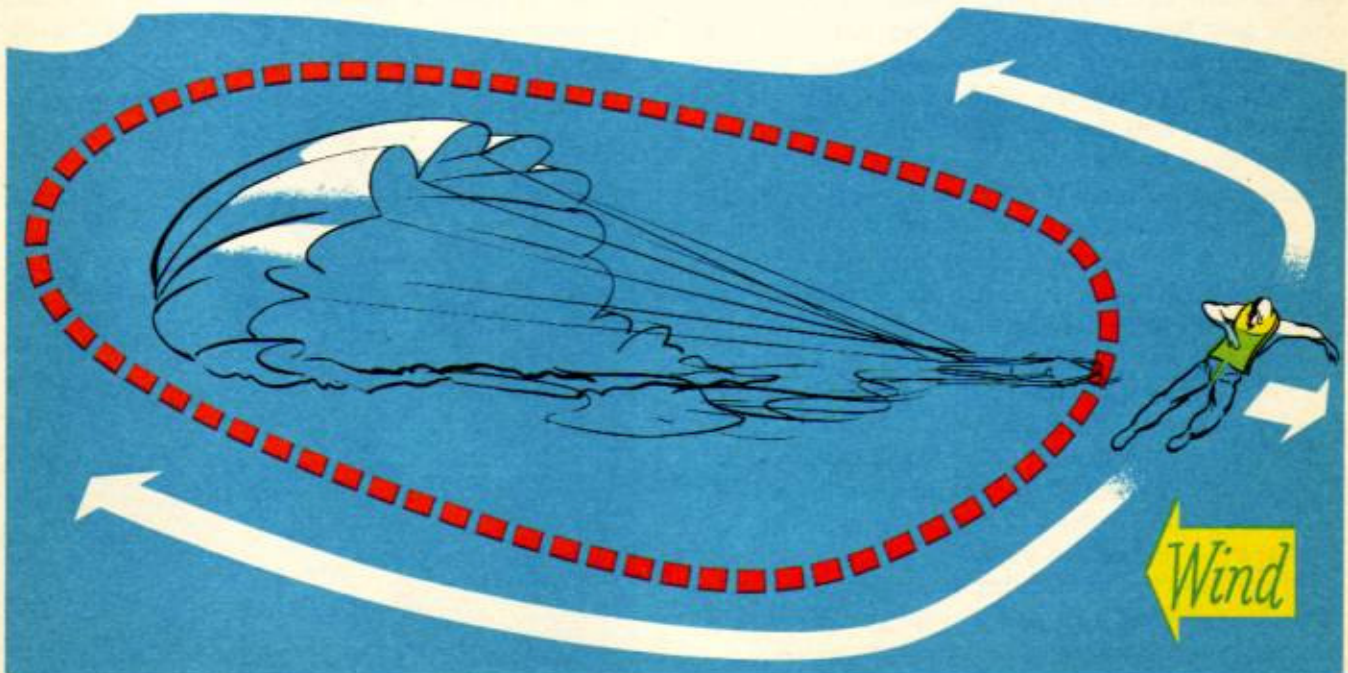

Swimming Through Fire

When an airplane is ditched at sea there is always the possibility that a smashed wing tank and engine will spread flaming oil and gasoline on the water. By using the following procedure, however, you can swim to safety through such a fire, even when you wear a life vest.



1. Jump feet first upwind of your airplane. Cover your eyes, nose and mouth with both hands. Take a deep breath. Hold breath until you rise to the surface.



2. Just before you reach the surface, make a breathing hole in the flames. Swing your arms overhead to splash flames away from head, face, and arms.



3. Swim into the wind. Use the breast stroke. Before taking each stroke splash water ahead and to the sides. Keep mouth and nose close to the water. Duck your head every third or fourth stroke to keep it cool. If there are several men, swim single file. Let the strongest swimmer splash a path so the rest can follow safely in his wake.



Swimming Under Water

If the heat is too intense or flames too high, swim underwater—out of the danger area. To do this:

1. Splash flames away from body.
2. Hold head near water level.
3. Deflate life vest by releasing valves.
4. Take a deep breath but do not inhale fumes.
5. Sink beneath the surface, feet first.
6. Swim upwind as far as possible.
7. Splash away the flames as you come to the surface. Take a deep breath and submerge again. Repeat procedure until you are beyond the fire.
8. Re-inflate life vest by mouth.



Some day you may be forced down at sea. Now is the time to start preparing for such an emergency. Here is how to do it:

1. Know the part you play in ditching a land airplane on water.
2. Know the use of emergency equipment provided for ditching purposes.



**PREPARE
FOR DITCHING**

Ditching and dinghy drills will familiarize you with the duties you are to perform when the order, "Prepare for ditching," is given. Master these drills so that you can carry them out in a darkened airplane under unfavorable conditions.

Inspections

However, before taking off on a long over-water mission, there are several additional points of importance to consider:

1. Be sure all your emergency equipment functions properly and that you have all you may need

in the airplane. Pay particular attention to CO₂ cartridges on your life raft and Mae West. See that the valves are closed.

2. Test your escape hatch. Know—don't hope—that it will operate if the need arises.
3. Recheck life vest adjustments. Blow the vest up by mouth and see that the waist and leg straps fit you properly. Make sure they won't bind if you have to inflate the life vest in an emergency.

Before Ditching

At the pilot's command, "Prepare for ditching," you must:

1. Acknowledge the order by saying, "Bombardier ditching."
2. Remove your oxygen mask as soon as you are below 12,000 feet. Loosen shirt, remove tie. Take off heavy boots and flak suit, but keep on flying clothing and helmet for protection.
3. Remove parachute, except when you need the one-man life raft attached to the harness.
4. Do not remove life vest. Keep it on at all times. **Do not inflate it until out of the airplane.** If you inflate your life vest while you are still in the airplane, you will find it difficult, if not impossible, to get out through an escape hatch.
5. Dismount bombsight and throw it overboard.
6. Open bomb bay doors. Jettison bombs, if the plane has sufficient altitude. Bombs and depth

charges, if not dumped, **must be placed on safe.** Assist in jettisoning all loose equipment in forward compartment. Shoot out ammunition from front turrets. Close and check bomb bay doors.

7. Gather equipment needed in life raft, proceed to ditching position, and await pilot's order or signal to "Brace for ditching."

8. Regardless of the airplane, two impacts will always be felt—the first, a mild jolt when the tail drags the water; the second, a severe shock when the nose strikes. **You must hold your crash position until the airplane comes to a stop.** Casualties occur when men relax immediately after the first impact.

Ditching Position

You must follow the standard ditching position recommended for your type of combat airplane in the AAF ditching posters.

If there is no poster on your airplane, or you can't use the position recommended because of differences of stowage or structural variations, remember the following:

General Rules

1. The best ditching position is to sit facing the tail of the plane, knees drawn up, back and head braced against a solid structure. If your head extends above the support, clasp your fingers tightly behind it to hold it from being snapped back.

2. The second position is to lie on the floor of the

airplane, head to the rear and feet firmly braced against a solid structure. Bend the knees slightly.

The best position for an injured man is the seated one. If such a position is not the injured man's regular one, have him trade places with someone.

If there is not enough bulkhead room for everyone aboard to brace against, if there are extra people in a compartment, it will be necessary for some to sit, facing aft, back braced against the shins of the forward man, feet and knees drawn up, hands clasped behind head.

3. Another position, in airplanes which are equipped with ditching belts, is to brace against the belts.

Abandoning the Airplane

Take out whatever emergency equipment you've been instructed to take in dinghy drills.

Inflate your life vest as soon as you are out of the airplane.

Launch and board rafts from the wing tips if possible, to avoid damaging rafts on jagged edges.

Don't jump into the raft; you'll go right through the fabric. Don't climb on to an inverted raft. You will only expel the air underneath and make the raft more difficult to turn over. Right it from the wing of the airplane if you can.

Paddle away from the airplane and tie the rafts together if there are more than one. Stay near the airplane as long as it stays afloat. It will be easier for rescuers to spot you.



LIFE RAFT KITS AND DISCIPLINE



Equipment

Learn the use of life raft equipment now. Don't wait until you really need it. Ask your Personal Equipment Officer to demonstrate its use, and make the most of crew drills.

The parachute is a valuable item of equipment in a life raft. If possible, take at least one out of your plane when abandoning it. The parachute will float for about 5 minutes when packed. Parts of the canopy can be used for bandages, sunshade, or as a sea anchor. The shroud lines can be used for fastening and in rigging the sunshade.

If there are two or more rafts, connect them with line provided, to keep them from becoming separated. Fasten the kit and all loose gear to the raft with tight but easily untied knots.

Get the emergency radio into operation as soon as weather permits. Instructions are on the set. Keep all signaling equipment where you can get at it quickly. Keep flares, Very pistol, and cartridges as dry as possible. Use a flare only when a ship or

plane is near. Fire the pistol almost vertically for maximum height and ahead of the plane so that the shot will be within the visibility range of the pilot.

Use the tarpaulin, yellow side up for a signal, blue side up for camouflage from the enemy.

Keep the sea anchor out. It will head you into the wind or check your drift.

Water and Food

Before any over-water flight, drink all the water you can. Contrary to popular belief, the body can store water. Don't run the possible risk of starting your raft expedition thirsty. The pilot is in charge of water rationing. Uninjured survivors should drink no water the first day. Each person should then drink a pint a day until the supply is exhausted. But don't give up even then. With care and good luck you can still survive for several days, even without water.

To cut down on your water requirements:

Rest as much as possible.

Expose your body to the breeze as much as possible, but protect against sunburn.

Shade your body without cutting off the breeze.

Keep clothing wet with sea water during the day, but not to the point of chilling.

If it rains, collect rainwater in the tarpaulin or sail after first rinsing off the salt. Then drink your fill slowly over the course of an hour or more. Store the remainder in all available containers. Then return to the ration of a pint a day.

Never drink sea water, urine, or compass fluid.

Don't eat flesh of fish, turtles, or birds, except in small quantities, unless you have a good water supply. If it makes you thirsty don't eat it at all.



Protection

Protection from the sun is vital in the tropics. By keeping shaded you will prevent sunburn and cut down on your water loss through perspiration. Rig the oars and tarpaulin as a canopy and stay in the shade. Your face, neck, arms, and legs are most liable to sunburn. Protect them. Wrap exposed parts of the body with a piece of parachute, bandage, handkerchief, or a strip of underwear. Wet yourself, clothing and all, with sea water, but keep the water out of your mouth.

Continued exposure to sea water in the raft may result in a condition called **immersion foot**. When this occurs the legs and feet become swollen, sore, and numb, and blisters may form. You can help prevent immersion foot by keeping your feet as dry as possible and by moving them to encourage circulation. If they become swollen, don't rub them; this will only make them worse. Instead, cover them with the ointment in the first-aid kit and wrap them loosely with bandage or a strip of parachute.

Cover burns and skin irritations with the ointment and a light bandage. Don't prick or squeeze boils;

bandage them instead.

You may go several days without a bowel movement. This is not harmful and is to be expected. Never take a salt water enema or a laxative. They increase your water loss.

Establish a watch routine if more than one man is aboard. Someone should always be on the alert.

Tie all injured persons to the raft, and as many others as your rope will allow.

LIFE RAFT KIT

Accessories for multiplace life rafts are carried in a kit and include the following items:

Signal kit (Pyrotechnic projector and 6 flares).

Emergency drinking water, 7 cans. Don't open before flight or water will spoil. Save cans for storing rain water.

Sea marker, 3 cans. When you see a plane, pour a can of marker on the water and stir it with an oar so it will spread. Do this quickly.

Life raft rations, 7 cans.

Flashlight, hand energized.

Knife, floating, cemented to raft.

Police whistle, to attract attention.

First-aid kit (Medical Supply Catalog, #9776900).

Fishing kit. Don't let hooks puncture raft.

Paulin for use as a sail.

Paulin for signal, shade, camouflage, and catching rain water.

Sun protective ointment, 4 tubes.

Emergency signaling mirror.

Wrist compass.

Religious booklets.

Water containers, 4.

Cellulose sponge.

Aluminum oars, 3.

Hand pump and hose.

Repair kit.

Bailing bucket. Use it also for urinating; don't stand in raft.

Repair plugs, 4.

Ocean charts.

Gatty's Raft Book.

Survival booklet.

Twine, 40 feet. Tie loose equipment to life raft.

Sea anchor.

Warning

Be sure life raft is completely deflated before storing it away in the airplane. Use deflating pump. Air or carbon dioxide left in the life raft will expand at altitude.

One man



Raft lanyard goes under harness and clips to life vest ring.

Preflight

The one-man life raft is stowed in a seat pack attached to the parachute harness. It is inflated after the jumper strikes the water.

When you put on parachute and life raft pack, clip the lead strap from the raft to the ring of the life vest waist strap under the harness. Otherwise you will lose the raft pack when you get out of the harness.

Before flight unsnap the pack cover far enough to expose the CO₂ cylinder. Test the locking pin.

In the Water

Pull open pack cover. Pull locking pin out of valve handle and open valve to inflate. Enter raft from small end by grasping hand straps and pulling.

Aboard the Raft

Keep your life vest on.

Top off inflation by blowing in the rubber mouth tube. Tighten valve after inflating.

Keep the CO₂ cylinder on the valve. The valve might leak if exposed.

Keep the lead strap from raft clipped to yourself.

Fasten down everything aboard.

The raft contains sea marker, sea anchor, bailing bucket, bullet-hole plugs, blue and yellow cloth, first-aid kit, repair kit, paddles, and water. The water may be replaced by a chemical sea water purification kit in some rafts.

LIFE RAFT



To inflate raft pull out locking pin and open valve slowly.



Board raft from small end by pulling it under you.



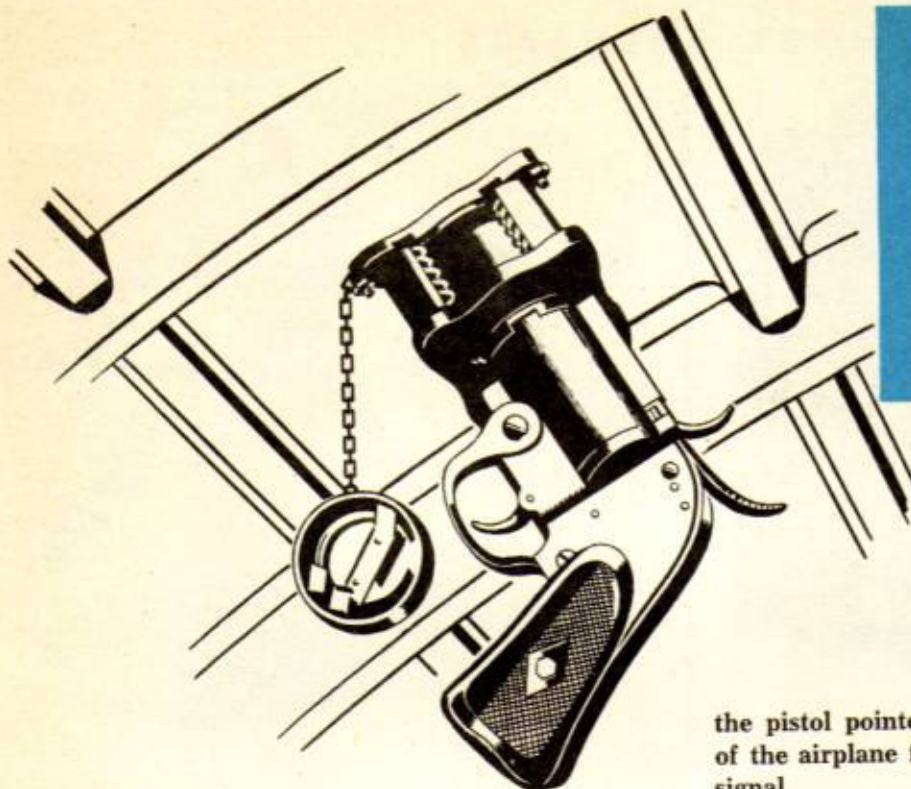

SIGNAL DEVICES

PYROTECHNIC PISTOLS

When radio communication is inadvisable or when radio equipment has failed, brief coded messages may be sent with pyrotechnic signals. Do not use pyrotechnic signals to control important operations unless no other means is available. The various colored signals which are available for use with M2 and AN-M8 pyrotechnic pistols are assigned different meanings under a code that is changed at frequent intervals in each edition of Signal Operation Instructions. The M11, red star parachute signal, however, is always used as a distress signal to be fired from the ground or from a life raft.

M2 Pistol

The M2 pyrotechnic pistol has a strong recoil. Use both hands to fire it if practicable. The signals themselves burn with an extremely hot flame; observe every reasonable precaution while handling or firing them.

1. Fire signals only from airplane in flight with the exception of the M11 distress signal.
2. Fire straight up or down. Use upper hatches, bomb bay doors, or flare chute if provided.
3. If a signal fails to ignite on the first attempt, try at least twice more. If third or final try fails, keep

the pistol pointed overboard and clear of all parts of the airplane for at least 30 seconds, then discard signal.

4. Discard a misfired signal, if possible, without handling the signal itself. One method is to hold the pistol over an opening in the airplane and release the cartridge by pressing on the latch and allowing the signal to fall clear under the force of gravity. The force of the air blast prevents holding the pistol on the outside of most airplanes. **Be careful to prevent discarded signal from striking any part of the airplane.**

5. Do not discard misfired signals when flying over populated areas.

6. Fire the M11 distress signal as nearly straight up as is practicable.

AN-M8 Pistol

The AN-M8 pyrotechnic pistol is replacing the M2 pistol. It is fired by inserting and locking the barrel in an M-1 mount. This mount is really a little door, fastened rigidly to the airplane, that permits the pistol barrel to extend through the airplane outer skin. The mount absorbs the recoil of the pistol. Observe these precautions in using this pistol:

1. Place cartridge in chamber after pistol is inserted in mount, and only when immediate use is anticipated.
2. Since the pistol is cocked at all times when the breech is closed, **never leave a live signal in the pistol when it is removed from the mount.**

SMOKE GRENADES



M 8 GRENADE

Airplanes to be flown over sparsely settled regions will be equipped with either an M8 or an M3 smoke grenade. In the event of a forced landing, use the grenade as a marker to aid searching parties in locating the airplane which otherwise might be difficult to find.

Pilots observing smoke of the type produced by M8 or M3 smoke grenades will immediately attempt to locate the source.

The M8 smoke grenade burns about 3½ minutes, giving off a dense **gray** smoke, and is intended to be used primarily in heavily forested regions. It is easily distinguished from wood fires which give off a blue-gray or black smoke.

The M3 smoke grenade is designed to be used in snow-covered regions. It gives off a dense **red** smoke for 2 minutes which can be distinguished against a white snow background for about 4 miles by a person in an airplane.

Method of Firing M8 Smoke Grenade

1. Grasp the grenade with lever held firmly against grenade body.
2. Withdraw safety pin, keeping a firm grip around the grenade and lever.
3. Either throw the grenade with a full swing of the arm, or place on the ground and release.



M 3 GRENADE

4. As the grenade is released from the hand, the lever drops away, allowing the striker to fire the primer.

Method of Firing M3 Smoke Grenade

1. Pull the 3 vanes on the side of the grenade up and away from grenade body.
2. Place grenade in snow so that it is supported by the vanes in an upright position.
3. Keep lever held firmly against grenade and withdraw safety pin.
4. Release lever.

Safety Precautions

To avoid a fire, do not throw or place the grenade within 5 feet of dry grass or other readily inflammable material.

After the grenade is ignited, stay at least 5 feet away from the burning grenade, as heavy smoke develops and there is a tendency to throw off hot particles of residue.

Keep these smoke grenades dry. If the chemical contents of a grenade become wet, it will ignite.

All smoke grenades will be shipped and handled in accordance with Interstate Commerce regulations. These regulations prohibit the shipment of these smoke grenades in personal baggage.

REFERENCE: Technical Order 01-1-38

Body Signals

If a rescue plane flies low and circles your location and you are sure that you have attracted the pilot's attention, you can transmit messages by the emergency body signals shown on this page. When performing the signals stand in the open. Make sure that the background as it will be seen from the airplane is not confusing. Make the motions deliberately and slowly, and repeat each signal until the pilot indicates that he understands.



Need Medical Assistance—Urgent (Lie prone)



All O K
Do Not Wait



Can Proceed Shortly
Wait if Practicable



Need Mechanical Help
or Parts—Long Delay



Pick Us Up—
Plane Abandoned



Do Not Attempt
to Land Here



Land Here (Point in
Direction of Landing)



Our Receiver
Is Operating



Use Drop
Message



Affirmative (Yes)



Negative (No)

HOW PLANE ANSWERS

The pilot of the rescue plane will answer your messages either by dropping a note or by dipping the nose of his plane for the affirmative (yes) and fishtailing his plane for the negative (no).



Affirmative (Yes). Dip Nose of Plane



Negative (No). Fishtail Plane

Panel Signals

Many of the emergency kits now supplied contain a large signal panel (roughly 10 feet x 10 feet). It is arc fluorescent yellow on one side and blue on the other. Immediately after you are forced down this panel should be spread out on the ground flat—yellow side up on dark backgrounds and blue side up on light backgrounds. The color will help rescue pilots to find you. Once a rescue pilot has located you, messages can be transmitted by folding the panel as indicated in the illustrations on these pages. If it is windy, hold the folds in place with rocks, sand, sticks, or improvised stakes if it is necessary. If several messages are to be transmitted don't change the folds too quickly. Allow enough time for the pilot of the rescue plane to read each signal and indicate that he understands it (generally by dipping the nose of his plane several times). These same signals can be transmitted with the square yellow-and-blue sail now a part of the equipment supplied with the large inflatable rubber life raft.

The emergency signal panel also can be used as a tent since its blue side is coated with a waterproof compound. Also, the blue side can be used as an excellent camouflage cover for a life raft if enemy aircraft are sighted.

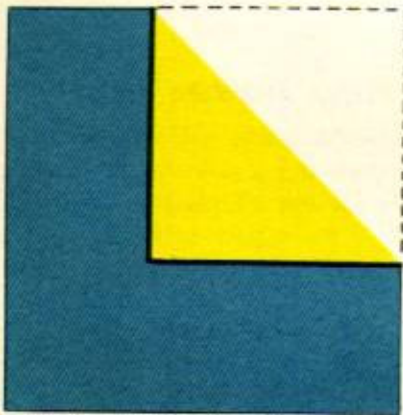

Need Gasoline and Oil,
Plane is Flyable

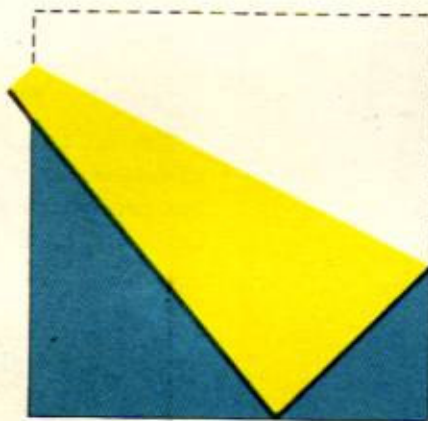

Need Tools,
Plane is Flyable

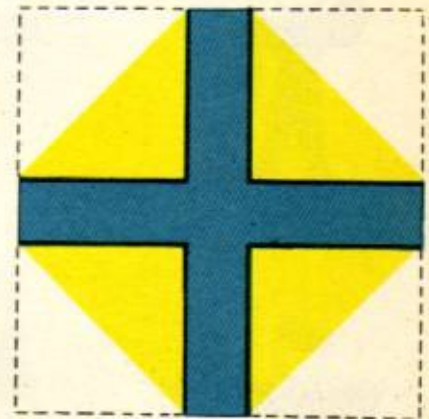

Need Medical Attention



OK to Land, Arrow
Shows Landing Direction

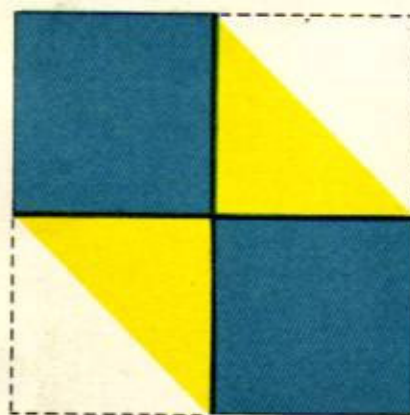

Do Not Attempt
Landing



Indicate Direction of
Nearest Civilization

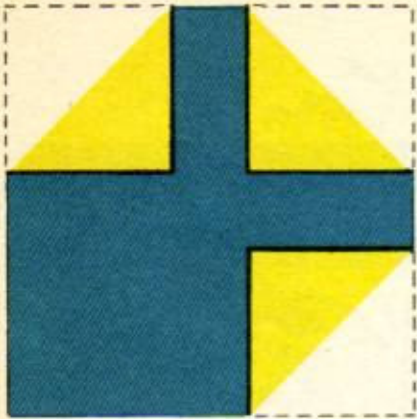

Need First-Aid Supplies

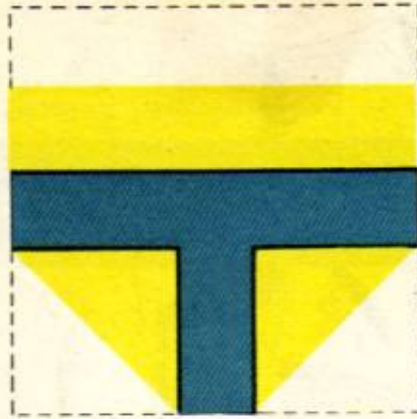

Need Quinine or Atabrine

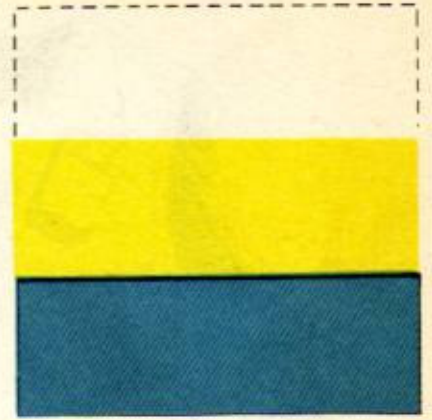

Should We Wait For Rescue Plane?



Need Food and Water

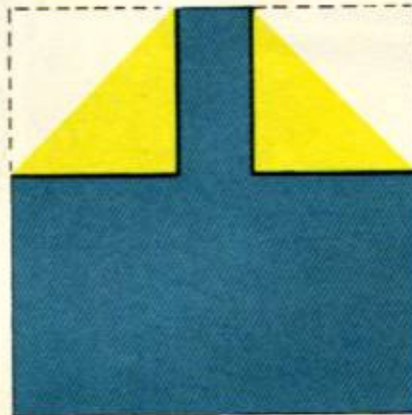

Need Warm Clothing

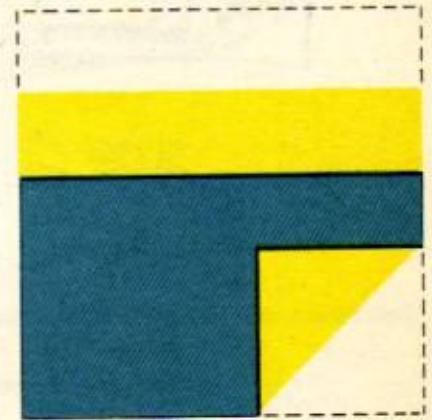

Have Abandoned Plane, Walking in This Direction →

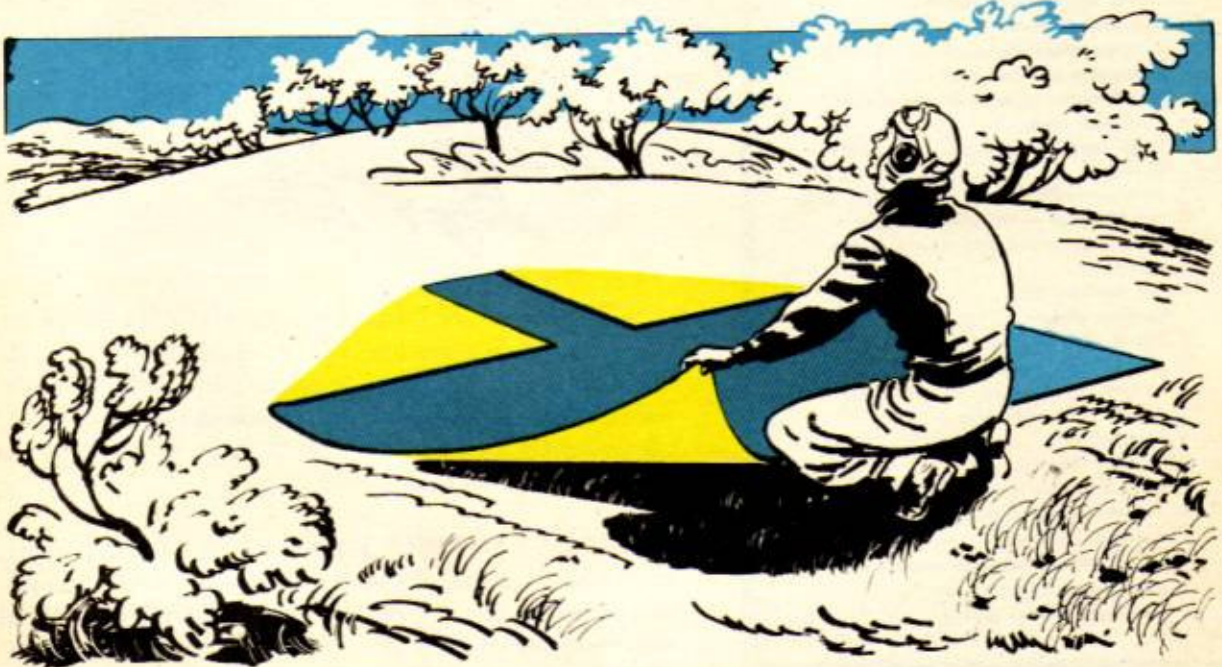



The following items of equipment are carried in the pockets of the vest:

- 1 hat (yellow on one side, OD on the other)
- 1 pair polaroid sun goggles
- 1 signal mirror, with lanyard
- 1 sharpening stone
- 1 fishing-sewing kit, in plastic container
- 1 collapsible spit and gaff
- 1 plastic water canteen (3-pint capacity)
- 1 Boy Scout knife
- 1 large knife (with 5-inch saw and blade)
- 1 package toilet tissue
- 10 yds bandage (with sulfa powder)
- 1 waterproof match-box with compass
- 20 matches
- 14 fire starting tabs
- 1 burning glass
- 1 signal whistle
- 1 oil container
- 1 waterproof cover for .45 cal. pistol
- 20 .45 cal. shot cartridges
- 1 First Aid Kit
- 1 Survival magual
- 2 vest-kit rations in tin containers
- 2 five-minute signal flares
- 1 mosquito headnet
- 1 collapsible container for boiling water
- 1 pair woolen insert gloves
- 1 pair leather outer gloves

Vest, Emergency Sustenance, Type C-1 was developed for the use of each crew member of an airplane forced down in isolated regions. It consists of an adjustable vest-like garment, fitted with pockets into which the items of the kit are conveniently stowed. The vest is to be worn under the life preserver vest and parachute.

PROTECT YOURSELF Before taking off on a flight over inaccessible or mountainous country, the Arctic, jungle, desert, or ocean, check your vest and be sure it contains all the necessary equipment. If it does not, check with your Personal Equipment Officer.

CLIMATE AND HEALTH

The AAF has circled the earth. Its flying operations are conducted over every type of terrain, desert, jungle, and Arctic, where the temperatures range from higher than 130°F to lower than -50°F. Each region presents special problems in living. Learn what they are and how to cope with them.

WARM CLIMATE HEALTH



In warm regions such as the tropics, desert, or jungle several weeks may be required for your body to become completely adapted to the heat. During this period protect yourself from sunstroke or heatstroke by following a few simple rules.

Clothing

During the daytime protect yourself from the severe burns which may result from exposure to the intense rays of the sun. Wear a cap or sun helmet and lightweight clothing which exposes as little of the body as possible. Clothing should be loose and porous to permit evaporation of sweat. This helps cool you. Get in the habit of shaking out your clothes before putting them on, so as to rid them of flies, insects, and snakes. Tinted goggles or sunglasses protect your eyes from the glare of the sun;

also from dust and sand. Protect exposed areas of body with sunburn protective ointment.

Don't sunbathe right away. It's dangerous, unless you develop a tan gradually. A good plan for sunning yourself is 5 minutes' exposure the first day, increased by 5 minutes each day until you are thoroughly tanned. Don't get burned!

Although the temperature may be intensely hot on the ground, the air is cooler the higher you climb; at high altitudes it is extremely cold. So be prepared to add or remove clothing according to the temperatures you encounter.

Even on the ground, nights are frequently cold in the desert. Anticipate rapid changes in temperature by having warm clothing available at night. Woolen socks are best for general use; they provide the greatest comfort because they absorb moisture well

and are good insulators. Wear GI shoes. They keep out sand and protect your feet better than oxfords. You can also walk home in them.

Water and Salt

If your water supply is limited, you must use it sparingly. With care you can get along on surprisingly little.

Keep physical exertion at a minimum. Exertion makes you sweat; sweating makes you thirsty. Stay out of the sun as much as possible. Do your heavy work in the shade and during the cooler hours of late afternoon, evening, or early morning. Cut down on your smoking as it makes you thirsty; chew gum instead. Rest as much as possible, and take advantage of the breeze. Go easy on alcoholic drinks. They increase your body's need for water.

If you find yourself sweating heavily, salt your food liberally at meals to help make up for the salt lost through sweat. Your Flight Surgeon may advise taking salt tablets in addition. Check with him on the dosage, for salt tablets may do more harm than good if your water ration is limited.

If your body loses too much salt through sweating, you may get **heat cramps** in your muscles.

Sunstroke is usually caused by prolonged exposure to the direct rays of the sun, although it may occur even in cloudy weather. It is a serious condition. Symptoms may include headache, dizziness, red spots before the eyes, and vomiting.

Heatstroke is a similar condition, resulting from exposure to excessive heat from any source.

All of these conditions can be prevented by avoiding sun, sweat, toil, and salt-loss as much as possible. A victim of sunstroke or heatstroke must have prompt treatment. Give him a bath in cold water, cover with wet sheets, or simply pour cold water over his clothes and fan him.



Disease

In the tropics and desert, certain diseases are usually present. Know what they are, how they are transmitted, and precautions to take, so you can avoid getting them. Guard constantly against:

- Insects
- Contaminated food and water
- Breaks in the skin's surface

Insects



Mosquitoes in the tropics are your greatest danger. They transmit malaria, yellow fever, dengue, and other diseases which can lay you low as surely and effectively as an enemy bullet. Mosquitoes breed in water. They usually rest in the shade during the



day and bite at night. In dense jungles or dark rooms, however, they may bite during the day.

Keep yourself covered at night. Wear long trousers, sleeves, gloves, and headnet. Smear exposed surfaces of the skin, such as your face and neck, with mosquito repellent every 3 or 4 hours during late afternoon and night. Apply carefully, as mosquitoes will find and bite every small untreated spot even though it is completely surrounded by repellent. After dusk stay away from native villages and swamps. In heavily infested areas, wear clothing

which has been treated with mosquito repellents.

Sleep under a bednet. Inspect and spray inside it to kill mosquitoes before entering. Tuck net under blanket or mattress. Keep it mended.

Use mosquito spray (Aerosol or DDT) liberally in your tents and buildings.

Malaria. This is one of the most widespread diseases in the world. It is a major military problem in South America, the Indies, Africa, the Middle East, India, Burma, Thailand, Indo-China, China, and Malaya. It is carried by the anopheles mosquito, which injects the malarial parasite into your blood.

The disease takes different forms with symptoms appearing about 2 weeks after infection. You may then experience headache, chills, fever, and other symptoms, depending on the type and severity of the disease. Prevention of malaria is largely up to you. Don't give the mosquitoes a chance. In certain regions you may be advised to take atabrine to help prevent malaria. If so, take it regularly, according to local directives and the instructions of your Flight Surgeon.

Other diseases transmitted by mosquitoes include:

Yellow Fever. Confined at present to Eastern and Central Africa and the bulge of South America. Vaccinations against this disease protect you.

Dengue (Breakbone fever) occurs in tropical regions, chiefly at the end of the rainy season. Symptoms consist of muscle and joint pains, backache, fever, and rash. The mosquito which transmits it bites mostly during the daytime. You must protect yourself from it to avoid the disease.

Besides mosquitoes there are other pests you should steer clear of:



Flies. They breed in filth and transmit the germs of dysentery and typhoid from human waste to your food. Protection against flies requires screening of latrines and kitchens, proper disposal of garbage, and frequent spraying with Aerosol or DDT. Special types of flies may transmit other diseases, such as sand-fly fever, yaws, and sleeping sickness.



Mites. Small six-legged insects about the size of a pinhead, sometimes known as red bugs or chiggers. They transmit typhus or scrub typhus (Tsutsugamushi fever). This disease is prevalent in the Southwest Pacific and the China-Burma-India theater. It results in headaches, chills, and fever. Cover the body, avoid sleeping on the ground, and wear clothing impregnated with anti-mite fluids or insect repellents, for protection.



Lice. They carry the germs of typhus fever and relapsing fever. Lice hide in the seams of dirty clothing and spread from one person to another. Boil infested clothing or sterilize with chemicals.



Fleas. Most fleas are harmless. In India and South China, however, rat fleas transmit the deadly disease called plague. Avoid this threat by spraying your quarters with Aerosol or DDT and keeping rats out.

Food and Water

In warm climates foods spoil quickly. There is danger also of contamination of food and water by germs which cause typhoid, dysentery and cholera. You can prevent typhoid and cholera, to a large

extent, by immunization injections. The dysenteries, however, cannot be prevented in this way. You must rely instead on sanitary measures and precautions. Know what foods are safe and how to protect yourself against those that may not be.

The safest food is served in Army messes. If canned rations are used they should be eaten soon after opening or stored in a cool place under fly-proof covers.

Food obtained from natives should be thoroughly cooked before eating. Thick-skinned fruits which can be peeled need not be cooked. Lettuce, radishes, celery, salad greens, melons, and strawberries are likely to carry disease germs. Never eat them raw. The natives commonly soak melons in water, often polluted, to increase their weight. Never use milk products such as butter, cheese, and ice cream, which are sold by the natives.

In desert and tropical regions, water also is important in transmitting intestinal infections. Consider all surface water unsafe, whether in streams, wells, fountains, ditches, or cisterns. Don't wash in it, don't brush your teeth with it, and above all don't drink it! Don't even put ice in your drinks unless the ice has been prepared by the Service. Native ice may harbor germs of dysentery or typhoid.

Water of questionable purity should always be sterilized before you use it. You can sterilize water in any one of three easy ways:

1. Boil it for at least 5 minutes.
2. Use Water Purification Tablets (Halazone). Add one tablet to the pint, shake, and wait a half-

hour before drinking.

3. Add three drops of iodine to the quart, shake, and wait a half-hour before drinking.

Care of the Skin

In hot climates, skin troubles are common. Treat even trivial cuts, scratches, and bites promptly (See BIF 9-1-1) or serious infection may result. Don't hesitate to see your Flight Surgeon. The following precautions will help keep you out of trouble.

Never walk about with bare feet in warm climates. Floors are likely to harbor the germ that causes athlete's foot. Consider all native areas infected. Small worms in the soil may burrow into the skin and cause infections such as hookworm or bilharziasis. Don't go swimming on beaches near native villages. The water may be contaminated with the flukes which cause schistosomiasis.

Bathe yourself and change your socks and underwear as often as possible. Keep the skin folds between the toes, in the armpits, and the groin clean and dry to prevent fungus infections like ringworm. Powder these parts liberally with GI foot powder.

Venereal Diseases

In the tropics, venereal diseases are common among prostitutes and most native women as well. In addition to syphilis and gonorrhea, large numbers of them are infected with chancroid, lymphogranuloma venereum, and granuloma inguinale. Don't give them a chance to give it to you. The treatment of these diseases is longer than their names.



COLD CLIMATE HEALTH

The principal hazard in cold weather operations is frostbite. It can be more serious than most people realize. It can cost you a finger or toe, even a hand or foot. Protect yourself with the proper equipment and by observing a few simple principles.

Clothing

All clothing should fit loosely. This applies particularly to your socks, boots, and gloves. Tight-fitting clothing interferes with the blood circulation and makes you more susceptible to frostbite. Individual garments should be light and porous. Wear several layers if possible. Two light garments afford better insulation than a single heavy one. Wear long woolen underwear on all flights over cold regions. Wear two or three pairs of loose-fitting woolen socks in sub-zero climates, but be sure that your boots fit loosely over them.

Leather shoes are dangerous in extreme cold. They not only afford poor protection, but may cause harm if they fit tightly over your socks. Don't wear ordinary GI shoes inside your winter flying boots. Use woolen socks and felt liners or electrically heated shoes instead.

If possible wear two pairs of gloves or mittens—a rayon or other light pair inside heavier ones (either A-9's, A-12's or electric gloves). Mittens are better than gloves, for they allow your fingers to come in contact with each other and help keep them warm.

Keep your socks and underwear clean. After they have become soiled by body oils and excretions, they lose much of their insulation value.

Keep Your Clothing Dry

Wet clothing is almost worthless in protecting you from the cold. If any part of your clothing becomes moist, either by accident or through perspiration, take it off and dry it over a fire or change to dry clothing immediately. Wet feet and hands are particularly dangerous in cold climates for they fall easy prey to frostbite.

Exercise to keep warm but guard against overexertion in extreme cold. Overexertion makes you sweat and the perspiration may turn to ice inside your clothing. This is dangerous. If necessary to perform much physical work, open or remove some of your clothing in order to prevent perspiration. Don't put on a heavy suit until just before takeoff. Wipe your body dry; then dress slowly. Once dressed, exercise no more than necessary.

Electrically Heated Flying Suits

Electrically heated flying suits permit you to fly for long periods at extreme altitudes without getting cold. They have the advantage of eliminating bulkiness and permitting greater ease in manipulating the controls. There is one great disadvantage, however, in relying on them while flying over cold regions. If

your electric system fails, if you are forced down, or if you have to bail out, you are left without adequate protection against the cold. Always carry additional heavy clothing with you on such flights.

Know how to use your electrically heated suit, and treat it carefully. The electric heating elements are fragile. Hang your suit up to dry between flights, if possible, and have it tested by your Personal Equipment Officer. Two types are now in use, the F-2 and the F-3. They will protect you down to -40°F . If lower temperatures are encountered, add other flying clothing.

How to Wear the F-2 Suit

1. Wear your F-2 electrical suit over long woolen underwear. (If your suit is the F-1 type, wear additional clothing over it as well.) The F-2 suit affords adequate protection down to -40°F . If operating at lower temperatures, add other flying clothing.

2. Put on the shoes with inserts over lightweight woolen socks. Then connect the snap fastener tabs on the trouser leg to the corresponding snaps on the shoe insert. **Be sure that both pairs of snaps are properly connected.**

3. Connect the tab at the top of the trousers to the corresponding snap fasteners on the inside of the jacket at the right. Make certain both pairs of snaps are securely snapped together. Connect 6-foot lead cord to jacket pigtail.

4. Put on regulation flying helmet and auxiliary equipment. Protect your neck from the cold by wearing a wool or silk scarf.

5. Put on lightweight rayon gloves. Snap the tabs on the jacket sleeves to the corresponding snaps on the heated gloves. Then put on the electrically heated gloves.

How to Wear the F-3 Suit

1. Begin to dress by putting on long woolen underwear, woolen socks, GI trousers, and shirt.

2. Then add the F-3 electrically heated trousers. Adjust the shoulder straps to fit comfortably. Your F-3 heated jacket goes on next. Make sure both trousers and jacket fit properly.

3. Connect cord on right underside of jacket to receptacle at waistline of trousers. **Make certain both prongs of plug fit into receptacle.**

4. Now put on heated shoe inserts. Type F-2 is used for both F-2 and F-3 suits. **Connect both snap fasteners** on each leg of the heated trousers to snaps on shoe inserts.

5. Next come the A-9 alpaca-lined trousers. Reach inside right or left pocket and pull electric cord or



F-2 ELECTRICALLY HEATED FLYING SUIT

Your complete F-2 wardrobe should contain the following items of clothing:

1. Jacket
2. Jacket Insert, Heated
3. Trouser
4. Trouser Insert, Heated
5. Helmet
6. Shoes, Felt
7. Shoe Insert, Heated
8. Gloves, Heated
9. Rayon Glove Inserts
10. A-12 Mittens
11. Scarf
12. Lead Cord
13. Woolen Shirt
14. Light Socks
15. Long Underwear

pigtail through. Then put on the B-10 jacket.

6. Now, the finishing touches: outer boots, helmet, and scarf. Connect 6-foot lead cord to pigtail.

7. Check all previous steps. Then add your gloves; first, the rayon or silk gloves. Then snap tabs on sleeves of heated jacket to snaps inside gauntlets of electrically heated gloves. Now put on your heated gloves. Take along a pair of A-9 mittens, in case of emergency.

8. You can plug an oxygen mask heater or electrically heated goggles into the connecting block on

the front of your trousers.

Connect your extension plug in the left receptacle of the built-in rheostat before takeoff and be sure that the suit is working properly. The plug can be locked into position by a simple clockwise twist. When in flight, keep the rheostat at the lowest comfortable heat. Don't ride hot, it will make you sweat.

Never rely on electrically heated suits alone when flying over cold regions. They are safe for use over temperate or tropical zones where cold is experienced only at high altitudes.



F-3 ELECTRICALLY HEATED FLYING SUIT

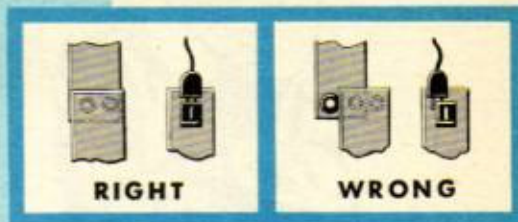

MAKE CONNECTIONS PROPERLY

Your complete F-3 wardrobe should contain the following items of clothing:

1. Jacket, Alpaca lined, Type B-10.
2. Jacket, Heated, Type F-3
3. Trousers, Alpaca lined, Type A-9
4. Trousers, Regulation G1
5. Trousers, Heated, Type F-3
6. Helmet
7. Shoes, outer felt or Type A-6
8. Gloves, Heated, Type F-2
9. Gloves, rayon or silk
10. Mittens, Type A-9
11. Scarf
12. Lead Cord
13. Shirt, Regulation G1
14. Socks, Regulation Wool
15. Long underwear

Check your suit after each flight. Look for excessive wear at all flexion points where electric wires might short out or break. If an ohmmeter is available, check the resistance of your suit at frequent intervals. The resistance in ohms is marked on the trousers, jacket, and each shoe and glove. If the ohmmeter shows the resistance to be more than 10% off, turn in the item for a new one.

Frostbite

Frostbite occurs most commonly in the fingers,

toes, nose, ears, chin, and cheeks. It may set in gradually and painlessly and without your being aware of it. Numbness, stiffness, and a whitish discoloration of the affected part are among the first signs. Wrinkle your face frequently when exposed to cold air; if it feels numb, warm the affected part with your ungloved hand until sensation returns.

Crew members should watch each other's faces and be on the alert for areas of blanching. In this way serious trouble can be prevented. Frostbitten tissues may later become painful. Such tissues should



Warm hands by placing inside clothes under armpit

never be rubbed. Never apply snow or ice to a frostbitten part. If your hand becomes cold or numb, warm it by placing it inside your clothing or under your armpit. Frostbitten tissues should always be thawed gradually. When possible, thaw them at ordinary room temperature. They should never be placed near a heater or immersed in warm water or in kerosene. Any of these procedures may cause irreparable damage.

If frostbite occurs, cover the frostbitten area with a loose sterile bandage. Keep the patient comfortably warm with blankets or a sleeping bag and by giving him hot drinks; and give him 100 per cent oxygen to breathe (Auto-Mix OFF or 100% OXYGEN). Report to your Flight Surgeon immediately after returning from your flight.

In extremely cold weather never touch cold metal with your bare hands, even for a moment. Your skin may freeze to it. If by accident this should happen, thaw your skin loose from the metal by warming the latter or by urinating upon it—don't pull your fingers loose.



Don't touch cold metal with bare hands

Snowblindness

Snowblindness is caused by exposure of your eyes, even for brief periods, to the glare which exists in snow-covered regions. The resultant damage to your eyes may cause intense pain and seriously interfere with your vision for several days—sometimes even longer. The hazard of snowblindness is particularly great on sunny days, but the glare



Wear colored goggles or sunglasses

which results from a bright overcast is almost as dangerous. Always protect your eyes by wearing colored goggles or sunglasses. In the Arctic, snowblindness may be brought on by merely lifting your goggles a half dozen times.

Body Heat

Eat an abundance of fatty foods while in cold regions. Fats are rich in calories, which help you maintain body heat. Take hot drinks such as coffee, tea, cocoa, or soup in thermos jugs along with you on all flights. These also add to your body warmth.

Never drink alcoholic beverages to keep warm. They give you a false sensation of warmth but may do great harm by actually robbing you of your body heat, since they cause flushing of the skin. This loss of heat, together with the false sense of security which alcohol produces, makes alcoholic beverages dangerous to anyone who is exposed to cold.



Don't eat snow! Melt it before drinking

INDEX

BOMBARDIERS' INFORMATION FILE

A

A-26 bomb racks and controls	7-8-1
Actual range (AR)	2-1-2
Actual range angle (AR \angle)	2-1-2
Actual time of fall (ATF)	2-1-2
Aeronautical charts	4-9-1, 8-3-2
Aids for bombardiers	2-5-1
Angles and their tangent values (graph)	2-5-4
Constants and conversion factors	2-5-1
DS compensation for trail deficiency	2-5-3
Finding GS with E-6B computer	2-5-2
Groundspeed (graph)	2-5-5
Equations	2-5-1
Horizontal distance from Sight \angle (graph)	2-5-6
Mil values of 1 rpm DS	2-5-3
Tan Drop \angle charts for E-6B computer	2-5-2
Air plot	4-10-2
Airspeed indicator	4-3-1
Calibration with bombsight	4-3-1
Calibration with measured course	4-3-3
Airspeed, true	2-1-1
Aldis lamp	1-6-4
Alphabet	1-6-4
Code	1-6-4
Phonetic	1-6-4
Altimeter	4-4-1
Calibration with alidade	4-4-1
Altitude, effects of high	9-4-1
Amplifier (autopilot)	5-1-4
AN Computer	3-3-3
Finding BA	3-3-3
Angles and their tangent values (graph)	2-5-1
Angles, tangents of	2-1-3
Anoxia (oxygen want)	9-4-1
Arming pin nose fuze	7-2-2
Arming vane nose fuze	7-2-2
Arming vane tail fuzes	7-2-1, 7-2-3
Artificial respiration	9-1-4
Astro-compass	4-7-1
Alignment	4-7-1
Cautions	4-7-1
Finding true bearing with	4-7-1
Finding true heading with	4-7-1

Automatic bombing computer	3-2-1
Finding wind with, and bombsight	3-2-2
Correction for precession	3-2-3
Installation and zeroing	3-2-1
Operation	3-2-3
Setting known wind on	3-2-2
When TAS exceeds 210 mph	3-2-3
Autopilot, C-1	5-1-1
Directional panel turns	5-5-1
Engaging procedure	5-3-1
Flight adjustments	5-4-1
Formation stick	5-7-1
Maladjustments	5-6-1
Nomenclature and functioning	5-1-1
Preflight procedure	5-3-1

B

B-24 bomb racks and controls	7-6-1
B-29 bomb racks and controls	7-7-1
Bailout bottles	9-6-2
Ballistic coefficient	2-1-1
Bendix chin turret (B-17)	7-10-1
Bleeding, how to stop	9-1-1
Body heat	9-21-8
Bomb arming controls (A-2)	7-4-5
Bomb hoist (C-3A)	7-4-5
Bomb racks and controls (general)	7-4-1, 7-5-1
Care of	7-4-5
Preflight procedure for	7-5-1
Bomb release mechanisms	7-4-3
A-2	7-4-3
A-4	7-4-3
Bomb shackles	7-4-4
B-7	7-4-4
B-9	7-4-4
B-10	7-4-4
D-6	7-4-4
D-7	7-4-4
Bombardier's checklist	8-1-1
Bombardier's control panel	7-4-2
Bombardiers' Information File	
Authority for	Intro. 5
Compliance	Intro. 7
How to use	Intro. 3
Table of contents	Intro. 1
Bombardier's Kit	1-3-1
Bombing altitude (BA)	2-1-1
Bombing altitude computations	3-3-1
Bombing analysis	2-4-1
Bombing errors, fixed-angle	2-3-6

from incorrect airspeed	2-3-6	Oiling	6-3-3
from incorrect BA	2-3-6	Optical system	6-1-6
from incorrect fore and aft bubble level	2-3-6	Precession runs	6-3-6
Bombing errors, synchronous	2-3-1	Preflight procedure	6-2-1
from improper ATF	2-3-2	Preflight of GBA	6-7-2
from improper course	2-3-4	Post-flight procedure	6-2-4
from improper rate	2-3-5	Range errors	6-4-1
from improper release	2-3-5	Rate motor inoperative	6-6-1
from improper trail	2-3-3	Rate end (preflight)	6-2-2
from improper vertical	2-3-1	Rate system	6-1-7
Bombing flight record (AAF Form 12C)	1-4-1	Reflex optics	6-8-3
Bombing intervalometer	7-4-6	Reflex sight	6-8-3
Calibration	7-4-6	Setting up ATF with stop watch	6-6-1
Cautions regarding	7-4-6	Setting up course	6-1-1
Operation	7-4-6	Solving for range	6-1-6
Bombing moving targets	2-1-4	Stabilizer, course knobs (preflight)	6-2-3
Bombing tables, how to use	2-2-1	Torque unit	6-1-5
Bombing through overcast (BTO)	8-13-1	Trail system	6-1-8
Procedure on A-2 trainer	8-13-3	Trail spotting device	6-8-2
Procedure on Supersonic trainer	8-13-3	Trouble shooting	6-4-1
Setting up course	8-13-2	Vertical gyro	6-1-6
Solving for rate	8-13-2	Vertical gyro and lighting (preflight)	6-2-4
Bombs	7-1-1	Vertical gyro failure	6-6-1
Chart	7-1-5	Briefing and Interrogation	8-2-1
Classification	7-1-2	Crew briefing	8-2-1
High explosives used	7-1-1	Interrogation	8-2-2
Bombsight and driftmeter alignment	4-8-1	Special bombardier briefing	8-2-1
Bombsight, M-series	6-1-1		
Adjustment inspection	6-3-4	C	
Anti-glare lenses	6-8-1	C-1 autopilot	5-1-1
Bombing with defective bombsight	6-6-1	C-2 computer	3-3-3
Cleaning	6-3-1	Finding BA	3-3-3
Constant	2-1-2	Caliber .50 machine gun	7-9-1
Cold, hot weather operation	6-5-1	Adjustments	7-9-1
Crosstrail mechanism	6-1-3, 6-2-1	Preflight	7-9-2
Deflection errors	6-4-1	Camera bombing	8-12-1
Directional gyro	6-1-5	with A-4 camera	8-12-1
Disc drive system	6-1-7	with K-22 or K-24 camera	8-12-2
DS and trail modifications	6-8-2	Check points	4-9-3, 8-3-6
Electrical inspections	6-3-3	Checklist, bombardier's	8-1-1
Failure of directional gyro	6-6-1	Classified material, safeguarding	1-5-1
Field inspection and care	6-3-1	Climate and health	9-21-1
Finding wind with, and AB computer	3-2-2	Clothing, cold climate	9-21-5
Glide bombing attachment (GBA)	6-7-1	Clothing, warm climate	9-21-1
Glide bombing with GBA	6-7-3	Code, Morse	1-6-4
Gyroscopes	6-1-4	Cold climate health	9-21-4
Installation (preflight)	6-2-1	Combat bombing	8-1-1
Level bombing with GBA	6-7-3	Bombardier's checklist	8-1-1
Mirror drive system	6-1-9	Bombing through overcast	8-13-1
Modifications, attachments	6-8-1	Briefing and interrogation	8-2-1
Mounting GBA	6-7-2		
Nomenclature, operation	6-1-1		

Camera bombing	8-12-1
Flak analysis and evasive action	8-5-1
Formation bombing	8-6-1
High altitude bombing	8-7-1
Maneuvering targets	8-11-1
Medium altitude bombing	8-8-1
Minimum altitude bombing	8-9-1
Tactical variations by theater	8-10-1
Target identification	8-3-1
Train bombing	8-4-1
Compass	4-5-1, 4-6-1, 4-7-1
Astro-compass	4-7-1
Gyro-stabilized flux gate	4-6-1
Magnetic	4-5-1
Radio	4-11-1
Computer grid, offset bombing	8-10-3
Computers	3-1-1
AB automatic bombing	3-2-1
AN altitude correction	3-3-3
C-2 altitude correction	3-3-3
J-1 sighting angle	3-5-1
G-1 true airspeed	3-4-1
E-6B dead reckoning	3-1-1
Constants and conversion factors	2-5-1
Course problem, solution of	2-1-3
Crew cooperation	1-1-1
Crosstrail (CT)	2-1-1
Crosstrail, range component of	2-1-4
Cuts, treatment of	9-1-1

D

Dangerous gases	9-9-1
Dashpot	5-4-2
Dead reckoning (DR) navigation	4-10-1
Death from whirling blades	9-12-1
Decompression sickness	9-9-3
Dengue	9-21-3
Directional panel turns	5-5-1
Manual turns	5-5-1
Turns through bombsight	5-5-1
Disc speed (DS)	2-1-2
Distance, horizontal, from Sight \angle	2-5-6
Ditching	9-16-1
Drift	2-1-1
Drift angle (Drift \angle)	2-1-3
DR logs	4-10-1
Driftmeter alignment, bombsight and	4-8-1
Dropping angle (Drop \angle)	2-1-2
DS compensation for trail deficiency	2-5-3
Duties of staff bombardier	1-2-1

E

E-6B computer	2-4-1, 2-5-2, 3-1-1, 3-3-3
Calculating fuel consumption	3-1-2
Converting distance measurements	3-1-1
Converting mph to ft/sec	3-1-1
Division	3-1-1
Finding bombing altitude	3-3-3
Finding groundspeed	2-5-2
Finding true airspeed	3-1-2
Finding true altitude	3-1-3
Finding time, distance, speed	3-1-2
Multiplication	3-1-1
Tan Drop \angle charts for	2-5-2
Vector solutions	3-1-3
Electrically heated flying suits	9-21-5
Emergencies and precautions	9-1-1, 9-21-6
Climate and health	9-21-1
Dangerous gases	9-9-1
Ditching	9-16-1
Effects of high altitude	9-4-1
Flak suits	9-10-1
Fire fighting	9-12-1
First aid in flight	9-1-1
First-aid kits	9-2-1
Life preserver vest	9-14-1
Life raft kits and discipline	9-17-1
One-man life raft	9-18-1
Oxygen emergencies	9-8-1
Oxygen equipment	9-5-1
Parachutes and parachute jumps	9-13-1
Physical fitness	9-3-1
Portable oxygen equipment	9-5-1
Pressure breathing	9-7-1
Signal devices	9-19-1
Swimming through fire	9-15-1
Vest type emergency kit	9-20-1
Vision at night	9-11-1
Emergency release (salvo)	7-4-2
Emerson nose turret (B-24)	7-10-1
Equations	2-5-1
Evasive action	8-5-3

F

Films and publications	1-7-1
Finding GS with E-6B computer	2-5-2
Fire, swimming through	9-15-1
Fire fighting	9-12-1
Fire-fighting equipment in airplanes	9-12-2

First aid for gas victims	9-9-2
First aid in flight	9-1-1
First-aid kits	9-2-1
Five-degree (5°) funnel	8-10-3
Fix, how to take, with radio compass	4-11-2
Fixed-angle bombing errors	2-3-6
Fixes, lines of position and	4-9-2
Flak	8-5-1
Barrage fire	8-5-2
Continuously pointed fire	8-5-1
Predicted concentration fire	8-5-1
Flak analysis and evasive action	8-5-1
Flak helmets	9-10-1
Flak suits	9-10-1
Fleas	9-21-3
Flies	9-21-3
Flight adjustments (autopilot)	5-4-1
Centering	5-4-1
Dashpot	5-4-2
Ratio	5-4-1
Sensitivity	5-4-1
Turn compensation	5-4-2
Turn control	5-4-3
Flux gate compass, gyro-stabilized	4-6-1
Flying suits, electrically heated	9-21-5
Food and water in tropics	9-21-3
Form 12C (Bombing flight record)	1-4-1
Formation bombing	8-6-1
Formation stick	5-7-1
Fractures	9-1-3
Free air temperature gage	4-1-1
Calibration of	4-1-1
Frostbite	9-1-4, 9-21-7
Fuzes	7-2-1, 7-3-1
Arming pin nose fuze	7-2-2
Arming vane nose fuze	7-2-2
Arming vane tail fuzes	7-2-1, 7-2-3
Chart	7-2-3
Installation	7-3-1
Precautions in handling	7-2-1

G

G-1 computer	3-4-1
How to use	3-4-1
True airspeed computations	3-4-1
Gases, dangerous	9-9-1
Exhaust gas	9-9-1
First aid for	9-9-2
Gasoline vapors	9-9-1
Hydraulic fluid vapors	9-9-2

Poison gases	9-9-2
Smoke	9-9-2
Gases, expansion of trapped	9-4-1
Groundspeed (GS)	2-1-1, 2-5-5
Gun turrets	7-10-1
Gyroscopes, bombsight	6-1-4
Gyro-stabilized flux gate compass	4-6-1
Gyro, vertical flight (autopilot)	5-1-2

H

Heatstroke	9-21-2
High altitude bombing	8-7-1
Bombing approach	8-7-1
Bombing run	8-7-2
Hints	8-7-2
Horizontal distance from Sight \angle (graph)	2-5-6
Hydraulic fluid vapors	9-9-2

I

Instrument calibration and navigation	4-1-1
Interphone procedure	1-6-2
Interrogation, briefing and	8-2-1

J

Jackbox switch	1-6-1
Junction box (autopilot)	5-1-4

K

Kits	
Bombardier's	1-3-1
First-aid, aeronautic	9-2-1
Life raft	9-17-2
Vest type emergency	9-20-1

L

Lice	9-21-3
Life preserver vest	9-14-1
Life raft kits and discipline	9-17-1
Life raft, one-man	9-18-1
Line of sight	2-1-2
Lines of position (LOP) and fixes	4-9-2
Logs	4-9-3, 4-10-1

DR	4-10-1
Pilotage	4-9-3

M

Machine gun, caliber .50	7-9-1
Magnetic compass	4-5-1
Compensating	4-5-1
Swinging	4-5-2
Malaria	9-21-3
Maneuvering targets	2-1-4, 8-11-1
Procedure	8-11-1
Speeds and rate of turns	8-11-2
Summary	8-11-3
Mean pressure altitude (MPA), how to find	3-3-3
Mean temperature, how to find	3-3-2
Medium altitude bombing	8-8-1
Minimum altitude bombing	8-9-1
Mil values of 1 rpm DS	2-5-3
Microphones	1-6-2
Mites	9-21-3
Morphine	9-1-2
Mosquitoes	9-21-2
Moving targets, bombing	2-1-4
M-series bombsight	6-1-1

N

Navigation, dead reckoning	4-10-1
Navigation, instrument calibration and	4-1-1
Navigation, pilotage	4-9-1
Navigation, radio, aids	4-11-1
Night pilotage	4-9-4
Night vision	9-11-1
Normal bomb release (train)	7-4-2
Numbers	1-6-4
Code	1-6-4
Phonetic	1-6-4

O

Off-course corrections	4-9-3
One-man life raft	9-18-1
One rpm DS, mil values of	2-5-3
Oxygen emergencies	9-8-1
Oxygen equipment	9-5-1
Continuous flow system	9-5-3
Demand system	9-5-1
Oxygen, five golden rules for	9-4-3

Oxygen for ditching	9-6-2
Oxygen, portable, equipment	9-6-1
Bailout bottles	9-6-2
How to use	9-6-1
Walk-around bottle	9-6-1
Oxygen supply, failure of	9-1-4
Oxygen want (anoxia)	9-4-1

P

Packet, first-aid, parachute	9-2-1
Parachute bombing	8-10-4
Parachutes and parachute jumps	9-13-1
Phonetic alphabet	1-6-4
Physical fitness	9-3-1
Pilotage logs	4-9-3
Pilotage navigation	4-9-1
Pilotage, night	4-9-4
Pilotage winds	4-9-4
Pitot-static system	4-2-1
Poison gases	9-9-2
Pressure altitude (PA)	3-3-2
Pressure altitude above target, how to find	3-3-2
Pressure breathing	9-7-1
Propellers, deaths caused by	9-12-1
Publications, films and	1-7-1

R

Radio compass	4-11-1
Radio navigation aids	4-11-1
Radio range beam legs, using	4-11-1
Radio telephone (R/T) procedure	1-6-1
Messages	1-6-4
Terms	1-6-3
Range angle	2-1-2
Range component of crosstrail (RCCT)	2-1-4
Equation for computing	2-1-4
Range problem, solution of	2-1-4
Remote control turret system (B-29)	7-10-2
Rotary inverter (autopilot)	5-1-4

S

Safeguarding classified material	1-5-1
Salt, use of, in warm climates	9-21-2
Servo units (autopilot)	5-1-4
Setting up course (bombsight)	6-1-2
Shock	9-1-2

Sickness, decompression	9-4-3
Sighting angle (Sight L)	2-1-2
Sighting angle, horizontal distance from	2-5-6
Signal devices	9-19-1
Body signals	9-19-3
Panel signals	9-19-4
Pyrotechnic pistols	9-19-1
Smoke grenades	9-19-2
Skin, care of, in tropics	9-21-4
Smoke	9-9-2
Smoke grenades	9-19-2
Snowblindness	9-21-8
Solution of course problem	2-1-3
Solution of range problem	2-1-4
Stabilizer (autopilot)	5-1-1
Staff bombardier, duties of	1-2-1
Sunstroke	9-21-2
Swimming through fire	9-15-1
Synchronous bombing errors	2-3-1

T

Tactical variations (European theater)	8-10-1
Bombing aids	8-10-3
Formations	8-10-2
Targets and enemy defenses	8-10-2
Weather	8-10-2
Tactical variations (Far Eastern theaters)	8-10-4
Bombing aid	8-10-6
Enemy defenses	8-10-5
Minimum altitude bombing	8-10-4
Night bombing	8-10-5
Parachute bombing	8-10-4
Types of missions (Weather)	8-10-5
Tan Drop \angle charts for E-6B computer	2-5-2
Tangents of angles	2-1-3
Target identification	8-3-1
AAF city plans	8-3-5
Aerial photographs	8-3-5
Aeronautical charts	8-3-2
Analysis and planning	8-3-5
Air objective folder	8-3-1
Camouflage	8-3-10
Checklist	8-3-8
Check points	8-3-6
Target charts and perspectives	8-3-2
Target chart and perspective symbols	8-3-4
Target folder, how to use	8-3-1
Target folder, how to prepare	8-3-8
Target folders, types of	8-3-1
Terrain print	8-3-5

Target pressure altitude (TPA)	3-3-2
How to compute	3-3-2
Target temperature, how to estimate	3-3-2
Technical order numbering system	1-7-1
Time-of-run computations	3-5-1
Using fast calculations	3-5-2
Using J-1 sighting angle computer	3-5-1
Using sighting angle equation	3-5-2
Using trail and error timing	3-5-2
Trail (T)	2-1-1
Trail angle (Trail L)	2-1-2
Train bombing	8-4-1
Trail deficiency, DS compensation for	2-5-3
Transportation of wounded	9-1-3
True airspeed (TAS)	2-1-1
True vertical	2-1-1
Turrets, gun	7-10-1
Turret system (B-29), remote control	7-10-2

U

Unconsciousness, near-unconsciousness	9-1-4
Unsatisfactory reports (UR's)	1-8-1

V

Vacuum DS for any bomb	2-2-2
Venereal disease	9-21-4
Vertical flight gyro (autopilot)	5-1-2
Vest, life preserver	9-14-1
Vest type emergency kit	9-20-1
Vision at night	9-11-1
Visual recognition	1-6-4

W

Walk-around bottle	9-6-1
Warm climate health	9-21-1
Water, food and, in tropics	9-21-3
Whole range (WR)	2-1-2
Whole range angle (WR L)	2-1-2
Wind	2-1-1, 3-2-2
Finding, with bombsight, AB computer	3-2-2
Setting known, on AB computer	3-2-2
Wound disinfectants	9-1-4

Y

Yellow fever	9-21-3
--------------	--------

